

harman/kardon

DPR1005

DPR2005

DIGITAL PATH AUDIO/VIDEO RECEIVER

SERVICE MANUAL



CONTENTS

NOTICES – PLEASE READ FIRST	2	BULLETIN HK2005-03	32
ELECTROSTATICALLY SENSITIVE DEVICES.....	3	TECH TIP HKTT2003-01	33
LEAKAGE TESTING.....	4	CIRCUIT DESCRIPTION	34
DPR1005 SPECIFICATIONS.....	5	D2 GR70/GR120 POWER MODULE	35
DPR2005 SPECIFICATIONS.....	6	DPR1005 MECHANICAL PARTS LIST	51
FRONT PANEL CONTROLS.....	7	DPR1005 ELECTRICAL PARTS LIST	52
REAR PANEL CONNECTIONS.....	10	DPR2005 MECHANICAL PARTS LIST	63
MAIN REMOTE CONTROL FUNCTIONS.....	13	DPR2005 ELECTRICAL PARTS LIST	64
INSTALLATION/CONNECTIONS.....	17	SMPS (Power Supply) Electrical Parts List	75
OPERATION.....	20	SEMICONDUCTOR DATA	79
TROUBLESHOOTING GUIDE.....	26	PCB DRAWINGS	103
PROCESSOR RESET.....	26	SCHEMATICS	113
UNIT EXPLODED VIEWS.....	27	WIRING DIAGRAM	126
EXPLODED VIEW PARTS LIST.....	29	PACKAGING	127
BLOCK DIAGRAM.....	31		

harman/kardon, Inc.
250 Crossways Park Dr.
Woodbury, New York 11797

Rev1 7/2005

IMPORTANT NOTICES

DPR1005 and 2005 that are under the two-year warranty period are considered "factory service only" in the United States. Please have Customers contact harman/kardon directly at (516) 255-4545 to obtain warranty service. This service manual is being made available for units that are no longer under warranty, and products that are serviced outside the U.S.

During testing, do not inject an audio signal frequency into the unit higher than 20kHz with no load. Peaking in the output filter can cause the output voltages to exceed the filter capacitor voltage rating in this design. Normal audio program material will not have enough energy to cause problems. Avoid test tones above 20kHz.

The following pages 8 - 27, reprinted from the DPR2005 owner's manual, are accurate for every feature and operation of both the DPR1005 and DPR2005 with the following exception: The only **feature** difference between the two models is located in the front accessory jacks.

On the 2005 the Front-panel **digital coaxial/optical** jacks may be used as either Inputs or Outputs.

Those same jacks on the 1005 are for Inputs only; therefore there is also a missing indicator light for this function. For an accurate explanation of these jacks, refer to the DPR1005 owner's manual.

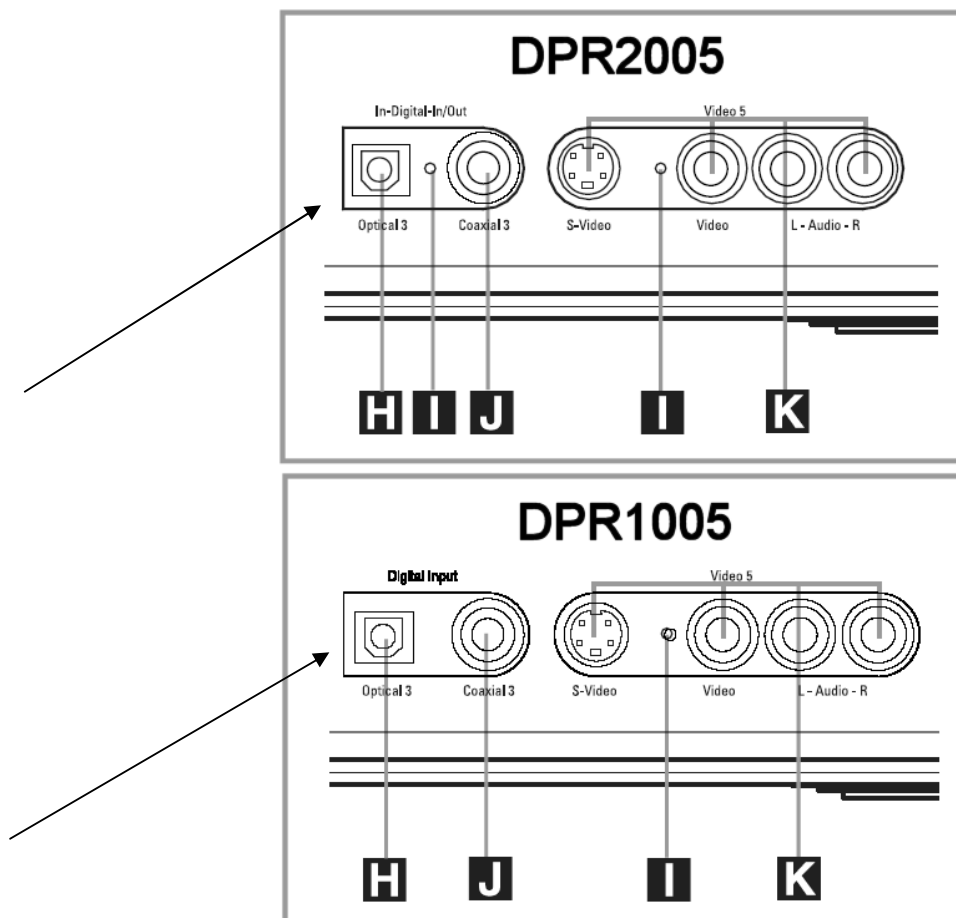

ELECTROSTATICALLY SENSITIVE (ES) DEVICES

Some semiconductor (solid state) devices can be damaged easily by static electricity. Such components commonly are called Electrostatically Sensitive (ES) Devices. Examples of typical ES devices are integrated circuits and some field effect transistors and semiconductor "chip" components.

The following techniques should be used to help reduce the incidence of component damage caused by static electricity.



1. Immediately before handling any semiconductor component or semiconductor-equipped assembly, drain off any electrostatic charge on your body by touching a known earth ground. Alternatively, obtain and wear a commercially available discharging wrist strap device, which should be removed for potential shock reasons prior to applying power to the unit under test.
2. After removing an electrical assembly equipped with ES devices, place the assembly on a conductive surface such as aluminum foil, to prevent electrostatic charge build-up or exposure of the assembly.
3. Use only a grounded-tip soldering iron to solder or unsolder ES devices.
4. Use only an anti-static solder removal device. Some solder removal devices not classified as "anti-static" can generate electrical charges sufficient to damage ES devices.
5. Do not use freon-propelled chemicals. These can generate electrical charge sufficient to damage ES devices.
6. Do not remove a replacement ES device from its protective package until immediately before you are ready to install it. (Most replacement ES devices are packaged with leads electrically shorted together by conductive foam, aluminum foil or comparable conductive material.)
7. Immediately before removing the protective material from the leads of a replacement ES device, touch the protective material to the chassis or circuit assembly into which the device will be installed.

CAUTION : Be sure no power is applied to the chassis or circuit, and observe all other safety precautions.

8. Minimize bodily motions when handling unpackaged replacement ES devices. (Otherwise harmless motion such as the brushing together of your clothes fabric or the lifting of your foot from a carpeted floor can generate static electricity sufficient to damage an ES devices.

PRODUCT SAFETY NOTICE

Each precaution in this manual should be followed during servicing.

Components identified with the IEC symbol  in the parts list are special significance to safety. When replacing a component identified with , use only the replacement parts designated, or parts with the same ratings or resistance, wattage, or voltage that are designated in the parts list in this manual. Leakage-current or resistance measurements must be made to determine that exposed parts are acceptably insulated from the supply circuit before returning the product to the customer.

LEAKAGE TEST(FOR SERVICE ENGINEERS IN THE U.S.A)

Before returning the unit to the user, perform the following safety checks :

1. Inspect all lead dress to make certain that leads are not pinched or that hardware is not lodged between the chassis and other metal parts in the unit.
2. Be sure that any protective devices such as nonmetallic control knobs, insulating fish-papers, cabinet backs, adjustment and compartment covers or shields, isolation resistor-capacity networks, mechanical insulators, etc. Which were removed for the servicing are properly re-installed.
3. Be sure that no shock hazard exists ; check for leakage current using Simpson Model 229 Leakage Tester, standard equipment item No. 21641, RCA Model WT540A or use alternate method as follows : Plug the power cord directly into a 120 volt AC receptacle (do not use an Isolation Transformer for this test). Using two clip leads, connect a

1500 ohms, 10watt Resistor paralleled by a 0.15uF capacitor, in series with all exposed metal cabinet parts and a known earth ground, such as a water pipe or conduit. Use a VTVM or VOM with 1000 ohms per volt, or higher sensitivity to measure the AC voltage drop across the resistor. (See diagram) Move the resistor connection to each exposed metal part having a return path to the chassis (antenna, metal cabinet, screw heads, knobs and control shafts, escutcheon, etc.) and measure the AC voltage drop across the resistor. (This test should be performed with the 0.35 volt RMS or more is excessive and indicates a potential shock hazard which must be corrected before returning the unit to the owner.

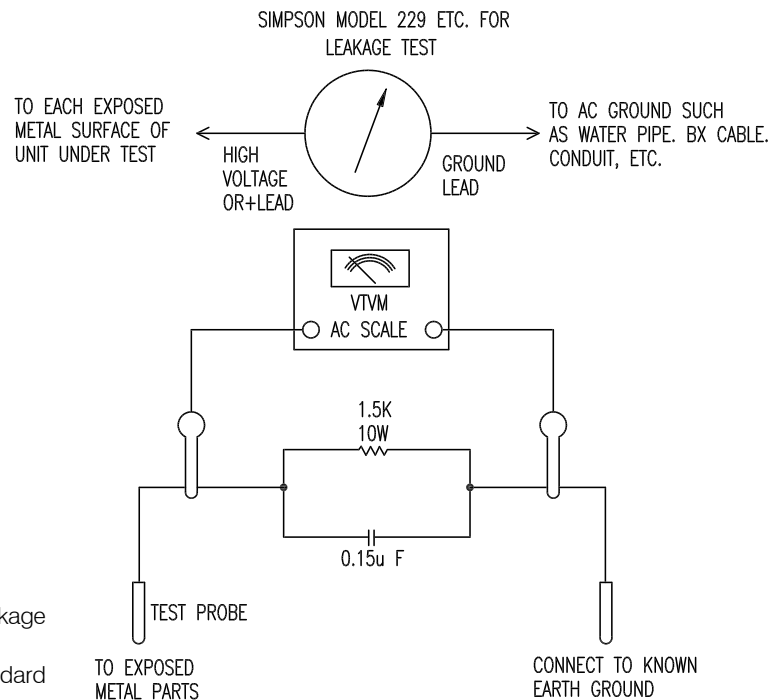

DPR 1005 TECHNICAL SPECIFICATIONS

Audio Section

Stereo Mode

Continuous Average Power (FTC)

70 Watts per channel, 20Hz–20kHz,
@ <0.15% THD, both channels driven into 8 ohms

Seven-Channel Surround Modes

Power per Individual Channel

Front L&R channels:
70 Watts per channel
@ <0.15% THD, 20Hz–20kHz into 8 ohms

Center channel:
70 Watts @ <0.15% THD, 20Hz–20kHz into 8 ohms

Surround (L & R Side, L & R back) channels:
70 Watts per channel
@ <0.15% THD, 20Hz–20kHz into 8 ohms

Input Sensitivity/Impedance

Linear (High-Level) 200mV/47k ohms

Signal-to-Noise Ratio (IHF-A) 97dB

Surround System Adjacent Channel Separation

Pro Logic I/II/Ix 40dB

Dolby Digital 55dB

DTS 55dB

Transient Intermodulation

Distortion (TIM) Unmeasurable

FM Tuner Section

Frequency Range 87.5–108.0MHz

Usable Sensitivity IHF 1.3µV/13.2dBf

Signal-to-Noise Ratio Mono/Stereo 70/68dB

Distortion Mono/Stereo 0.2/0.3%

Stereo Separation 40dB @ 1kHz

Selectivity ±400kHz, 70dB

Image Rejection 80dB

IF Rejection 90dB

AM Tuner Section

Frequency Range 520–1720kHz

Signal-to-Noise Ratio 45dB

Usable Sensitivity Loop 500µV

Distortion 1kHz, 50% Mod 0.8%

Selectivity ±10kHz, 30dB

Video Section

Television Format NTSC

Input Level/Impedance 1Vp-p/75 ohms

Output Level/Impedance 1Vp-p/75 ohms

Video Frequency Response
(Composite and S-Video) 10Hz–8MHz (–3dB)

Video Frequency Response
(Component Video) 10Hz–50MHz (–3dB)

General

Power Requirement AC 120V/60Hz

Power Consumption Standby: 8.9W

Idle: 52W

Max: 760W

(7 channels driven)

Dimensions

	Product	Shipping
Width	17.3 inches (440mm)	20.1 inches (510mm)
Height	4.5 inches (114mm)	10 inches (254mm)
Depth	18.8 inches (476mm)	22.2 inches (565mm)

Weight 23.1 lb (10.5kg) 47 lb (21.4kg)

Depth measurement includes knobs, buttons and terminal connections.

Height measurement includes feet and chassis.

All features and specifications are subject to change without notice.

Harman Kardon, Power for the Digital Revolution and Logic 7 are registered trademarks of Harman International Industries, Incorporated.

IIIIEzSet is a trademark of Harman International Industries, Incorporated (patent no. 5,386,478).

*Trademarks of Dolby Laboratories.

DTS, DTS Surround, DTS-ES and DTS Neo:6 are registered trademarks of Digital Theater Systems, Inc.

VMAx is a registered trademark of Harman International Industries, Incorporated, and is an implementation of Cooper Bauck Transaural Stereo under patent license.

HDCD system manufactured under license from Pacific Microsonics, Inc. This product is covered by one or more of the following: in the USA: 5,479,168; 5,638,074; 5,640,161; 5,808,574; 5,838,274; 5,854,600; 5,864,311; 5,872,531; and in Australia: 669114. Other patents pending.

A-BUS and A-BUS Ready are registered trademarks of Leisure Tech Electronics Pty Ltd Australia.

TiVo is a registered trademark of TiVo, Inc.

Replay TV is a registered trademark of Digital Networks North America, Inc.

250 Crossways Park Drive, Woodbury, New York 11797
www.harmankardon.com
© 2004 Harman International Industries, Incorporated
Part No. ZKD0301HA00-9

DPR 2005 TECHNICAL SPECIFICATIONS

Audio Section

Stereo Mode

Continuous Average Power (FTC)

120 Watts per channel, 20Hz–20kHz,
@ <0.15% THD, both channels driven into 8 ohms

Seven-Channel Surround Modes

Power per Individual Channel

Front L&R channels:

120 Watts per channel
@ <0.15% THD, 20Hz–20kHz into 8 ohms

Center channel:

120 Watts @ <0.15% THD, 20Hz–20kHz into 8 ohms

Surround (L & R Side, L & R back) channels:

120 Watts per channel

@ <0.15% THD, 20Hz–20kHz into 8 ohms

Input Sensitivity/Impedance

Linear (High-Level) 200mV/47k ohms

Signal-to-Noise Ratio (IHF-A) 97dB

Surround System Adjacent Channel Separation

Pro Logic I/II/Ix 40dB

Dolby Digital 55dB

DTS 55dB

Transient Intermodulation

Distortion (TIM) Unmeasurable

FM Tuner Section

Frequency Range 87.5–108.0MHz

Usable Sensitivity IHF 1.3µV/13.2dBf

Signal-to-Noise Ratio Mono/Stereo 70/68dB

Distortion Mono/Stereo 0.2/0.3%

Stereo Separation 40dB @ 1kHz

Selectivity ±400kHz, 70dB

Image Rejection 80dB

IF Rejection 90dB

AM Tuner Section

Frequency Range 520–1720kHz

Signal-to-Noise Ratio 45dB

Usable Sensitivity Loop 500µV

Distortion 1kHz, 50% Mod 0.8%

Selectivity ±10kHz, 30dB

Video Section

Television Format NTSC

Input Level/Impedance 1Vp-p/75 ohms

Output Level/Impedance 1Vp-p/75 ohms

Video Frequency Response
(Composite and S-Video) 10Hz–8MHz (–3dB)

Video Frequency Response
(Component Video) 10Hz–50MHz (–3dB)

General

Power Requirement AC 120V/60Hz

Power Consumption Standby: 8.9W

Idle: 58W

Max: 1073W

(7 channels driven)

Dimensions

	Product	Shipping
Width	17.3 inches (440mm)	20.1 inches (510mm)
Height	4.5 inches (114mm)	10 inches (254mm)
Depth	18.8 inches (476mm)	22.2 inches (565mm)

Weight 23.1 lb (10.5kg) 47 lb (21.4kg)

Depth measurement includes knobs, buttons and terminal connections.

Height measurement includes feet and chassis.

All features and specifications are subject to change without notice.

Harman Kardon, Power for the Digital Revolution and Logic 7 are registered trademarks of Harman International Industries, Incorporated.

IIIIEzSet is a trademark of Harman International Industries, Incorporated (patent no. 5,386,478).

*Trademarks of Dolby Laboratories.

DTS, DTS Surround, DTS-ES and DTS Neo:6 are registered trademarks of Digital Theater Systems, Inc.

VMAx is a registered trademark of Harman International Industries, Incorporated, and is an implementation of Cooper Bauck Transaural Stereo under patent license.

HDCD system manufactured under license from Pacific Microsonics, Inc. This product is covered by one or more of the following: in the USA: 5,479,168; 5,638,074; 5,640,161; 5,808,574; 5,838,274; 5,854,600; 5,864,311; 5,872,531; and in Australia: 669114. Other patents pending.

A-BUS and A-BUS Ready are registered trademarks of Leisure Tech Electronics Pty Ltd Australia.

TiVo is a registered trademark of TiVo, Inc.

Replay TV is a registered trademark of Digital Networks North America, Inc.

FRONT-PANEL CONTROLS

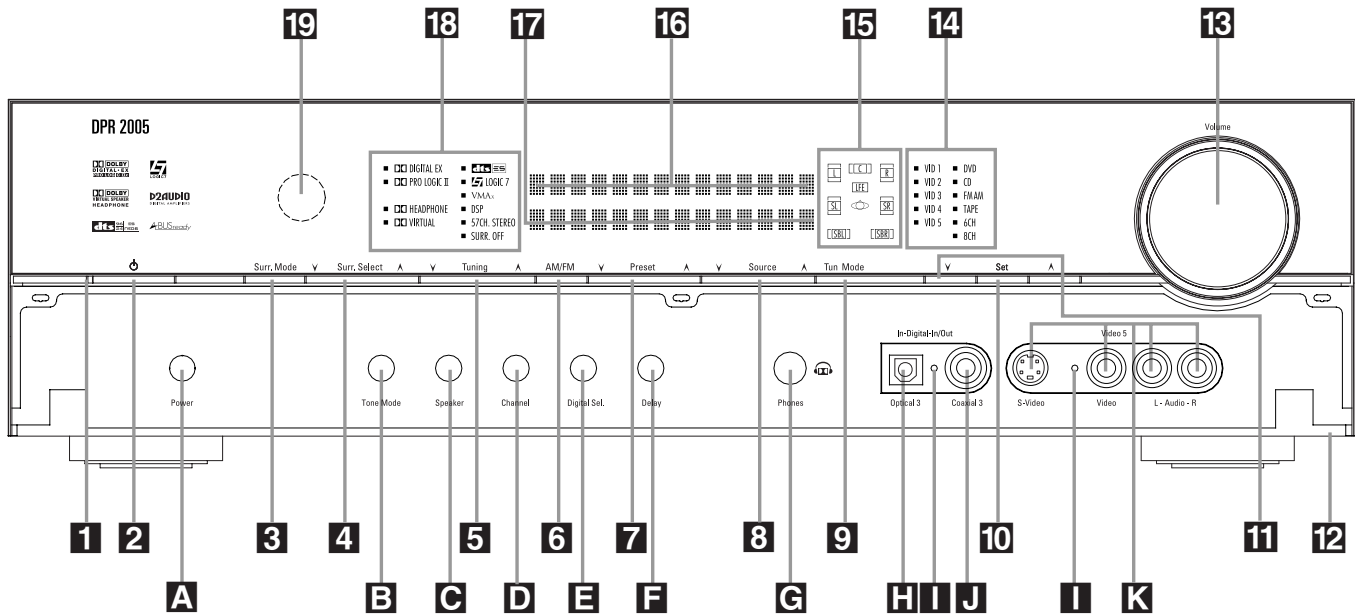

NOTE: To make it easier to follow the instructions that refer to this illustration, a larger copy may be downloaded from the Product Support section for this product at www.harman-kardon.com.

The following controls and indicators are available on the DPR 2005's front panel:

- | | | |
|---------------------------------------|------------------------------------|--------------------------------------------|
| 1 Standby/On Indicator | 8 Input Source Selector | 15 Speaker/Channel Input Indicators |
| 2 Standby/On Button | 9 Tuning Mode Selector | 16 Upper Display Line |
| 3 Surround Mode Group Selector | 10 Set Button | 17 Lower Display Line |
| 4 Surround Mode Selector | 11 ▼/▲ Buttons | 18 Surround Mode Indicators |
| 5 Tuning Selector | 12 Front-Panel Control Door | 19 Remote Sensor Window |
| 6 Tuner Band Selector | 13 Volume Control | |
| 7 Preset Station Selector | 14 Input Indicators | |

The following controls and jacks are located behind the front-panel door. To open the door, press the center of the door and gently swing it down towards you.

- | | | |
|----------------------------------|----------------------------------|------------------------------------|
| A Main Power Switch | E Digital Input Selector | I Input/Output Indicators |
| B Tone Mode Button | F Delay Adjust Selector | J Coaxial 3 Digital Jack |
| C Speaker Selector Button | G Headphone Jack | K Video 5 Audio/Video Jacks |
| D Channel Adjust Selector | H Optical 3 Digital Input | |

1 Standby/On Indicator: This indicator is amber when the DPR is in the Standby mode to signal that the unit is connected to an AC power source and is ready to be put into operation. When the unit is in use, the indicator turns blue.

2 Standby/On Button: When the **Main Power Switch A** is "ON," press this button to turn on the DPR 2005; press it again to turn the unit off.

3 Surround Mode Group Selector: Press this button to select the top-level group of surround modes. Each press of the button will select one of the surround mode categories. Once the button is pressed so that the name of the desired surround mode category appears in the on-screen display and in the **Lower Display Line 17**, press the **Surround Mode Selector 4** to cycle through the individual modes available. For example, press this button to select Dolby

modes, and then press the **Surround Mode Selector 4** to choose from the various mode options.

4 Surround Mode Selector: Press this button to select from among the available surround mode options for the surround mode category selected. The specific modes will vary based on the number of speakers available, the surround mode category and whether the input source is digital or analog. For example, press the **Surround Mode Group Selector 3**

FRONT - PANEL CONTROLS

to select a category such as Dolby or Logic 7, and then press this button to see the specific mode choices that are available. For more information on mode selection, see page 32.

5 Tuning Selector: Press the left side of the button to tune lower-frequency stations and the right side of the button to tune higher-frequency stations. When the tuner is in the **MANUAL / MONO** mode, each tap of the Selector will increase or decrease the frequency by one increment. When the tuner receives a strong-enough signal for adequate reception, **MANUAL TUNED** will appear in the **Lower Display Line 17** and in the on-screen display. When the tuner is in the **AUTO / STEREO** mode, press the button once, and the tuner will scan for a station with acceptable signal strength. When the next higher or lower frequency station with a strong-enough signal is tuned, the frequency scan will stop and the **Lower Display Line 17** and the on-screen display will indicate **AUTO TUNED**. When an FM Stereo station is tuned, the display will read **AUTO ST TUNED**. See page 35 for more information on using the tuner.

6 Tuner Band Selector: Pressing this button will automatically switch the DPR 2005 to the Tuner mode. Pressing it again will switch between the AM and FM frequency bands. (See page 35 for more information on the tuner.)

7 Preset Stations Selector: Press this button to scroll up or down through the list of stations that have been entered into the preset memory. (See page 35 for more information on tuner programming.)

8 Input Source Selector: Press this button to change the input by scrolling up or down through the list of input sources.

9 Tuning Mode Selector: Press this button to select Auto or Manual tuning. When the button is pressed so that **AUTO / STEREO** appears in the **Upper Display Line 16**, the tuner will search for the next station with an acceptable signal when the **Tuning Selector 5 23 E** is pressed. When the button is pressed so that **MANUAL / MONO** appears in the **Upper Display Line 16**, each press of the **Tuning Selector 5 23 E** will increase the frequency. (See page 35 for more information on using the tuner.) This button may also be used to switch between Stereo and Mono modes for FM radio reception. When weak reception is encountered, select the Manual/Mono tuning mode. Press and hold again to switch back to

Stereo mode. (See page 35 for more information on using the tuner.)

10 Set Button: When making system configuration changes using the front-panel controls, press this button to enter a setting into the unit's memory.

11 ▼/▲ Buttons: When making system configuration changes using the front-panel controls, press these buttons to scroll through the available choices for the option being adjusted.

12 Front-Panel Control Door: To open the door so that the front-panel jacks and controls behind this door may be accessed, press the center of the door and gently swing it down towards you.

13 Volume Control: Turn this knob clockwise to increase the volume, counterclockwise to decrease the volume. If the DPR 2005 is muted, adjusting the volume control will automatically release the unit from the silenced condition.

14 Input Indicators: One of these indicators will light to identify the currently selected input. Note that the entire list will light briefly each time the unit is turned on as a test.

15 Speaker/Channel Input Indicators: These indicators are multipurpose, indicating both the speaker type selected for each channel and the incoming data-signal configuration. The left, center, right, right surround and left surround speaker indicators light as a single outline around the speaker position indicator when a "small" speaker is selected and as a larger icon with three connected boxes when "large" speakers are selected. When only the speaker position letters appear, no speaker has been assigned that position. (See page 24 for more information on configuring speakers.) The letters inside each box also indicate the active input channels. For standard analog inputs, only the L and R will light, indicating a stereo input. For a digital source, the indicators will light to display the channels being received at the digital input. When the letters flash, the digital input has been interrupted and an **UNLOCK** message may appear in the **Lower Display Line 17**. (See page 34 for more information on the Channel Indicators.)

16 Upper Display Line: Depending on the unit's status, a variety of messages will appear here. In normal operation, this line will show the current input source and identify whether an analog or digital input is in use. When the tuner is selected as the input, this line will identify the station as AM or FM and show the

frequency and preset number, if any.

17 Lower Display Line: Depending on the unit's status, a variety of messages will appear here. In normal operation, the current surround mode will appear on this line.

18 Surround Mode Indicators: One of these indicators will light to show the surround mode in use. Depending on the specific combination of input sources and surround mode selected, more than one indicator may light. (See page 33 for more information.)

19 Remote Sensor Window: The sensor behind this window receives infrared signals from the remote control. Aim the remote at this area and do not block or cover it unless an external remote sensor is installed.

FRONT - PANEL CONTROLS

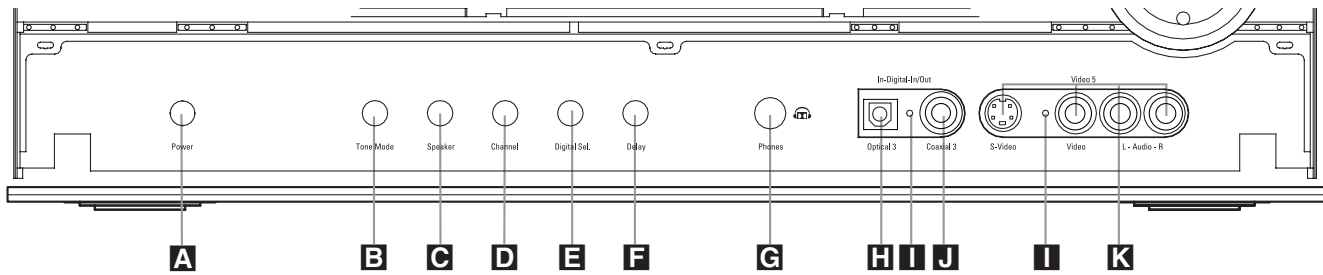

NOTE: To make it easier to follow the instructions that refer to this illustration, a larger copy may be downloaded from the Product Support section for this product at www.harmankardon.com.

The following controls and jacks are located behind the front-panel door. To open the door, press the center of the door and gently swing it down towards you.

- | | | |
|----------------------------------|----------------------------------|------------------------------------|
| A Main Power Switch | E Digital Input Selector | I Input/Output Indicators |
| B Tone Mode Button | F Delay Adjust Selector | J Coaxial 3 Digital Jack |
| C Speaker Selector Button | G Headphone Jack | K Video 5 Audio/Video Jacks |
| D Channel Adjust Selector | H Optical 3 Digital Input | |

A Main Power Switch: Press this switch to apply power to the DPR 2005. When the switch is pressed in, the unit is placed in a Standby mode, as indicated by the **Standby/On Indicator 11** turning amber. The switch **MUST** be pressed in to operate the unit. To turn the unit off and prevent the use of the remote control, this switch should be pressed until it pops out from the front panel so that the word "OFF" may be read at the top of the switch.

NOTE: This switch is normally left in the "ON" position.

B Tone Mode Button: This button controls the tone mode settings, enabling adjustment of the bass and treble boost/cut. You may also use it to take the tone controls out of the signal path completely for "flat" response. The first press of the button displays a **TONE MODE** message in the **Lower Display Line 17** and in the on-screen display. To take the controls out of the signal path, press either of the **▼/▲ Buttons 11** until the display reads **TONE OUT**. To change the bass or treble settings, press the button again until the desired option appears in the **Lower Display Line 17** and in the on-screen display and then press either of the **◀▶ Buttons 11** to enter the desired boost or cut setting. See page 30 for more information on the tone controls.

C Speaker Selector Button: Press this button to begin the process of configuring the DPR 2005 for the type of speakers it is being used with. For complete information on configuring the speaker settings, see page 24.

D Channel Adjust Selector: Press the button to begin the process of adjusting the channel level outputs using the source currently playing through your DPR. For complete information on adjusting the channel output level, see page 36.

E Digital Input Selector: Press this button to begin the process of selecting a digital source for use with the currently selected input. Once the button has been pressed, use the **▼/▲ Buttons 11** to choose the desired input and then press the **Set Button 10** to enter the setting into the unit's memory. See page 31 for more information on digital audio.

F Delay Adjust Selector: Press this button to begin the process of adjusting the delay settings for Dolby surround modes. See page 26 for more information on delay adjustments.

G Headphone Jack: This jack may be used to listen to the DPR 2005's output through a pair of headphones. Be certain that the headphones have a standard 1/4" stereo phone plug, or that you use an adapter, as needed, to convert the plug on your headphones to the 1/4" jack used on the AVR. When the headphone jack is in use, the main room speakers will automatically be turned off and the unit will output a standard stereo signal. You may also use one of the Dolby Headphone modes for an enhanced listening experience. For more information on headphone listening, see page 31.

H Optical 3 Digital Input: Connect the optical digital output of an audio or video product to this jack.

I Input/Output Status Indicators: These LED indicators will normally light green to show that the front-panel **Coaxial 3 Digital Jack J** and **Video 5 Input/Output Jacks K** are operating as inputs. When these jacks are configured for use as an output, the appropriate indicator will turn red to show that the jack may be used as an output for recording. (See page 35 for more information on configuring the front-panel jacks as outputs, rather than inputs.)

J Coaxial 3 Digital Jack: Connect the coaxial digital input or output for a digital audio product such as a portable audio player or video game to this jack. The jack is normally an input, but may be switched to an output for recording using the menu system. See page 35 for more information.

K Video 5 Input/Output Jacks: These audio/video jacks may be used as either an input or output for temporary connection to video games or portable audio/video products such as camcorders and portable audio players. (See page 35 for more information on switching these jacks between an input and output.)

REAR-PANEL CONNECTIONS

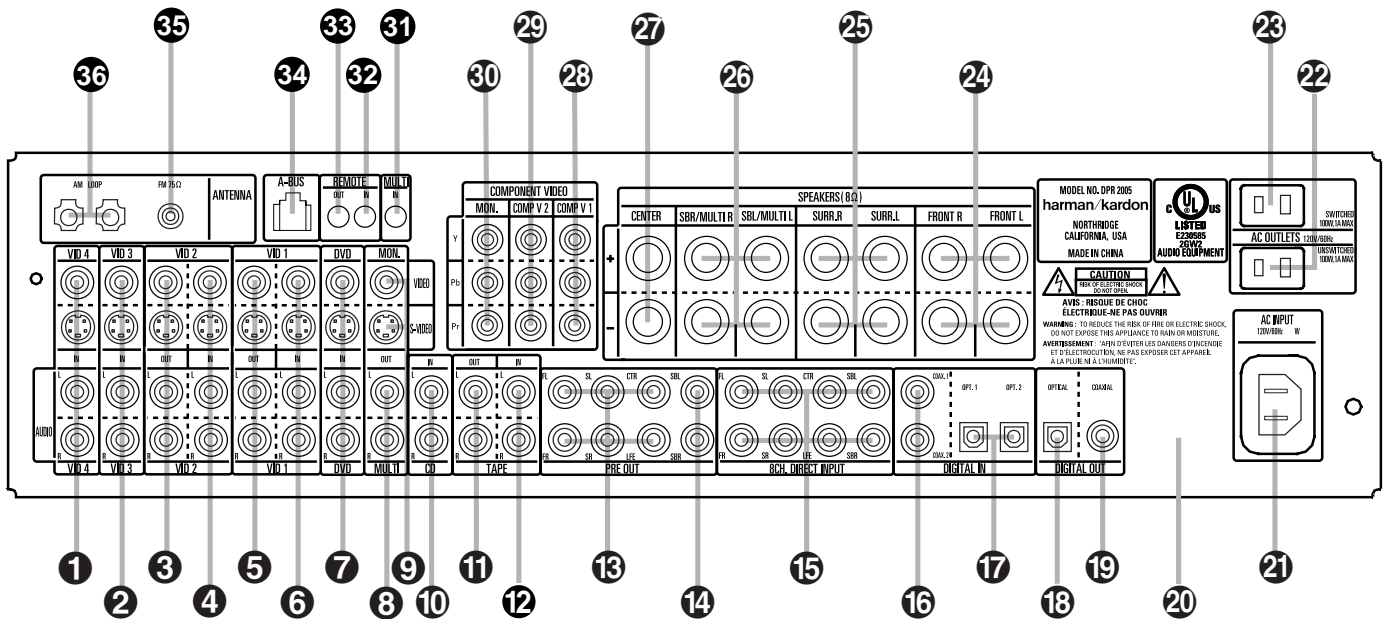

NOTE: To make it easier to follow the instructions that refer to this illustration, a larger copy may be downloaded from the Product Support section for this product at www.harmankardon.com.

- | | | |
|-------------------------------------------------------------------------------------------------------------------------------------------------------------------------------------------------------------------------------------------------------------------------------------------------------------------------------------------------------------------------|-------------------------------------------------------------------------------------------------------------------------------------------------------------------------------------------------------------------------------------------------------------------------------------------------------------------------------------------------------------------------------------------------------------------------------------------------------------------|-----------------------------------------------------------------------------------------------------------------------------------------------------------------------------------------------------------------------------------------------------------------------------------------------------------------------------------------------------------------------------------------------------------------------------------------------------------------------------|
| <ul style="list-style-type: none"> 1 Video 4 Inputs 2 Video 3 Inputs 3 Video 2 Outputs 4 Video 2 Inputs 5 Video 1 Outputs 6 Video 1 Inputs 7 DVD Inputs 8 Multiroom Audio Outputs 9 Video Monitor Outputs 10 CD Inputs 11 Tape Outputs 12 Tape Inputs | <ul style="list-style-type: none"> 13 Preamp Outputs 14 Subwoofer Output 15 8-Channel Direct Inputs 16 Coaxial Digital Audio Inputs 17 Optical Digital Audio Inputs 18 Optical Digital Audio Output 19 Coaxial Digital Audio Output 20 RS-232 Port 21 AC Power Cord Jack 22 Unswitched AC Outlet 23 Switched AC Outlet 24 Front Speaker Outputs | <ul style="list-style-type: none"> 25 Surround Speaker Outputs 26 Surround Back/Multiroom Speaker Outputs 27 Center Speaker Outputs 28 Component Video 1 Inputs 29 Component Video 2 Inputs 30 Component Video Monitor Outputs 31 Multiroom IR Input 32 Remote IR Input 33 Remote IR Output 34 A-BUS Connector 35 FM Antenna Jack 36 AM Antenna Terminals |
|-------------------------------------------------------------------------------------------------------------------------------------------------------------------------------------------------------------------------------------------------------------------------------------------------------------------------------------------------------------------------|-------------------------------------------------------------------------------------------------------------------------------------------------------------------------------------------------------------------------------------------------------------------------------------------------------------------------------------------------------------------------------------------------------------------------------------------------------------------|-----------------------------------------------------------------------------------------------------------------------------------------------------------------------------------------------------------------------------------------------------------------------------------------------------------------------------------------------------------------------------------------------------------------------------------------------------------------------------|

<p>NOTE: To assist in making the correct connections for multichannel input, output and speaker connections, all connection jacks and terminals are color-coded in conformance with the CEA standards as follows:</p>	Front Left:	White	Subwoofer:	Purple
	Front Right:	Red	Digital Audio:	Orange
	Center:	Green	Composite Video:	Yellow
	Surround Left:	Blue	Component Video "Y":	Green
	Surround Right:	Gray	Component Video "Pr":	Red
	Surround Back Left:	Brown	Component Video "Pb":	Blue
	Surround Back Right:	Tan		

REAR-PANEL CONNECTIONS

1 Video 4 Inputs: Connect the left/right analog audio and composite or S-Video jacks of a video device to these jacks. The DPR 2005's remote control has a satellite receiver as the default for this input, but you may connect any video source such as a VCR, HDTV receiver, personal video recorder, or other device to these inputs. Note that if the source device offers either digital audio or component video capability, those connections must be made separately, and the DPR 2005 configured accordingly. (See page 20 for more information on configuring an input for various source options.)

2 Video 3 Inputs: Connect the left/right analog audio and composite or S-Video jacks of a video device to these jacks. The DPR 2005's remote control has a cable set-top as the default for this input, but you may connect any video source such as a VCR, HDTV or satellite receiver, personal video recorder, or other device to these inputs. Note that if the source device offers either digital audio or component video capability, those connections must be made separately, and the DPR 2005 configured accordingly. (See page 20 for more information on configuring an input for various source options.)

3 Video 2 Outputs: Connect the left/right analog audio and composite or S-Video RECORD/IN jacks of a video recording device such as a VCR, DVD-Recorder or personal video recorder to these jacks.

4 Video 2 Inputs: Connect the left/right analog audio and composite or S-Video PLAY/OUT jacks of a video recording device such as a VCR, DVD-Recorder or personal video recorder to these jacks. The DPR 2005's remote control has a "TV" as the default for this input, but you may connect any video source such as a VCR, HDTV or cable set-top box, personal video recorder, or other device to these inputs. Note that if the source device offers either digital audio or component video capability, those connections must be made separately, and the DPR 2005 configured accordingly. (See page 20 for more information on configuring an input for various source options.)

5 Video 1 Outputs: Connect the left/right analog audio and composite or S-Video RECORD/IN jacks of a video recording device such as a VCR, DVD-Recorder or personal video recorder to these jacks.

6 Video 1 Inputs: Connect the left/right analog audio and composite or S-Video PLAY/OUT jacks of a video recording device such as a VCR, DVD-Recorder or personal video recorder to these jacks.

The DPR 2005's remote control has a VCR as the default for this input, but you may connect any video source such as a VCR, HDTV or cable set-top box, personal video recorder, or other device to these inputs. Note that if the source device offers either digital audio or component video capability, those connections must be made separately, and the DPR 2005 configured accordingly. (See page 20 for more information on configuring an input for various source options.)

7 DVD Inputs: Connect the left/right analog audio and composite or S-Video jacks of a DVD player or other video source to these jacks. When digital audio and/or component video outputs are used with a DVD player and the DPR 2005, the default connection points are the **Coaxial 1 Digital Audio Input 16** and the **Component Video 1 Inputs 28**. If other jacks are used to connect a DVD player, the DPR may be reconfigured to accommodate the hookup by using the **IN/OUT SETUP** menu as shown on page 21.

8 Video Monitor Outputs: Connect these jacks to the composite or S-Video input of a TV monitor or video projector to view the on-screen menus and the output of any standard video source selected by the receiver's video switcher. Note that if both standard composite and S-Video sources are used, you must make connections from both Video Monitor Output jacks to your video display. In addition, if component video sources are used, you must also connect the **Component Video Outputs 30** to the video display.

9 Multiroom Outputs: Connect these jacks to the optional external audio power amplifier and video distribution system that delivers the source selected for multizone distribution.

10 CD Audio Inputs: Connect these jacks to the left/right analog audio output of a compact disc player or CD changer or other audio source.

11 Tape Outputs: Connect these jacks to the Record/Input jacks of an audio recorder.

1 Tape Inputs: Connect these jacks to the Play/Out jacks of an audio recorder.

13 Preamp Outputs: Connect these jacks to an optional, external power amplifier for applications where higher power is desired.

14 Subwoofer Output: Connect this jack to the line-level input of a powered subwoofer. If an external subwoofer amplifier is used, connect this jack to the subwoofer amplifier input.

15 8-Channel Direct Inputs: These jacks are used for connection to source devices such as DVD-Audio or SACD players with discrete analog outputs. Depending on the source device in use, all eight jacks may be used, though in many cases only connections to the front left/right, center, surround left/right and LFE (subwoofer input) jacks will be used for standard 5.1 audio signals.

16 Coaxial Digital Audio Inputs: Connect the coax digital output from a DVD player, HDTV receiver, the S/P-DIF output of a compatible computer sound card playing MP3 files or streams, LD player or CD player to these jacks. The signal may be a Dolby Digital signal, DTS signal or a standard PCM digital source. Do not connect the RF digital output of an LD player to these jacks.

17 Optical Digital Audio Inputs: Connect the optical digital output from a DVD player, HDTV receiver, the S/P-DIF output of a compatible computer sound card playing MP3 files or streams, LD player or CD player to these jacks. The signal may be a Dolby Digital signal, a DTS signal or a standard PCM digital source.

18 Optical Digital Audio Output: Connect this jack to the optical digital input connector on a CD-R/RW, MiniDisc or other compatible digital recorder.

19 Coaxial Digital Audio Output: Connect this jack to the coaxial digital input of a CD-R/RW, MiniDisc or other compatible digital recorder.

20 RS-232 Port: This jack may be used to control the DPR 2005 over a bi-directional RS-232 serial control link to a compatible computer or programmable remote control system. Due to the complexity of programming RS-232 commands we strongly recommend that connections to this port for control purposes be made by a trained and qualified technician. This jack may also link to a compatible computer to upgrade the software and operating system of the DPR 2005 when appropriate upgrades are available.

21 AC Power Cord Jack: Connect the AC power cord to this jack when the installation is complete. To ensure safe operation, use only the power cord supplied with the unit. If a replacement is required, it must be of the same type and capacity.

22 Unswitched AC Outlet: This outlet may be used to power any AC device. The power will remain on at this outlet regardless of whether the DPR 2005 is on or off.

REAR-PANEL CONNECTIONS

23 Switched AC Outlet: These outlets may be used to power any device you wish to have turned on when the DPR 2005 is turned on with the **Standby/On Switch 1**.

NOTE: The total power consumption of all devices connected to the rear panel AC outlets should not exceed 100 watts.

24 Front Speaker Outputs: Connect these outputs to the matching + or – terminals on your left and right speakers. When making speaker connections always make certain to maintain correct polarity by connecting the color-coded (white for front left and red for front right) (+) terminals on the DPR 2005 to the red (+) terminals on the speakers and the black (–) terminals on the DPR 2005 to the black (–) terminals on the speakers. See page 16 for more information on speaker polarity.

25 Surround Speaker Outputs: Connect these outputs to the matching + and – terminals on your surround channel speakers. In conformance with the CEA color-code specification, the blue terminal is the positive, or “+” terminal that should be connected to the red (+) terminal on the Surround Left speaker with older color-coding, while the gray terminal should be connected to the red (+) terminal on the Surround Right speaker with the older color-coding. Connect the black (–) terminal on the DPR to the matching black negative (–) terminals for each surround speaker. (See page 16 for more information on speaker polarity.)

26 Surround Back/Multiroom Speaker Outputs: These speaker terminals are normally used to power the surround back left/surround back right speakers in a 7.1 channel system. However, they may also be used to power the speakers in a second zone, which will receive the output selected for a multiroom system. To change the output fed to these terminals from the default of the Surround Back speakers to the Multiroom Output, you must change a setting in the **MULTI-ROOM SETUP** menu of the OSD system. See page 39 for more information on configuring this speaker output. In normal surround system use, the brown and black terminals are the surround back left channel positive (+) and negative (–) connections and the tan and black terminals are the surround back right positive (+) and negative (–) terminals. For multiroom use, connect the brown and black SBL terminals to the red and black connections on the left remote zone speaker and connect the tan and black SBR terminals to the red and black terminals on the right remote zone speaker.

27 Center Speaker Outputs: Connect these outputs to the matching + and – terminals on your center channel speaker. In conformance with the CEA color-code specification, the green terminal is the positive, or “+” terminal that should be connected to the red (+) terminal on speakers with the older color-coding. Connect the black (–) terminal on the DPR to the black negative (–) terminal on your speaker. (See page 16 for more information on speaker polarity.)

28 Component Video 1 Inputs: These inputs may be used with any video source device equipped with analog Y/Pr/Pb or RGB component video outputs. The factory default is for these jacks to be linked to the DVD input, but you may change the setting at any time through the **IN/OUT SETUP** menu. See page 21 for more information on configuring the component video inputs.

29 Component Video 2 Inputs: These inputs may be used with any video source device equipped with analog Y/Pr/Pb or RGB component video outputs. The factory default is for these jacks to be linked to the Video 2 input, but you may change the setting at any time through the **IN/OUT SETUP** menu. See page 21 for more information on configuring the component video inputs.

30 Component Video Monitor Outputs: Connect these outputs to the component video inputs of a video projector or monitor. When a source connected to one of the **Component Video Inputs 28/29** is selected the signal will be sent to these jacks.

31 Multiroom IR Input: Connect the output of an IR sensor in a remote room to this jack to operate the DPR 2005's multiroom control system.

32 Remote IR Input: If the DPR 2005's front-panel IR sensor is blocked due to cabinet doors or other obstructions, an external IR sensor may be used. Connect the output of the sensor to this jack.

33 Remote IR Output: This connection permits the IR sensor in the receiver to serve other remote controlled devices. Connect this jack to the “IR IN” jack on Harman Kardon (or other compatible) equipment.

34 A-BUS Connector: Connect this jack to an optional A-BUS®-certified remote room keypad or amplifier to extend the multiroom capabilities of your DPR 2005. See page 39 for more information on A-BUS.

35 FM Antenna: Connect the supplied indoor or an optional external FM antenna to this terminal.

36 AM Antenna: Connect the AM loop antenna supplied with the receiver to these terminals. If an external AM antenna is used, make connections to the **AM** and **GND** terminals in accordance with the instructions supplied with the antenna.

MAIN REMOTE CONTROL FUNCTIONS

- 1 Power Off Button
- 2 Power On Button
- 3 LCD Information Display
- 4 Input Selectors
- 5 AVR Selector
- 6 Test Button
- 7 DSP Surround Mode Selector
- 8 Logic 7 Mode Select Button
- 9 Direct Button
- 10 Clear Button
- 11 Numeric Keys
- 12 Tuning Mode Button
- 13 Dim Button
- 14 Channel Select Button
- 15 Navigation Button
- 16 Digital Select Button
- 17 Set Button
- 18 Volume Up/Down Buttons
- 19 Transport Fast-Play/Scan Buttons
- 20 Main Transport Controls
- 21 Track Skip Up/Down Buttons
- 22 Preset Up/Down Button
- 23 Tuning Up/Down Button
- 24 Disc Skip Button
- 25 Program Button
- 26 Light Button
- 27 Multiroom Button
- 28 Macro Buttons
- 29 Sleep Button
- 30 Night Mode Button
- 31 OSD Button
- 32 Tone Control Button
- 33 Mute Button
- 34 AM/FM Button
- 35 Channel Up/Down Selector
- 36 Transport Play Buttons
- 37 Delay Select Button
- 38 Speaker Select Button
- 39 Memory Button
- 40 Stereo Mode Select Button
- 41 DTS Neo:6 Mode Select Button
- 42 DTS Digital Mode Select Button
- 43 Dolby Mode Select Button
- 44 6/8-Channel Input Select
- 45 SPL Select Button
- 46 EzSet Microphone Sensor
- 47 Lens

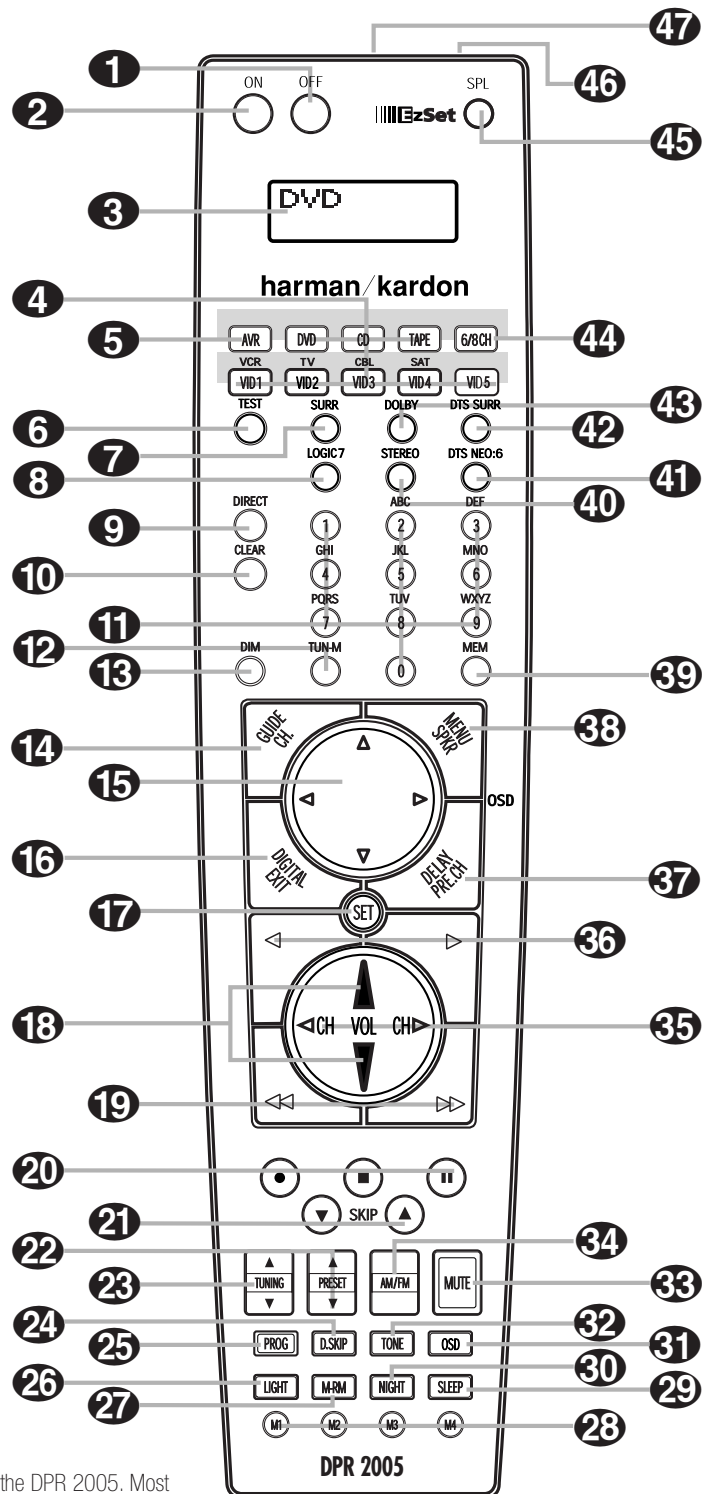

NOTES:

- The function names shown here are each button's feature when used with the DPR 2005. Most buttons have additional functions when used with other devices. When a button is pressed, the function name will appear in the bottom line of the LCD Information Display 3.
- The jack on the upper right side of the remote is reserved for future use. Do not remove the plug provided or connect any device to the jack.
- To make it easier to follow the instructions that refer to this illustration, a larger copy may be downloaded from the Product Support section for this product at www.harmankardon.com.

MAIN REMOTE CONTROL FUNCTIONS

IMPORTANT NOTE: The DPR 2005's remote may be programmed to control up to nine devices, including the DPR 2005. Before using the remote, it is important to remember to press the **Input Selector Button 4** that corresponds to the unit you wish to operate. In addition, the DPR 2005's remote is shipped from the factory to operate the DPR 2005 and most Harman Kardon CD or DVD players and cassette decks. The remote is also capable of operating a wide variety of other products using the control codes that are part of the remote. Before using the remote with other products, follow the instructions on pages 41 – 50 to program the proper codes for the products in your system.

It is also important to remember that many of the buttons on the remote take on different functions, depending on the product selected using the **Input Selectors 4**. The descriptions shown here primarily detail the functions of the remote when it is used to operate the DPR 2005.

- 1 Power Off Button:** Press this button to place the DPR 2005 or a selected device in the Standby mode. Note that this will turn off the main room functions, but if the Multiroom system is activated, it will continue to function.
- 2 Power On Button:** Press this button to turn on the power to a device selected by first pressing one of the **Input Selectors 4**.
- 3 LCD Information Display:** This two-line screen displays various information depending on the commands that have been entered into the remote.
- 4 Input Selectors:** Pressing one of these buttons will perform three actions at the same time. First, if the DPR 2005 is not turned on, this will power up the unit. Next, it will select the source shown on the button as the input to the DPR 2005. Finally, it will change the remote control so that it controls the device selected. After pressing one of these buttons you must press the **AVR Selector Button 5** again to operate the DPR 2005's functions with the remote.
- 5 AVR Selector:** Pressing this button will switch the remote so that it will operate the DPR 2005's functions. If the DPR 2005 is in the Standby mode, it will also turn the DPR 2005 on.
- 6 Test Button:** Press this button to begin the sequence used to calibrate the DPR 2005's output levels. (See page 27 for more information on calibrating the DPR 2005.)

7 DSP Surround Mode Selector: Press this button to select one of the DSP surround modes, such as VMaX, Hall 1, Hall 2 or Theater. Each press of the button selects another mode. (See page 32 for more information on surround modes.)

8 Logic 7 Mode Select Button: Press this button to select from among the available Logic 7 surround modes. (See page 32 for the available Logic 7 options.)

9 Direct Button: Press this button when the tuner is in use to start the sequence for direct entry of a station's frequency. After pressing the button, simply press the proper **Numeric Keys 11** to select a station. (See page 35 for more information on the tuner.)

10 Clear Button: When programming the remote or using the EzSet feature, press this button to cancel the current function. When using the remote to enter frequencies for direct tuner access, press this button to clear previous entries.

11 Numeric Keys: These buttons serve as a ten-button numeric keypad to enter tuner preset positions. They are also used to select channel numbers when TV, Cable or SAT has been selected on the remote, or to select track numbers on a CD, DVD or LD player, depending on how the remote has been programmed. These buttons are also used to enter letters and numbers when renaming devices in the LCD Information Display. (See page 48 for more information on renaming devices and keys.)

12 Tuning Mode Button: Press this button to change the tuner mode between manual and automatic. When the button is pressed so that **AUTO / STEREO** appears in the **Upper Display Line 16** and in the on-screen display, only stations with acceptable signal quality will be tuned, and the tuner will play FM stations in stereo, when available. In the **AUTO** mode, when the **Tuning Up/Down Buttons 5 23 E** are pressed, the unit will automatically search for the next available station with good signal strength. When this button is pressed so that **MANUAL / MONO** appears in the **Upper Display Line 16** and in the on-screen display each press of the **Tuning Up/Down Buttons 5 23 E** will move the frequency up or down in single-step increments. When the FM band is in use, pressing the button so that the **MANUAL** mode is activated will enable you to tune stations with weak signals by changing to monaural reception. (See page 35 for more information on tuner operation.)

13 Dim Button: This button activates the Dimmer function, which reduces the brightness of the front-panel display, or turns it off entirely. Press the button once to reduce the display brightness by 50%, and press it again within five seconds and the main display will go completely dark. Note that this setting is temporary; regardless of any changes, the display will always return to full brightness when the DPR is turned on. The blue accent lighting inside the volume control will go out when the panel lights are at half brightness or when they are fully dimmed.

14 Channel Select Button: This button is used to start the process of setting the DPR 2005's output levels to an external source. Once this button is pressed, press the **▲/▼** on the **Navigation Button 15** to select the channel being adjusted, then press the **Set Button 17**, followed by the **▲/▼** on the **Navigation Button 15** again, to change the level setting. (See page 36 for more information.)

15 Navigation Button: This single disc-like button is used to navigate through the on-screen configuration menus, to scroll through the options list and to select choices for the various settings such as delay, speakers, surround modes, digital inputs, etc. To use the button, simply press it left, right, up or down in the direction indicated by the **▲▼◀▶** icons printed on the button disc. Depending on the menu being used, pressing the button will either change a specific menu or configuration choice or it will change the option shown in the on-screen or front-panel display. The sections in this manual describing the unit's individual features and configuration options contain specific information on how the navigation controls are used.

16 Digital Select Button: Press this button to assign one of the digital inputs **16 17 H J** to a source. (See page 33 for more information on using digital inputs.)

17 Set Button: This button is used to enter settings into the DPR 2005's memory. It is also used in the setup procedures for delay time, speaker configuration and channel output level adjustment.

18 Volume Up/Down Buttons: These controls share the disc in the lower portion of the remote with the **Channel Up/Down Selector 35**. To raise the volume, press the button marked **▲** by pressing towards the top of the remote. To lower the volume, press the button marked **▼** by pressing towards the bottom of the remote. The **◀▶** buttons on the left and right sides of this disc change channels up or down when the TV, cable box or satellite **Input Selectors 4** have been pressed.

MAIN REMOTE CONTROL FUNCTIONS

19 Transport Fast-Play/Scan Buttons: These buttons have no direct function on the DPR 2005, but they are used when the remote is programmed for a compatible DVD, CD or tape player. Pressing these buttons will transmit a fast-play forward, fast-play reverse, or fast-forward or fast-reverse scan command, according to the capabilities of the player being controlled. In the factory default setting, these buttons are preprogrammed with the remote codes for Harman Kardon DVD players so that you may control a compatible player even when the remote is directly controlling the DPR, a TV set, or a cable or satellite set-top box.

20 Main Transport Controls: These buttons have no direct function on the DPR 2005 but are used when the remote is programmed for a compatible DVD, CD or tape player. Pressing these buttons will transmit a stop (■), record (●), or pause (⏸) command, according to the capabilities of the player being controlled. In the factory default setting, these buttons are programmed with the remote codes for Harman Kardon DVD players so that you may control a compatible player even when the remote is directly controlling the DPR, a TV set, or a cable or satellite set-top box.

21 Track Skip Up/Down Buttons: These buttons do not have a direct function with the DPR 2005, but when used with a compatibly programmed CD or DVD changer will change the track or chapter currently being played. In the factory default setting, these buttons are programmed with the remote codes for Harman Kardon DVD players so that you may control a compatible player even when the remote is directly controlling the DPR, a TV set, or a cable or satellite set-top box.

22 Preset Up/Down Button: When the tuner is in use, press this button to scroll through the stations programmed into the DPR 2005's memory.

23 Tuning Up/Down Button: Press this button when the tuner is in use to change the station to one with a higher or lower frequency. When the tuner is in the **MANUAL / MONO** mode, each tap of the Selector will increase or decrease the frequency by one increment. When the tuner receives a strong-enough signal for adequate reception, **MANUAL TUNED** will appear in the **Lower Display Line 17** and in the on-screen display. When the tuner is in the **AUTO / STEREO** mode, press the button once, and the tuner will scan for a station with acceptable signal strength. When the next higher- or lower-frequency station with a strong enough signal is tuned, the frequency scan will stop and the **Lower Display Line 17** and the on-screen display will indicate **AUTO TUNED**. When an FM Stereo station is tuned, the display will read **AUTO ST TUNED**. See page 35 for more information on using the tuner.

24 Disc Skip Button: This button has no direct function for the DPR 2005 but may be used to change the disc in a CD or DVD changer when the remote is programmed for that type of device.

25 Program Button: This button is used to begin the process of programming the remote. Press and hold this button for three seconds to place the remote in the programming mode. Once the red LED under the **Set Button 17** lights, release the button. You may then select from the desired option. (See pages 41 – 50 for more information on configuring the remote.)

26 Light Button: Press this button to activate the remote's backlight for ease of use in darkened rooms.

27 Multiroom Button: Press this button to begin the process of activating the multiroom system or to change the input or volume level for the second zone. (See page 39 for more information on the multiroom system.)

28 Macro Buttons: Press these buttons to store or recall a "Macro", which is a preprogrammed sequence of commands stored in the remote. (See page 44 for more information on macros.)

29 Sleep Button: Press this button to place the unit in the Sleep mode. After the time shown in the display, the DPR 2005 will automatically go into the Standby mode. Each press of the button changes the time until turn-off in the following order:

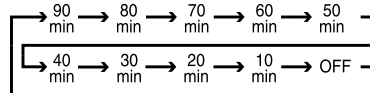

When the Sleep timer is in use, the front-panel displays and other indicators will dim to half-brightness.

30 Night Mode Button: Press this button to activate the Night mode. This mode is available in specially encoded Dolby Digital sources, and it preserves dialogue (center channel) intelligibility at low volume levels.

31 OSD Button: Press this button to activate or turn off the On-Screen Display (OSD) system used to set up or adjust the DPR 2005's parameters.

32 Tone Control Button: This button controls the tone mode settings, enabling adjustment of the bass and treble boost/cut. You may also use it to take the tone controls out of the signal path completely for "flat" response. The first press of the button displays a **TONE IN** message in the **Lower Display Line 17** and in the on-screen display. To take the controls out of the signal path press either of the **▲/▼ Navigation Buttons 15** until the display reads **TONE OUT**. To change the bass or treble settings, press the button again until the desired option appears in the **Lower Display Line 17** and on-screen display and then press either of the **▲/▼ Navigation**

Buttons 15 to enter the desired boost or cut setting. See page 30 for more information on the tone controls.

33 Mute Button: Press this button to momentarily silence the DPR 2005 or TV set being controlled, depending on which device has been selected.

34 AM/FM Button: Press this button to select the DPR 2005's tuner as the listening choice. Pressing this button when the tuner is already in use will select between the AM and FM bands.

35 Channel Up/Down Selector: These selectors share the disc in the lower portion of the remote with the **Volume Up/Down Buttons 18**. They have no function when the DPR is being controlled, but when programmed for use with a VCR, TV, cable box, satellite receiver or other similar product they will change the channel up or down. See pages 41 – 50 for more information on programming the remote.

36 Transport Play Buttons: These buttons have no direct function on the DPR 2005, but they are used when the remote is programmed for a compatible DVD, CD or tape player. Pressing these buttons will transmit a forward- or reverse-play command, according to the capabilities of the player being controlled. In the factory default setting, these buttons are programmed for Harman Kardon DVD players so that you may control a compatible player even when the remote is directly controlling the DPR, a TV set or a cable or satellite set-top box.

37 Delay Select Button: This button selects adjustments to the A/V Sync Delay and the individual channel delays. The first press of the button displays an **A / V SYNC DELAY** message in the **Lower Display Line 17** and in the on-screen display, which means that you may change the amount of time that all channels are delayed together behind the video. This enables you to compensate for the loss of lip sync that may be caused by digital video processing in your display or by television stations. To change the A/V Sync Delay, press the **Set Button 17** while the **A / V SYNC DELAY** message is visible and then use the **▲/▼ Navigation Button 15** to change the setting so that the sound and the video image are in sync. To change the delay for an individual output channel, press the **▲/▼ Navigation Button 15** until the desired channel name is shown, and then press the **Set Button 17**. Use the **▲/▼ Navigation Buttons 15** to change the delay amount. (See page 26 for more information on delay options.)

38 Speaker Select Button: Press this button to begin the process of configuring the DPR 2005's bass management system. Then press the **▲/▼ Navigation Button 15** to select the channel you wish to set up. Press the **Set Button 17** and

MAIN REMOTE CONTROL FUNCTIONS

then select another channel to configure. When all adjustments have been completed, press the **Set Button 17** twice to exit the settings and return to normal operation. (See page 24 for more information on speaker setup.)

39 Memory Button: Press this button to enter a radio station to the DPR 2005's preset memory. First, tune the desired station, and then press this button. Within five seconds of when you see the station's frequency flash in the **Upper Display Line 16** and in the on-screen display, press the numeric keys for the preset number between 01 and 30 that you wish to assign to the station. (See page 35 for more information.)

40 Stereo Mode Select Button: Press this button to select a stereo listening mode. When the button is pressed so that **SURROUND OFF** appears in the **Lower Display Line 17**, the AVR will operate in a bypass mode with true, fully analog, two-channel left/right stereo mode with no surround processing or bass management, as opposed to other modes where digital processing is used. When the button is pressed so that **SURROUND OFF** appears in the **Lower Display Line 17**, and the **DSP** and **SURROUND OFF Surround Mode Indicators 18** are lit, you will enjoy a two-channel presentation of the sound along with the benefits of bass management. Depending on whether your system is configured for 5.1 or 6.1/7.1 channels, the next press of the button will cause either **5 CH STEREO** or **7 CH STEREO** to appear, and the stereo signal will be routed to all five (or seven) speakers. (See page 32 for more information on stereo playback modes.)

41 DTS Neo:6 Mode Select Button: Press this button as needed to select one of the DTS Neo:6 modes. (See page 32 for the available DTS Neo:6 options.)

42 DTS Digital Mode Select Button: When a DTS-encoded digital source is playing, each press of this button will scroll through the available DTS modes. The specific choice of modes will vary according to the type of encoding on the disc and your system's speaker configuration. When a DTS source is not in use, this button has no function. (See page 32 for the available DTS digital options.)

43 Dolby Mode Select Button: This button is used to select from the available Dolby Surround modes. Each press of this button will select one of the Dolby Pro Logic II or Dolby Pro Logic IIx modes. When a Dolby Digital-encoded source is in use, the Dolby Digital mode may also be selected. (See page 32 for the available Dolby surround mode options.)

44 8-Channel Input Select: Press this button to select the device connected to the **8-Channel Direct Inputs 40**. (See page 30 for more information.)

45 SPL Select Button: This button activates the EzSet function to quickly and accurately calibrate the DPR 2005's output levels. When the button is pressed you will then need to select between automatic EzSet operation or using the remote as a manual SPL meter by pressing the **▲/▼ Navigation Button 15** until your choice appears in the remote's LCD display. Press the **Set Button 17** to enter the setting, and then follow the instructions as displayed in the LCD display. (For complete information, see page 27.)

46 EzSet Microphone Sensor: The microphone sensor that is used by the EzSet system is behind the three slots at the top of the remote control. When using EzSet to calibrate the DPR 2005, be certain that the slots are not covered. (See page 27 for more information on using EzSet.)

47 Lens: The infrared emitters behind the plastic lens at the top of the remote communicate the remote codes to the DPR 2005. Be certain that the lens is not covered when using the remote, and point the lens toward the DPR for best results. In learning mode, the remote receives IR codes to be learned through a sensor behind the lens.

NOTE: DO NOT remove the rubber plug that is supplied to cover the jack on the upper right side of the remote. The jack is not active and is reserved for future use.

INSTALLATION AND CONNECTIONS

System Installation

After unpacking the unit, locating it in a place with adequate ventilation and placing it on a solid surface capable of supporting its weight, you will need to make the connections to your audio and video equipment.

IMPORTANT NOTE: For your personal safety and to avoid possible damage to your equipment and speakers, it is always good practice to turn off and unplug the DPR and ALL source equipment from the AC output before making any audio or video system connections.

Audio Equipment Connections

We recommend that you use high-quality interconnect cables when making connections to source equipment and recorders to preserve the integrity of the signals.

1. Connect the analog output of a CD player to the **CD Inputs 10**.

NOTE: If your CD player has both fixed and variable audio outputs, it is best to use the fixed output unless you find that the input to the receiver is so low that the sound is noisy, or so high that it is distorted.

2. Connect the analog Play/Out jacks of a cassette deck, MD, CD-R or other audio recorder to the **Tape Inputs 1**. Connect the analog Record/In jacks on the recorder to the **Tape Outputs 11** on the DPR 2005.
3. Connect the output of any digital audio source such as such as a CD or DVD changer or player, advanced video game, a digital satellite receiver, HDTV tuner or digital cable set-top box or the output of a compatible computer sound card to the **Optical and Coaxial Digital Audio Inputs 16 17 H J**.
4. Connect the coaxial or optical **Digital Audio Outputs 18 19** on the rear panel of the DPR 2005 to the matching digital input connections on a CD-R or MiniDisc recorder.
5. Assemble the AM loop antenna supplied with the unit so that the tabs at the bottom of the antenna loop snap into the holes in the base. Connect it to the **AM and GND Screw Terminals 36**.

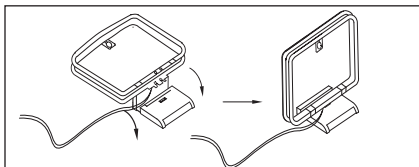

6. Connect the supplied FM antenna to the **FM (75-Ohm) Connection 35**. The FM antenna may be an external roof antenna, an inside powered or wire-lead antenna or a connection from a cable TV system. If the antenna or connection uses 300-

ohm twin-lead cable, you must use an optional 300-ohm-to-75-ohm adapter to make the connection.

7. Connect the front, center, surround and surround back speaker outputs **24 25 26 27** to the respective speakers.

To ensure that all the audio signals are carried to your speakers without loss of clarity or resolution, we suggest that you use high-quality speaker cable. Many brands of cable are available and the choice of cable may be influenced by the distance between your speakers and the receiver, the type of speakers you use, personal preferences and other factors. Your dealer or installer is a valuable resource to consult in selecting the proper cable.

Regardless of the brand of cable selected, we recommend that you use cable with a gauge of 14 or smaller. Remember that in specifying cable, the lower the number, the thicker the cable.

Cable with a gauge of 16 may be used for short runs of less than ten feet. We do not recommend that you use cables with an AWG equivalent of 18 or higher, due to the power loss and degradation in performance that will occur.

Cables that are run inside walls should have the appropriate markings to indicate listing with UL, CSA or other appropriate testing agency standards. Questions about running cables inside walls should be referred to your installer or a licensed electrician who is familiar with the NEC and/or the applicable building codes in your area.

When connecting wires to the speakers, be certain to observe proper polarity. Note that the positive (+) terminal of each speaker connection now carries a specific color code, as noted on page 8. However, most speakers still use a red terminal for the positive connection. Connect the "negative" or "black" wire to the same terminal on both the receiver and the speaker.

NOTE: While most speaker manufacturers adhere to an industry convention of using black terminals for negative and red ones for positive, some may vary from this configuration. To ensure proper phase and optimal performance, consult the identification plate on your speaker or the speaker's manual to verify polarity. If you do not know the polarity of your speaker, ask your dealer for advice before proceeding, or consult the speaker's manufacturer.

We also recommend that the length of cable used to connect speaker pairs be identical. For example, use the same length piece of cable to connect the front-left and front-right or surround-left and sur-

round-right speakers, even if the speakers are a different distance from the DPR 2005.

8. Connections to a subwoofer are normally made via a line-level audio connection from the **Subwoofer Output 14** to the line-level input of a subwoofer with a built-in amplifier. When a passive subwoofer is used, the connection first goes to a power amplifier, which will be connected to one or more subwoofer speakers. If you are using a powered subwoofer that does not have line-level input connections, follow the instructions furnished with the speaker for connection information.
9. If an external multichannel audio source with 5.1 outputs such as an external digital processor/decoder, DVD-Audio or SACD player is used, connect the outputs of that device to the **8-Channel Direct Inputs 15**.

Video Equipment Connections

Video equipment is connected in the same manner as audio components. Again, the use of high-quality interconnect cables is recommended to preserve signal quality.

1. Connect the composite video or S-Video Play/Out jack of a VCR, Personal Video Receiver (PVR) or DVD-Recorder to the **Video 1 or Video 2 Video Input Jacks 4 6** on the rear panel. Although any other video device may also be connected to these jacks, we particularly recommend that VCRs and PVRs be connected to the Video 1 Input Jacks so that you are able to take advantage of the remote control codes for these devices that are programmed for the "Video1/VCR" button of the unit's remote control.
2. Connect the composite video or S-Video Record/In jacks of a VCR, Personal Video Recorder (PVR) or DVD-Recorder to the **Video 1 or Video 2 Video Output Jacks 3 5** on the rear panel. Although any other video device may also be connected to these jacks, we particularly recommend that VCRs and PVRs be connected to the Video 1 Output Jacks so that you are able to take advantage of the remote control codes for these devices that are programmed for the "Video 1/VCR" button of the unit's remote control.
3. Connect the composite video or S-Video Play/Out jacks of any video playback device to the **Video 3 or Video 4 Video Input Jacks 1 2** on the rear panel. Although any type of video source device may be connected to these jacks, the remote control has the commands for the Video 3 inputs set to control a cable set-top box and the commands for the Video 4 inputs set to control a satellite receiver. However, you may reassign the commands for any type of device to either button on the remote using

INSTALLATION AND CONNECTIONS

the instruction shown for "Changing Devices" as shown on page 43. You may also learn the codes for the device connected to any input by following the instructions for "Learning Codes" shown on page 42.

4. Connect the composite video or S-Video and analog left/right audio outputs of a DVD player to the **DVD Input Jacks 7** on the rear panel.
5. Connect the optical or coaxial digital audio outputs of a DVD player, satellite receiver, cable box, HDTV tuner or video game to any of the **Optical or Coaxial Digital Inputs 16 17 H J**. The recommended connection for a DVD player is to use a Coaxial digital link connected to the Coaxial Digital Audio Input 1, but you may change the digital audio input assignment for any source using the **IN / OUT SETUP** menu as described on page 21 or the **Digital Input Selector E 16** on the front panel or remote, as described on page 33.

NOTE: When connecting a device such as a digital cable box or other set-top tuner product with a digital audio output, we recommend that you connect both the digital and analog outputs of the product to your DPR. The audio input polling feature of the DPR will then be able to make certain that you have a constant audio feed, since it will automatically switch the audio input to the analog jacks if the digital feed is interrupted or not available for a particular channel.

6. Connect the **Video Monitor Output 8** jacks on the receiver to the composite or S-Video input of your television monitor or video projector.
7. If your DVD Player has Y/Pr/Pb analog component video outputs, connect them to the **Component Video 1 Inputs 23**. Although this set of inputs may be assigned to any of the five video inputs on the DPR 2005, the factory default is for this input to be assigned to the **DVD Inputs 7**. Remember to make a digital audio connection between the DVD player and the DPR, with the **Coaxial Digital Input 1 16** being the factory default. For information on changing the input assignments for either the component video jacks or the DVD player's audio connection, see page 21.
8. If you have other devices with Y/Pr/Pb or RGB component video outputs, connect the source device to the **Component Video 2 Inputs 29**. The audio connections may be made to the **Video 4 Inputs 1 2 4 6** or the **Optical or Coaxial Digital Inputs 16 17 H J**. When using either of the Component Video Inputs, make certain that the audio and video inputs are properly configured in the **IN / OUT SETUP** menu, as described on page 21.

9. If the component video inputs are used, connect the **Component Video Monitor Outputs 30** to the component video inputs of your TV, projector or other display device.
10. If you have a camcorder, video game or other audio/video device that is connected to the DPR on a temporary, rather than permanent, basis, connect the audio, video and digital audio outputs of that device to the **Front-Panel Inputs H J K**. A device connected here is selected as the Video 5 input, and the digital inputs must be assigned to the Video 5 input. (See page 21 for more information on input configuration.)

Video Connection Notes:

- When the component video jacks are used, the on-screen menus are not visible and you must switch to the standard composite or S-Video input on your TV to view them. For this reason, we recommend that you always make a composite or S-Video connection between the DPR and your video display, even if all the sources in use have component video outputs.
- The DPR 2005 will accept either standard composite, S-Video or Y/Pr/Pb component video signals. However, it will not convert composite or S signals to component video. Component or composite video signals may only be viewed in their native formats.
- We strongly recommend that a composite or S-Video connection be made from any video source even when a component connection is the primary playback mode. This enables the DPR to provide a feed to a record output, provided that simultaneous composite and component playback are possible.

System and Power Connections

The DPR 2005 is designed for flexible use with multi-room systems, external control components and power amplifiers.

Main Room Remote Control Extension

If the receiver is placed behind a solid or smoked glass cabinet door, the obstruction may prevent the remote sensor from receiving commands. In this event, an optional remote sensor may be used. Connect the output of the remote sensor to the **Remote IR Input 32** jack.

If other components are also prevented from receiving remote commands, only one sensor is needed. Simply use this unit's sensor or a remote eye by running a connection from the **Remote IR Output 33** jack to the Remote IR Input jack on Harman Kardon or other compatible equipment.

Multiroom IR Link

The remote room IR receiver should be connected to the **Multiroom IR Input 31** jack on the DPR 2005's rear panel.

If other Harman Kardon compatible source equipment is part of the main room installation, the **Remote IR Output 33** jack on the rear panel should be connected to the IR IN jack on source equipment. This will enable the remote room location to control source equipment functions.

NOTE: All remotely controlled components must be linked together in a "daisy chain." Connect the **IR OUT** jack of one unit to the **IR IN** of the next to establish this chain.

Multiroom Audio Connections

The DPR 2005 is equipped with multizone capabilities that allow it to send an audio source to the remote zone that is different from the one selected for use in the main room. Please note that this capability applies to analog inputs from sources such as the DPR's tuner, tape decks or VCRs. If you wish to use a source such as a DVD or CD player that is normally connected via a digital connection, it is necessary to run an analog connection from the source to the DPR or to use the Main Downmix input option, as explained on page 39.

Depending on your system's requirement, three options are available for audio connection:

Option 1: Use high-quality, shielded audio interconnect cable from the DPR 2005's location to the remote room. In the remote room, connect the interconnect cable to an optional external stereo power amplifier. The amplifier will be connected to the room's speakers. At the DPR 2005, plug the audio interconnect cables into the **Multiroom Audio Outputs 9** on the DPR 2005's rear panel.

Option 2: Connect the **Multiroom Audio Outputs 9** on the DPR 2005 to the inputs of an optional stereo power amplifier. Run high-quality speaker wire from the amplifier to the speakers in the remote room.

Option 3: Taking advantage of the DPR 2005's built-in seven-channel amplifier, it is possible to use two of the amplifier channels to power speakers in the remote room. When using this option you will not be able to use the full 7.1-channel capabilities of the DPR 2005 in the main listening room, but you will be able to add another listening room without external power amplifiers. To use the internal amplifiers to power a remote zone, connect the speakers for the remote room location to the **Surround Back/Multiroom Speaker Outputs 26**. Before using the remote room you will need to configure the amplifiers for surround

INSTALLATION AND CONNECTIONS

operation by changing a setting (following the instructions shown on page 39) in the **MULTI-ROOM SETUP** menu.

NOTE: For all options, you may connect an optional IR sensor in the remote room to the DPR 2005 via an appropriate cable. Connect the sensor's cable to the **Multiroom IR Input** ❸ on the DPR 2005 and use the Zone II remote to control the room volume. Alternatively, you may install an optional volume control between the output of the amplifiers and the speakers.

A-BUS® Installation Connections

The DPR 2005 is among the very few receivers available today that offer built-in A-BUS Ready operation. When used with an optional A-BUS keypad or control module, you have all the benefits of remote zone operation without the need for an external power amplifier.

To use the DPR 2005 with an approved A-BUS product, simply connect the keypad or module that is in the remote room to the DPR 2005 using standard Category 5 wiring that is properly rated for the in-wall use specific to the installation. Terminate the wiring at the receiver end to a standard RJ-45 connector in compliance with the instructions furnished with the A-BUS module.

No further installation or adjustment is needed, as the A-BUS jack on the DPR 2005 routes the signals in and out of the keypad to their proper destination for power, signal source and control. The output fed to the A-BUS jack is determined by the DPR 2005's multiroom system and menus.

RS-232 Connections

The DPR 2005 is equipped with an **RS-232 Port** ❷ that may be used for two purposes. When the port is connected to a compatible, optional, external computer, keypad or control system the DPR 2005 is capable of bi-directional communications that enable the external system to control the DPR, and for the DPR to report status and handshake data back to the controller. Use of the RS-232 port for this type of control requires specific technical knowledge, and we recommend that any connection and programming for control be made by a trained installer or technician familiar with the equipment being used.

The RS-232 port may also be used as an access point through which the DPR 2005's operating system and surround mode memories may be updated via connection to a compatible computer. At the time that an upgrade is available, instructions for making the connection and installing the upgrade will be available through the Product Support area of the Harman Kardon Web site at harmankardon.com.

The physical connection to the DPR 2005's RS-232 port is a standard D-SUB 9 connection but to assure compatible and proper operation, specific software commands and pin wiring schemes may be required.

AC Power Connections

This unit is equipped with two accessory AC outlets. They may be used to power accessory devices, but they should not be used with high-current draw equipment such as power amplifiers. The total power draw to each outlet may not exceed 100 watts.

The **Switched AC Accessory Outlet** ❸ is powered only when the unit is on. This is recommended for devices that have a mechanical power switch that may be left in the "ON" position.

NOTE: Many audio and video products go into a Standby mode when they are used with switched outlets. This type of product may not operate properly when used with the switched outlet.

The **Unswitched AC Accessory Outlet** ❷ is powered as long as the DPR is plugged into a powered AC outlet.

The DPR 2005 features a removable power cord that allows wires to be run in advance to a complex installation so that the unit itself need not be installed until it is ready for connection. When all needed connections have been made, connect the AC Power cord to the **AC Power Cord Jack** ❶.

The DPR 2005 draws significantly more current than other household devices, such as computers, that use removable power cords. For that reason, it is important that only the cord supplied with the unit (or a direct replacement of identical capacity) be used.

Once the power cord is connected, you are almost ready to enjoy the DPR 2005's incredible power and fidelity!

OPERATION

Basic Operation

Once you have completed the initial setup and configuration of the DPR 2005, it is simple to operate and enjoy. The following instructions will help you maximize the enjoyment of your new receiver:

Turning the DPR 2005 On or Off

- When using the DPR 2005 for the first time, you must press the **Main Power Switch A** to turn the unit on. This places the unit in a Standby mode, as indicated by the **Standby/On Indicator 1** turning amber. Once the unit is in Standby, you may begin a listening session by pressing the **Standby/On Button 2** on the front panel, or the **Power On Button 2** or **AVR Selector 5 B** on the remote. This will turn the unit on and return the DPR to the input source that was last used. The unit may also be turned on from Standby by pressing any of the **Input Selector Buttons 4 34 44 C D** on the remote or the **Input Source Selector Button 8** on the front panel.

Whenever the DPR is turned on, you will see all of the front-panel indicators light up for a few seconds. This is normal, and it is part of the unit's power-on self test.

NOTE: After pressing one of the **Input Selector Buttons 4 34 44 C D** to turn the unit on, press the **AVR Selector 5 B** to set the remote control to the DPR 2005 functions.

To turn the unit off, simply press the **Standby/On Switch 1** on the front panel or the **Power Off Button 1 A** on the remote. Power will be shut off to any equipment plugged into the rear-panel **Switched AC Accessory Outlet 23** and the **Standby/On Indicator 1** will turn amber.

When the remote is used to turn the unit "off," it is actually placing the system in a Standby mode, as indicated by the amber lighting of the **Standby/On Indicator 1**.

- To program the DPR 2005 for automatic turn-off, press the **Sleep Button 29** on the remote. Each press of the button will decrease the time before shut-down in the following sequence:

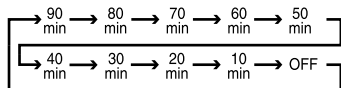

The sleep time will be displayed in the **Lower Display Line 17** and it will count down until the time has elapsed.

The front-panel display will dim to half brightness when the Sleep function is programmed. To cancel the Sleep function, press and hold the **Sleep Button 29** until the information display returns to normal brightness; and the words **SLEEP OFF** will appear in

the **Lower Display Line 17**. When the programmed sleep time has elapsed, the unit will turn off.

When you will be away from home for an extended period of time, it is always a good idea to turn the unit off with the front-panel **Main Power Switch A**.

NOTE: All preset memories are lost if the unit is left turned off by using the **Main Power Switch A** for more than four weeks.

Source Selection

- To select a source, press any of the **Input Selector Buttons 4 34 44 C D** on the remote.
- The input source may also be changed by pressing the front-panel **Input Source Selector Button 8**. Each press of the button will move the input selection through the list of available inputs.
- When a new input is selected, the DPR will automatically switch to the digital input (if selected), surround mode, component video input, A/V Sync Delay and Night Mode configurations that were in effect the last time that input was used. If the **BASS MGR** line on the **SPEAKER SETUP** menu (Fig. 7) was set to **INDEPENDENT**, as described on page 26, the settings for speaker size will also change to the preset values.
- The front-panel **Video 5 Inputs K**, **Optical Digital 3 Input H** or the **Coaxial Digital 3 Input J** may be used to connect a device such as a video game or camcorder to your home entertainment system on a temporary basis.
- As the input source is changed, the new input name will appear momentarily as an on-screen display in the lower third of the video display. The input name will also appear in the **Upper Display Line 16** and in the front-panel **Input Indicators 14**.

- When an audio source is selected, the last video input used remains routed to the **Video 1/Video 2 Outputs 3 5** and **Video Monitor Outputs 8**. This permits simultaneous viewing and listening to different sources.
- When a composite or S-Video source is selected, the video signal for that input will be routed to the **Video Monitor Output 8** and will be viewable on a TV monitor connected to the DPR 2005.

6-Channel/8-Channel Direct Input

- There are two input choices available for use with sources such as a DVD-Audio or SACD player that are connected to the **8-Channel Direct Inputs 15**. Select the appropriate input for your system and source equipment:

- The **6 CH DVD AUDIO** input should be used when the SBR and SBL inputs are not in use. When this input is used, the analog source is converted to digital so that you may use the same bass-management options for the direct input as you do with all other outputs. This input also mutes the unused SBL and SBR input jacks to prevent unwanted noise from interfering with system performance.

- The **8 CH DVD AUDIO** input should be used when an input is connected to all eight **8-Channel Direct Inputs 15**. When this input is in use, the analog source is converted to digital so that you may use the same Quadruple Crossover bass-management options for the direct input as you do with all other outputs.

Volume and Tone Control

- Adjust the volume to a comfortable level using the front-panel **Volume Control 13** or remote **Volume Up/Down Buttons 13 1**.
- To temporarily silence all speaker outputs, press the **Mute Button 33 K**. This will interrupt the output to all speakers and the headphone jack, but it will not affect any recording or dubbing that may be in progress. When the system is muted, the word **MUTE** will flash in the on-screen display and **Upper Display Line 16**, press the **Mute Buttons 33 K** again to return to normal operation.
- The unit's tone controls may be taken out of the signal path by pressing the **Tone Mode Button** on the front panel **3** or the remote **32**. The first press of either button will show a message in the on-screen display and **Lower Display Line 17** with the current status of the tone controls. The system default is **TONE IN**, which indicates that the bass and treble controls are active. Press the **▲/▼ Navigation Button 15** on the remote or the **▲/▼ Button 11** on the front panel to change the setting to **TONE OUT**, which is "flat" response without the tone controls being active.
- When the tone controls are active, the bass and treble boost/cut may be adjusted by first pressing the **Tone Mode Button** on the front panel **3** or the remote **32** until the desired setting (**BASS MODE** or **TREBLE MODE**) appears in the on-screen display and the **Lower Display Line 17**. Next, use the **▲/▼ Navigation Button 15** on the remote or the **▲/▼ Button** on the front panel **11** to change the setting as desired. The unit will return to normal operation within five seconds after the setting is changed.
- For private listening, simply place a standard 1/4" stereo headphone plug or adaptor into the

OPERATION

Headphone Jack **6** behind the door **12** on the front panel. The speakers will automatically mute and a two-channel stereo signal will be sent to the headphones. The **Lower Display Line** **17** will read **DOLBY H: BP**, indicating that the headphone output is in the Bypass mode, and to confirm that no processing is being used.

- When the headphones are in use, you may take advantage of the Dolby Headphone modes to bring added spaciousness to headphone listening. Press the **Dolby Mode Select Button** **43** or the **Surround Mode Selector** **4** to cycle through the three Dolby Headphone modes to select the one that you prefer.

Surround Mode Selection

One of the most important features of the DPR 2005 is its ability to reproduce a full multichannel sound field from digital sources, analog matrix surround-encoded programs and standard stereo programs.

Selection of a surround mode is based on personal taste, as well as the type of program source material being used. For example, motion pictures or TV programs bearing the logo of one of the major surround-encoding processes, such as Dolby Surround or DTS Stereo may be played in either the Dolby Digital, Dolby Pro Logic II Cinema, Dolby Pro Logic IIx Cinema, DTS Neo:6 Cinema, or Logic 7 Cinema surround modes, depending on the source material.

NOTE: Once a program has been encoded with matrix surround information, it retains the surround information as long as the program is available in stereo. Thus, movies with surround sound may be decoded via any of the analog surround modes such as Pro Logic II or IIx Cinema, Logic 7 Cinema or DTS Neo:6 Cinema, when they are broadcast via conventional TV stations, cable, pay-TV and satellite transmission. Also, a growing number of TV programs, sports broadcasts and radio dramas are also recorded in surround sound.

Even when a program is not listed as carrying intentional surround information, you may find that the Pro Logic II, Logic 7 Enhanced or DTS Neo:6, VMaX and the Hall or Theater modes often deliver enveloping surround presentations through the use of the natural information present in all stereo recordings.

Surround modes may be changed at any time by using either the front panel or remote control. To select a new surround mode from the front panel, first press the **Surround Mode Group Selector Button** **3** until the desired major surround mode group such as Dolby, DTS or Logic 7 is selected. Next, press the **Surround Mode Selector Button** **4** to choose the specific individual surround mode.

To select a surround mode using the remote, press the button for the surround mode group that includes the mode you wish to choose: **Dolby** **43**, **DTS Digital** **42**, **DTS Neo:6** **41**, **Logic 7** **8**, **Stereo** **40** or **DSP Surround** **7**. The first press of the button will show the current mode from that group if it is already in use, or the first available mode if you are currently using another mode. To cycle through the available modes in that group, press the button again until the desired mode appears in the **Lower Display Line** **17**, the on-screen display and in the front-panel **Surround Mode Indicators** **18**.

The Dolby Digital, Dolby Digital EX, DTS 5.1, DTS-ES Matrix and DTS-ES Discrete modes may only be selected when a digital input is in use. In addition, when a digital source is present, the DPR 2005 will automatically select and switch to the correct mode, regardless of the mode that has been previously selected. For more information on selecting digital sources, see the Digital Audio Playback section below.

When the 6-Channel/8-Channel direct inputs are in use, there is no surround processing, as these inputs take the analog output signals from an optional, external DVD-Audio or SACD player, or another source device, and carry them straight through to the volume control.

To listen to a program in traditional two-channel stereo, using the front left and front right speakers only (plus the subwoofer, if installed and configured), press the **Stereo Mode Select Button** **40** until **SURROUND OFF** appears in the **Lower Display Line** **17**. From the front panel, press the **Surround Mode Group Selector** **3** until the Stereo modes appear in the on-screen display and **Lower Display Line** **17**. Next, press the **Surround Mode Selector Button** **4** until **SURROUND OFF** appears in the on-screen display and **Lower Display Line** **17**.

Digital Audio Playback

Digital audio is a major advancement over analog surround processing systems. It delivers up to six discrete channels, and each channel reproduces full frequency range (20Hz to 20kHz) and offers dramatically improved dynamic range and significant improvements to signal-to-noise ratios. In addition, digital systems have the capability to deliver an additional channel that is specifically devoted to low-frequency information. This is the ".1" channel referred to when you see these systems described as "5.1," "6.1" or "7.1." The bass channel is separate from the other channels, but since it is intentionally bandwidth-limited, sound designers have given it that unique designation.

Dolby Digital

Dolby Digital is a standard part of DVD, and is available on specially encoded LD discs and satellite broadcasts and it is a part of the high-definition television (HDTV) system.

An optional, external RF demodulator is required to use the DPR 2005 to listen to the Dolby Digital soundtracks available on laser discs. Connect the RF output of the LD player to the demodulator and then connect the digital output of the demodulator to the **Optical** or **Coaxial Inputs** **16/17 H/J** of the DPR 2005. No demodulator is required for use with DVD players or DTS-encoded laser discs.

DTS

DTS is a digital audio system capable of delivering 5.1 or 6.1 discrete or matrix sound field reproduction. Although both DTS and Dolby Digital are digital, they use different methods of encoding the signals, and thus they require different decoding circuits to convert the digital signals back to analog.

DTS-encoded soundtracks are available on select DVD and LD discs, as well as on audio-only DTS discs. You may use any LD or CD player equipped with a digital output to play DTS-encoded discs with the DPR 2005. All that is required is to connect the player's output to either an **Optical** or **Coaxial Input** on the rear panel **16/17** or front panel **H/J**.

In order to listen to DVDs encoded with DTS soundtracks, the DVD player must be compatible with the DTS signal, which is indicated by the "DTS Digital Out" logo on the player's front panel. Some early DVD players were not able to play DTS-encoded DVDs. This does not indicate a problem with the DPR 2005, as those players cannot pass through the DTS signal. If you're in doubt as to the capability of your DVD player to handle DTS discs, consult the player's owner's manual.

IMPORTANT NOTE: Many DVD players have a default setting that does not pass through the DTS data, even though the machine is capable of doing so. If your DVD player has the "DTS Digital Out" logo but does not trigger DTS playback in the DPR 2005, change the player's settings in the "Audio" or "Bitstream" configuration menu so that DTS playback is enabled. The method for doing this will vary with each player. In some cases, the proper menu choice will be "Original," while in others it will be "DTS." Consult the owner's manual for your player to find the specific information to find the proper setting.

OPERATION

Selecting a Digital Source

To utilize either digital mode, you must have properly connected a digital source to the DPR 2005. Connect the digital outputs from DVD players, HDTV receivers, satellite systems or CD players to the **Optical** or **Coaxial Inputs 16 17 H J**. In order to provide a backup signal and a source for analog stereo recording, the analog outputs provided on digital source equipment should also be connected to their appropriate inputs on the DPR 2005 rear panel (e.g., connect the analog stereo audio output from a DVD to the **DVD Inputs 7** on the rear panel when you connect the source's digital outputs).

If you have not already configured an input for a digital source using the on-screen menus as shown on page 21, first select the desired input using the remote or front-panel controls, as outlined in this manual. Next, press the **Digital Select Button 16 E** and then using the **▲/▼ Navigation Button 15** on the remote or the **▲/▼ Buttons 11** on the front panel, choose any of the **OPTICAL** or **COAXIAL** inputs, as they appear in the **Upper Display Line 16** or on-screen display. When the digital source is playing, the DPR 2005 will automatically detect which type of digital data stream is being decoded and display that information in the **Upper Display Line 16**.

When both a digital and an analog connection are made between a source device and the DPR, the digital input is the default. If the digital stream is not present or is interrupted, the unit will automatically switch over to the analog inputs for the selected source.

Digital Bitstream and Surround Mode Indications

When a digital source is playing, the DPR senses the type of bitstream data that is present. Using this information, the correct surround mode will automatically be selected. For example, DTS bitstreams will cause the unit to switch to DTS decoding, and Dolby Digital bitstreams will enable Dolby Digital decoding. When the unit senses PCM data from CDs or LDs, you may select any of the standard surround modes, such as Dolby Pro Logic II or Logic 7. Since the range of available surround modes is dependent on the type of digital data that is present, the DPR 2005 shows you what type of signal is present. This will help you to understand the choice of modes.

When a digital source is first detected, the DPR 2005 will display a message to indicate the type of bitstream being received. This message will appear shortly after an input or surround mode is changed, and will remain in the **Lower Display Line 17** for about five seconds before that portion of the display returns to the normal surround mode indication.

For Dolby Digital and DTS sources, a three-digit indication will appear, showing the number of channels present in the data. An example of this type of display is 3/2/1.

The first number in the display message indicates how many discrete front-channel signals are present.

- A "3" tells you that separate front left, center and front right signals are available. This will be displayed for Dolby Digital 5.1 and DTS 5.1 programs.
- A "2" tells you that separate front left and right signals are available, but there is no discrete center channel signal. This will be displayed for Dolby Digital bitstreams that have stereo program material.
- A "1" tells you that there is only a mono channel available in the Dolby Digital bitstream.

The middle number in the display message indicates how many discrete surround channel signals are present.

- A "3" tells you that separate, discrete left surround, center surround and right surround signals are present. This is available only on discs with DTS-ES digital audio.
- A "2" tells you that separate surround left and right signals are available. This will be displayed for Dolby Digital 5.1 and DTS 5.1 programs.
- A "1" tells you that there is only a single, surround-encoded surround channel. This will appear for Dolby Digital bitstreams that have matrix encoding.
- A "0" indicates that there is no surround channel information. This will be displayed for two-channel stereo programs.

The last number indicates whether there is a discrete low-frequency effects (LFE) channel. This is the ".1" in the common abbreviation of "5.1" sound and it is a special channel that contains only bass frequencies.

- A ".1" tells you that an LFE channel is present. This will be displayed for Dolby Digital 5.1 and DTS 5.1 programs, as available.
- A "0" indicates that there is no LFE channel information available. However, even when there is no dedicated LFE channel, low-frequency sound will be present at the subwoofer output when the speaker configuration is set to show the presence of a subwoofer.
- The information in the right side of the display will tell you if the digital audio data contains a special flag signal that will automatically activate the appropriate 6.1 or 7.1 mode. This will be shown as EX-ON or EX-OFF for Dolby Digital bitstreams and ES-ON or ES-OFF for DTS bitstreams.

When Dolby Digital 3/2/1 or DTS or DTS-ES signals are being played, the DPR will automatically switch to the proper surround mode, and no other processing may be selected. When a Dolby Digital signal with a 3/1/0 or 2/0/0 signal is detected, you may select any of the Dolby surround modes.

It is always a good idea to check the channel data to make certain that it matches the audio logo information shown on the back of a DVD package. In some cases, you will see an indication for "2/0/0" even when the disc contains a full 5.1, or 3/2/1, signal. When this happens, check the audio output settings for your DVD player or the audio menu selections for the specific disc being played to be sure that the player is sending the correct signal to the DPR.

An **UNLOCK** message may appear in the **Lower Display Line 17**. This is your indication that the digital audio data stream has been interrupted or is no longer present. When that occurs, the unit's digital signal processor has no signal to lock onto, and is thus "unlocked." You may see this message when a DVD is first started until the stream is playing and the processor determines which mode to apply; or any time the data stream is stopped or paused, such as when the menus of some discs are displayed or when the player is switching between the different sections of a disc. You may also see the message when a satellite receiver, cable set-top or HDTV tuner is in use if the digital audio is temporarily interrupted when channels are changed or when a cable box switches from a channel with a digital data stream to a channel with analog audio only. The **UNLOCK** message is normal, and does not indicate any problem with your receiver. Rather, it tells you that the incoming data has simply been paused or is not present for a variety of possible reasons.

PCM Playback

PCM is the abbreviation for Pulse Code Modulation, which is the type of digital signal used for standard CD playback, and other non-Dolby Digital and non-DTS digital sources such as Mini-Disc. When a PCM signal is detected, the **Lower Display Line 17** will briefly show a message with the letters PCM, in addition to a readout of the sampling frequency of the digital signal.

In most cases, this will be **PCM 44.1kHz** or **PCM 48kHz**, though in the case of specially mastered, high-resolution audio discs, you will see a **PCM 96kHz** indication. Note that the sampling rate displayed is that of the incoming digital signal, and not the upsampled rate that may be applied to PCM sources when Dolby Pro Logic, Pro Logic II or Pro Logic IIx processing is applied, as shown on page 22.

During PCM playback you may select any surround mode except one of the Dolby Digital or DTS/DTS-ES modes. However, when a CD with HDCD encoding is being played you must select the Surround Off (stereo) mode to take advantage of the HDCD process.

HDCD Playback

High Definition Compatible Digital,[®] or HDCD, discs are recorded using a 20-bit encoding and other proprietary processing for the ultimate in CD listening. When

OPERATION

an HDCD-encoded disc is playing and the CD player is connected using a digital connection, the DPR 2005 will automatically recognize the HDCD encoding and activate the circuits required for proper playback, provided that the Surround Off mode is selected. An HDCD message will appear in the **Lower Display Line 17** to confirm the HDCD playback. HDCD playback is limited to two-channel stereo only.

Speaker/Channel Indicators

In addition to the bitstream indicators, the DPR 2005 features channel-input indicators that show how many channels of digital information are being received and/or whether the digital signal is interrupted (see Figure 15).

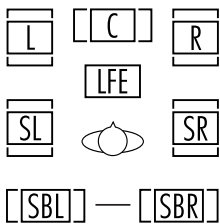

Figure 15

These indicators are the L/C/R/LFE/SL/SR/SBL/SBR letters that are inside the center boxes of the **Speaker/Channel Input Indicators 15** on the front-panel. When a standard analog signal is in use, only the "L" and "R" indicators will light, as analog signals have only left and right channels.

Digital signals, may have two, five, six or seven channels; depending on the program material, its method of transmission and the way in which it was encoded. When a digital signal is playing, the letters in these indicators will light in response to the signal being received. It is important to note that although Dolby Digital, for example, is referred to as a "5.1" system, not all Dolby Digital DVDs or programs are encoded for 5.1. Thus, it is sometimes normal for a DVD with a Dolby Digital soundtrack to trigger only the "L" and "R" indicators.

NOTE: Many DVD discs are recorded with both "5.1" and "2.0," and Dolby Digital and DTS versions of the same soundtrack. When playing a DVD, always be certain to check the type of material on the disc. Most discs show this information using icons on the back of the disc jacket. When a disc offers multiple soundtrack choices, you may have to make some adjustments to your DVD player (usually with the "Audio Select" button or in a menu screen on the disc) to send a full 5.1 feed to the DPR 2005 or to select between Dolby Digital or DTS. It is also possible for the type of signal feed to change during the course of a DVD's playback. In some cases, the previews or special material will be recorded in 2.0 audio, while the main feature is

available in 5.1 audio. The DPR 2005 will automatically sense changes to the bitstream and channel count and reflect them in these indicators.

The letters used by the **Speaker/Channel Input Indicators 15** also flash to indicate when a bitstream has been interrupted. This will happen when a digital input source is selected before the playback starts, or when a digital source such as a DVD is paused. The flashing indicators, along with the **UNL OCK** message in the **Lower Display Line 17**, remind you that the playback has stopped due to the absence of a digital signal and not through any fault of the DPR 2005. This is normal, and the digital playback will resume once the playback is started again.

Night Mode

A special feature of Dolby Digital is the Night mode, which enables specially encoded Dolby Digital input sources to be played back with full digital intelligibility while reducing the minimum peak level by 1/4 to 1/3. This prevents abruptly loud transitions from disturbing others, without reducing the impact of the digital source. The Night mode is available only when Dolby Digital signals with special data are being played.

The Night mode may be engaged when a Dolby Digital DVD is playing by pressing the **Night Mode Button 30** on the remote. Next, press the **▲/▼ Navigation Button 15** to select either the middle range or full compression versions of the Night mode. To turn the Night mode off, press the **▲/▼ Navigation Button 15** until the message in the lower third of the video display and in the **Lower Display Line 17** reads **D - RANGE OFF**.

The Night mode may also be selected to always be on at either level of compression using the options in the **DOLBY SURR** menu. See page 23 for information on using the menus to set this option.

MP3 Audio Playback

The DPR 2005 is one of the few receivers equipped for onboard decoding for the MP3 audio format used by computers and portable audio devices. By offering MP3 decoding, the DPR 2005 is able to deliver precise conversion of the digital signals to an analog output, along with the benefits of listening to the MP3 audio through the DPR 2005's high-power amplifier and the speakers from your surround system, rather than the smaller speakers and low-powered amplifiers typically used with computers.

To take advantage of the DPR 2005's MP3 capabilities, simply connect the S/P-DIF output of a computer's sound card or the S/P-DIF output of a portable digital audio device to either the rear panel **Digital Inputs 16/17** or the front-panel **Digital Inputs 16/17**. When the digital signal is available, the **Lower**

Display Line 17 will indicate that an MP3 bitstream is present, and the audio will begin playing.

NOTES:

- The DPR 2005 is only capable of playing signals in the MP3 (MPEG 1/Layer 3) format. It is not compatible with other computer audio codecs.
- The digital audio input signal may be either optical or coaxial, but the signal must be in the S/P-DIF format. Direct connection of USB or serial data outputs is not possible, even though the signals are in the MP3 format. If you have any questions about the data output format from your computer or a sound card, check with the device's owner's manual.
- If your computer or sound card's digital output is not capable of direct connection to the DPR 2005, you may use an optional, external transcoder to convert the USB output of a computer to a format compatible with the DPR.
- Due to the wide variation in MP3 formats and encoding speeds, it is possible that the DPR 2005 may not be compatible with all MP3 input signals. Some may produce unacceptable results or may not be decoded. This is not a fault of either the computer or the DPR 2005, but rather a by-product of the unpredictable nature of MP3 playback.
- Even when your computer does not have a digital output that is compatible with the DPR 2005, you may connect the analog audio output available on virtually all computers to one of the DPR's analog audio inputs using an optional adaptor cable that converts the stereo mini plug commonly used for computer audio connections to the left/right RCA jacks used on the DPR. Connecting your computer to the DPR will enable you to take advantage of the high-quality audio reproduction possible with a home theater system, as well as enable the use of surround processing modes such as Logic 7, to greatly enhance downloaded or streaming audio playback.

IMPORTANT NOTES ON DIGITAL PLAYBACK:

- When the digital playback source is stopped, or in a pause, fast forward or search mode, digital audio data will momentarily stop, and the channel position letters inside the **Speaker/Channel Input Indicators 15** will flash and an **UNL OCK** message may appear. This is normal and does not indicate a problem with either the DPR 2005 or the source machine. The DPR 2005 will return to digital playback as soon as the data is available.

OPERATION

- Some source devices, particularly cable set-top boxes, will switch back and forth between digital and analog audio outputs, depending on the channel being watched. To avoid losing sound with this type of product, it is recommended that you connect both the digital and analog audio outputs of the source to the DPR 2005, with the digital audio input set as the default following the steps shown on page 21. The DPR will monitor the digital data stream and when it is interrupted the sound will mute briefly and possibly display an **UNLOCK** message while it switches to the analog audio input. This switching is not a fault of either the DPR or the cable box, as it is caused by the use of different audio technologies on different channels by the cable company or program supplier.
- Although the DPR 2005 will decode virtually all current DVD movies, CDs and HDTV sources, it may not be compatible with future digital sources.
- When a digital source is playing, you may not be able to select some of the analog surround modes such as Dolby Pro Logic II, Dolby Pro Logic IIx, Hall, Theater or Logic 7.
- When a Dolby Digital or DTS source is playing, it is not possible to make an analog recording using the **Tape Outputs 11** and **Video 1** or **Video 2 Audio Outputs 3 5**. However, the digital signals will be passed through to the **Digital Audio Outputs 18 19 J**.

Tuner Operation

The DPR 2005's tuner is capable of tuning AM, FM and FM Stereo broadcast stations. Stations may be tuned manually, or they may be stored as favorite station presets and recalled from a 30-position memory.

Station Selection

1. Press the **AM/FM Button 34** on the remote to select the tuner as an input. The tuner may be selected from the front panel by either pressing the **Input Source Selector 8** until the tuner is active or by pressing the **Tuner Band Selector 6**.
2. Press the **AM/FM Button 34** or **Tuner Band Selector 6** again to switch between AM and FM so that the desired frequency band is selected.
3. Press the **Tuning Mode Selector 9 12** to select manual or automatic tuning.

When the button is pressed so that **AUTO** or **AUTO/STEREO** appears in the **Upper Display Line 16**, each press of the **Tuning Selectors 5 23** will put the tuner in a scan mode that seeks the next higher or lower frequency

station with acceptable signal strength. An **AUTO ST TUNED** indication will momentarily appear when the station stops at a stereo FM station, and an **AUTO TUNED** indication will momentarily appear when an AM or monaural FM station is tuned. Press the Tuning buttons again to scan to the next station.

When the button is pressed so that **MANUAL** or **MANUAL/MONO** appears in the **Upper Display Line 16**, each tap of the **Tuning Selectors 5 23** will increase or decrease the frequency by one increment. When the tuner receives a strong enough signal for adequate reception, **MANUAL TUNED** will appear in the **Lower Display Line 17**.

4. Stations may also be tuned directly in either the automatic or manual mode. To enter a station's frequency directly, first select the AM or FM band as desired by pressing the **AM/FM Button 6 34**. Next, press the **Direct Button 9**. Within five seconds of when **DIRECT IN** scrolls in the **Upper Display Line 16**, enter the station frequency by pressing the **Numeric Keys 11**. If you press an incorrect button while entering a direct frequency, press the **Clear Button 10** to start over.

NOTE: When the FM reception of a station is weak, audio quality will be increased by switching to Mono mode by pressing the **Tuning Mode Button 9 12** so that **MANUAL/MONO** appears momentarily in the **Upper Display Line 16** and then goes out. This will also activate manual tuning mode.

Preset Tuning

Using the remote, up to 30 stations may be stored in the DPR 2005's memory for easy recall using the front-panel controls or the remote.

To enter a station into the memory, first tune the station using the steps outlined above. Then:

1. Press the **Memory Button 39** on the remote; the station's frequency will flash.
2. Within five seconds, press the **Numeric Keys 11** corresponding to the memory location where you wish to store this station's frequency. Once entered, the preset number will appear in the **Upper Display Line 16**.
3. Repeat the process after tuning any additional stations to be preset.

Recalling Preset Stations

- To manually select a station previously entered in the preset memory, press the **Numeric Keys 11** for the desired station's memory location.

- To manually scroll through the list of preset stations, press the **Preset Stations Selector Button 7 22** on the front panel or remote.

Tape Recording

In normal operation, the audio or video source selected for listening through the DPR 2005 is sent to the record outputs. This means that any program you are watching or listening to may be recorded simply by placing machines connected to the outputs for **Tape Outputs 11** or **Video 1/Video 2 Outputs 3 5** in the record mode.

When a digital audio recorder is connected to the **Digital Audio Outputs 18 19 J**, you are able to record the digital signal using a CD-R, MiniDisc or other digital recording system.

NOTES:

- The digital outputs are active only when a digital signal is present, and they do not convert an analog input to a digital signal, or change the format of the digital signal. In addition, the digital recorder must be compatible with the output signal. For example, the PCM digital input from a CD player may be recorded on a CD-R or MiniDisc, but Dolby Digital or DTS signals may not.
- The **Front-Panel Video 5 K** and **Coaxial 3 J** jacks may be configured for use as an output, allowing connection to a recorder, when the steps shown in the section below are followed.
- Please obey the copyright restrictions on any material you copy. Unauthorized duplication of copyrighted materials is prohibited by law.

Front-Panel Connections

In addition to the rear-panel digital and analog outputs, the DPR 2005 offers Harman Kardon's exclusive configurable front-panel output-jack feature. For easy connection of portable devices, you may switch the front-panel **Video 5 Jacks K** or the **Coaxial Digital 3 Jack J** from an input to an output by following these steps:

1. Press the **OSD Button 31** to view the **MASTER MENU** (Figure 1).
2. Press the **Set Button 17** to enter the **IN/OUT SETUP** menu (Figure 2).
3. Press the **Navigation Button 15** so that the on-screen **→** cursor is next to **VIDEO 5** or **COAXIAL 3**, depending on which jack you wish to switch to an output.

OPERATION

4. Press the **Set Button** **17** and then press the **Navigation Button** **15** so that the word **OUT** is highlighted.
5. Press the **Set Button** **17** to enter the change.
6. Press the **OSD Button** **31** to exit the menus and return to normal operation.

Once the setting is made, the **Input/Output Status Indicator** **1** will turn red, indicating that the jacks are now an output, instead of in the default setting as an input. Once changed to an output, the setting will remain as long as the DPR 2005 is turned on, unless the setting is changed in the OSD menu system, as described above. However, once the DPR 2005 is turned off, the setting is cancelled. When the unit is turned on again, the front-panel jacks will return to their normal default setting as an input. If you wish to use the jacks as an output at a future time, the setting must be changed again using the OSD menu system, as described above.

Output Level Trim Adjustment

Normal output level adjustment for the DPR 2005 is established using the test tone, as outlined on pages 27 – 29. In some cases, however, it may be desirable to adjust the output levels using program material such as a test disc, or a selection you are familiar with. Additionally, the output level for the subwoofer can only be adjusted using this procedure.

To adjust the output levels using program material, first set the reference volume for the front left and front right channels using the **Volume Control** **13 18 1**.

If you are using a disc with test signals or an external signal generator as the source used when the output levels are being trimmed, you may use the remote as an SPL meter to guide you to the correct level settings. To use the EzSet remote as an SPL meter, follow the instructions on page 29.

Once the reference level has been set, press the **Channel Select Button** **14** and **FRONT LEVEL** will appear in the **Lower Display Line** **17**. To change the level, first press the **Set Button** **17**, and then use the **Navigation Button** **15** to raise or lower the level. DO NOT use the volume control, as this will alter the reference setting.

Once the change has been made, press the **Set Button** **17** and then press the **Navigation Button** **15** to select the next output-channel location that you wish to adjust. To adjust the subwoofer level, press the **Navigation Button** **15** until **WOOFER LEVEL** appears in the **Lower Display Line** **17** or on-screen display.

Repeat the procedure as needed until all channels requiring adjustment have been set. When all adjustments have been made and no further adjustments are made for five seconds, the DPR 2005 will return to normal operation.

The channel output for any input may also be adjusted using the full-OSD on-screen menu system. First, set the volume to a comfortable listening level using the **Volume Control** **13 18 1**. Then, press the **OSD Button** **31** to bring up the **MASTER MENU** (Fig. 1). Press the **Navigation Button** **15** until the on-screen **→** cursor is next to the **CHANNEL ADJUST** line. Press the **Set Button** **17** to activate the **CHANNEL ADJUST** menu (Fig. 13).

Once the menu appears on your video screen, first use the **Navigation Button** **15** to move the on-screen **→** cursor so that it is next to the **TEST TONE** line. Press the **Navigation Button** **15** so that **OFF** is highlighted. This will turn off the test tone and allow you to use your external test disc or other source material as the reference. Then, use the **Navigation Button** **15** to select the channels to be adjusted. At each channel position, use the **Navigation Button** **15** to change the output level. Remember, the goal is to have the output level at each channel be equal when heard at the listening position.

If you wish to reset all the levels to their original factory default of 0dB offset, press the **Navigation Button** **15** so that the on-screen cursor is next to the **CHANNEL RESET** line and press the **Navigation Button** **15** so that the word **ON** is highlighted. After the levels are reset, resume the procedure outlined above to reset the levels to the desired settings. When all adjustments are done, press the **Navigation Button** **15** to move the on-screen **→** cursor so that it is next to **BACK TO MASTER MENU** and then press the **Set Button** **17** if you wish to go back to the main menu to make other adjustments. If you have no other adjustments to make, press the **OSD Button** **31** to exit the menu system.

NOTE: Output levels may be separately trimmed for each surround mode. If you wish to have different trim levels for a specific mode, select that mode and then follow the instructions shown above.

Dim Function

Since the DPR 2005 will often be used when movies or other video programming is viewed under low-light conditions, you may wish to lower the brightness of the front-panel displays and indicators so that they do not distract from the video presentation. You may dim the displays using the menu system, as shown on

page 37, or you may control the brightness directly from the remote.

Simply press the **Dim Button** **13** once to dim the front panel to half the normal brightness level; press it again to turn the displays off. Note that when the displays are dimmed or turned off, the **Standby/On Indicator** **1** will remain lit as a reminder that the DPR is still turned on.

Note that all changes to the front-panel brightness level remain in effect only until the DPR is turned off; the displays will return to full brightness after the DPR is turned on again. To return the displays to full brightness without turning the unit off, press the **Dim Button** **13** as needed until the displays are on.

In addition to lowering the brightness of the displays or turning them off completely, you may wish to have them appear whenever a button on the remote or front panel is pushed, and then gradually fade out after a set time period. You may do this by making the appropriate settings in the **VFD FADE TIME OUT** line of the **ADVANCED SELECT Menu** (Figure 16), as shown on page 37.

Memory Backup

This product is equipped with a memory backup system that preserves the system configuration information and tuner presets if the unit is accidentally unplugged or subjected to a power outage. This memory will last for at least four weeks, after which time all information must be reentered.

TROUBLESHOOTING GUIDE

SYMPTOM	CAUSE	SOLUTION
Unit does not function when Main Power Switch is pushed	<ul style="list-style-type: none"> No AC Power 	<ul style="list-style-type: none"> Make certain that the AC power cord is plugged into a live outlet Check to see whether the outlet is switch-controlled
Display lights, but no sound or picture	<ul style="list-style-type: none"> Intermittent input connections Mute is on Volume control is down 	<ul style="list-style-type: none"> Make certain that all input and speaker connections are secure Press Mute Button  Turn up the volume control
Unit turns on, but front-panel display does not light up	<ul style="list-style-type: none"> Display brightness is turned off 	<ul style="list-style-type: none"> Follow the instructions in the Display Brightness section on page 37 so that the display is set to VFD FULL
No sound from any speaker; light around power switch is red	<ul style="list-style-type: none"> Amplifier is in protection mode due to possible short Amplifier is in protection mode due to internal problems 	<ul style="list-style-type: none"> Check speaker wire connections for shorts at receiver and speaker ends Contact your local Harman Kardon service center
No sound from surround or center speakers	<ul style="list-style-type: none"> Incorrect surround mode Input is monaural Incorrect configuration Stereo or Mono program material 	<ul style="list-style-type: none"> Select a mode other than Stereo There is no surround information from mono sources Check speaker mode configuration The surround decoder may not create center- or rear-channel information from nonencoded programs
Unit does not respond to remote commands	<ul style="list-style-type: none"> Weak batteries in remote Wrong device selected Remote sensor is obscured 	<ul style="list-style-type: none"> Change remote batteries Press the DPR selector Make certain that the front-panel sensor is visible to the remote, or connect remote sensor
Intermittent buzzing in tuner	<ul style="list-style-type: none"> Local interference 	<ul style="list-style-type: none"> Move the unit or antenna away from computers, fluorescent lights, motors or other electrical appliances
An UNLOCK message appears in the display and/or the letters in the Channel Indicator display flash at the same time as the audio stops	<ul style="list-style-type: none"> The type of digital audio stream has been changed Digital audio feed paused 	<ul style="list-style-type: none"> Wait a second or two for the unit's processor to recognize the new data stream and automatically resume playback Resume DVD playback.



In addition to the items shown above, additional information on troubleshooting possible problems with your DPR 2005, or installation-related issues, may be found in the list of "Frequently Asked Questions" which is located in the Product Support section of our Web site at www.harmankardon.com.

Processor Reset

In the rare case where the unit's operation or the displays seem abnormal, the cause may involve the erratic operation of the system's memory or microprocessor.

To correct this problem, first unplug the unit from the AC wall outlet and wait at least three minutes. After the pause, reconnect the AC power cord and check the unit's operation. If the system still malfunctions, a system reset may clear the problem.

To clear the DPR 2005's entire system memory including tuner presets, output level settings, delay times and speaker configuration data, first put the unit

in Standby by pressing the **Standby/On Button** . Next, press and hold the **Surround Mode Group Selector**  and the **Tuning Mode Selector**  buttons for three seconds.

The unit will turn on automatically and display the **RESET** message in the **Upper Display Line** .

NOTE: Resetting the processor will erase any configuration settings you have made for speakers, output levels, surround modes, digital input assignments as well as the tuner presets. After a reset the unit will be returned to the factory presets, and all settings for these items must be reentered.

If the system is still operating incorrectly, there may have been an electronic discharge or severe AC line interference that has corrupted the memory or microprocessor.

If these steps do not solve the problem, consult an authorized Harman Kardon service center.

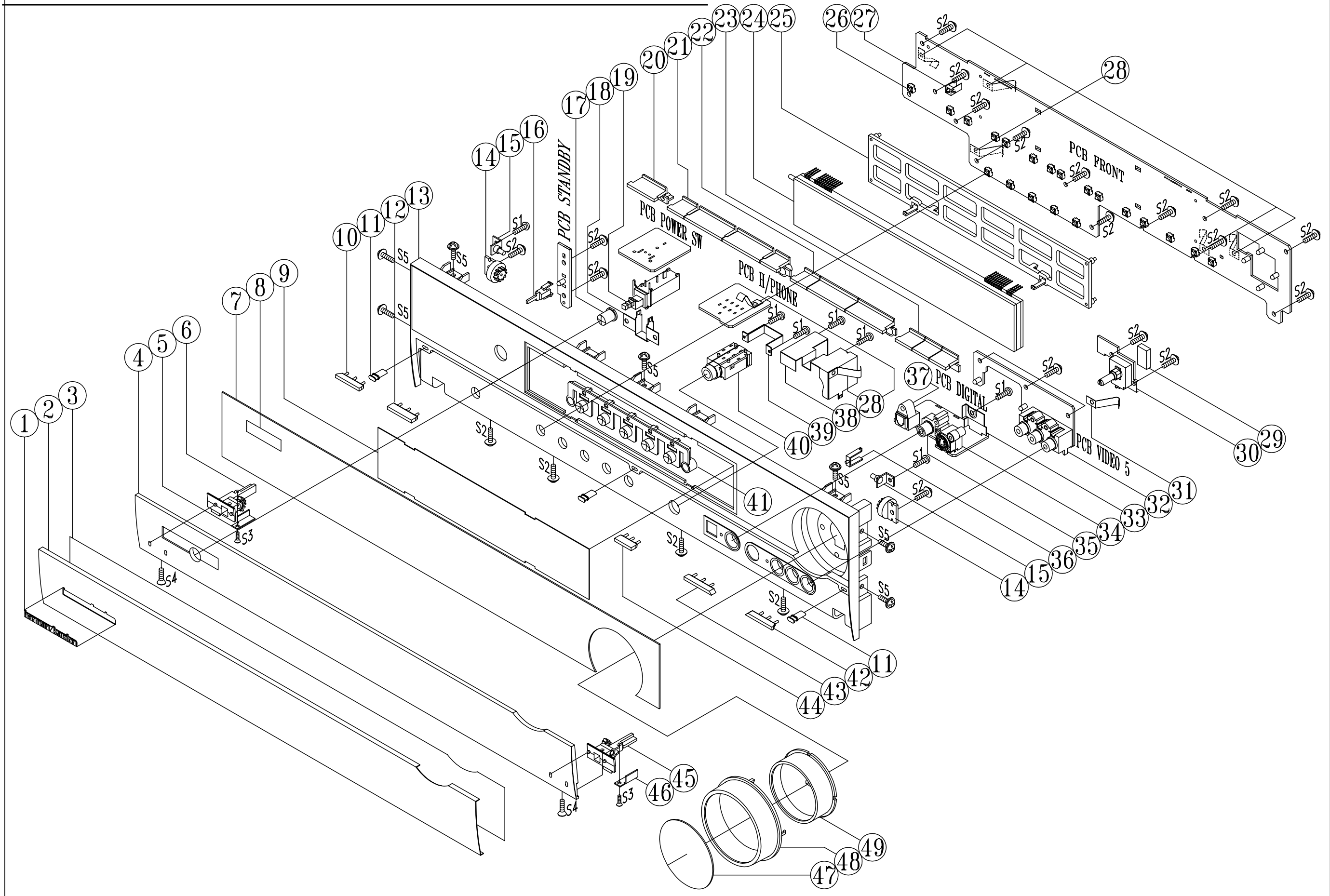

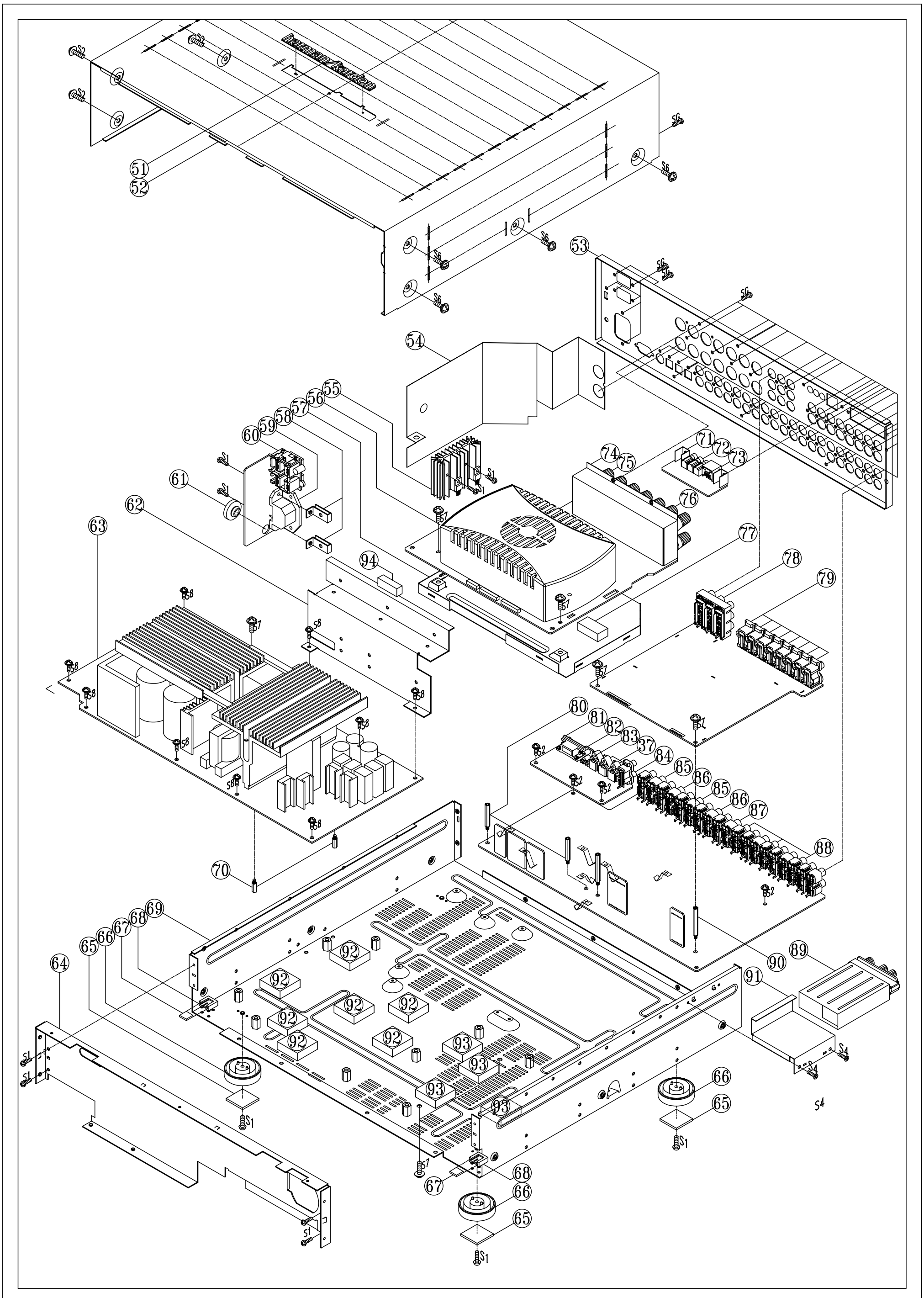

DPR1005/2005 Exploded View Parts List			
	See Drawing Page 1		
Ref #	Part #	Description	Qty
1	H01-ZMC12S20A00-2	AL BADGE HARMAN/KARDON SILVER	1
2	H01-ZMD03S00300-8	AL PANEL DOOR	1
3	H01-ZVD03DWT434-7	TAPE AL PANEL DOOR	1
4	H01-ZMD03S00200-6	AL DOOR	1
5	H01-ZMD03S05A00-8	BKT MAGNET LEFT	1
6	H01-ZPD0320GABK-8	DOOR HINGE-LEFT	1
7	H01-ZPD0319GABT-5	WINDOW DISPLAY DPR1005	1
8	ZKC1270HA00	LABEL "PLEASE"	1
9	H01-ZPC1018GART-7	FILTER VFD	1
10	H01-ZPD0301GASG-A	BTN DUMMY -1	1
11	ZFNR10803GY-1	DOOR RUBBER	3
12	H01-ZPD0302GASG-8	BTN DUMMY -2	1
13	H01-ZPD0312GAGY-A	PANEL FRONT DPR2005	1
14	H01-ZVD03GEAR01-5	DAMPER GEAR DP102	2
15	H01-ZMD03S04A00-7	BKT HINGE	2
16	H01-ZPD0314GAMW-5	INDICATOR STANBY	1
17	ZPD0303GAGY-8	BTN POWER	1
18	H01-ZMD03S09A00	BKT SHIELD POWER	1
19	H01-SWE4A21PDA-5	SW POWER SDKVB10100 5A 250V 4P	1
20	H01-ZPD0306GAGY-3	BTN 1 KEY	1
21	H01-ZPD0307GAGY-1	BTN 4KEY	1
22	H01-ZPD0310GAGY-3	BTN 3 KEY-A	1
23	H01-ZPD0308GAGY-A	BTN 3KEY-B	1
24	H01-VDHCA18LL03-7	FL HCA-18LL03	1
25	ZPC1017GABK-6	HOLDER VFD	1
26	H01-SWP1280APS1-8	SW TACH JTP1280AP	20
27	H01-ICRPM6938NN-3	IC-REMOTE RPM6938-RSIP-A3 RECEIVER 38KHZ	1
28	H01-ZMB01S02200-9	SPRING PLATE GND C5212 0.2T	14
29	ZUD040916BK-A	SPONGE VOLUMN	1
30	H01-SWE3A0505S1-9	VR ROT EC16B24204 5V 500U0A 10T 3P 0 0	1
31	H01-ZMD03S19A00	SPRING-A PLATE	1
32	H01-SORA3W019NN-9	JACK RCA 3P JC03W0191N	1
33	H01-ZMD03S03A00-6	BKT JACK	1
34	H01-SORAC5016NN-5	JACK S-VIDEO C50160272N	1
35	H01-SORA1JE01NN-0	JACK RCA 1P JE010003MN GND OR	1
36	H01-ZPD0318GAMW-8	INDICATOR VIDEO	2
37	H01-SOTOR179LBA-0	JACK D-LEM TORX-179L	3
38	H01-ZMD03S18A00	BKTSHIELD DIGITAL	1
39	H01-ZMB01S00100-5	BKT HEADPHONE JACK	1
40	H01-SOSS9CKX3NN-9	JACK PHONE 6.35 H70980110S 9P BK	1
41	H01-ZPD0309GAGY-8	BTN 5KEY	1
42	H01-ZPD0305GASG-2	BTN DUMMY-5	1
43	H01-ZPD0304GASG-4	BTN DUMMY-4	1
44	H01-ZPD0303GASG-6	BTN DUMMY -3	1
45	H01-ZPD0321GABK-6	DOOR HINGE-RIGHT	1
47	H01-ZMD03S05B00-A	BKT MAGNET RIGHT	1
47	H01-ZPD0317GACR-4	KNOB VOLUMN CAP	1
48	H01-ZPD0316GASG-A	KNOB COVER	1
49	H01-ZPD0315GAMW-3	KNOB VOLUMN	1
50		NOT USED	
	See Drawing Page 2		
51	H01-ZMGEN00GAGY-0	AL LOGO BADGE TOP	1
52	H01-ZMD03S08A00-0	COVER TOP	1
53	H01-ZMD03S11A00-2	PANEL REAR DPR1005	1
	H01-ZMD04S11A00-0	PANEL REAR DPR2005	1
54	H01-ZMD03S10A00	SHIELD AMP	1

Ref #	Part #	Description	Qty
55	H01-ZMD04HS0400	HEATSINK AMP	1
56	D2-GR00707-111	DPR1005 ASS'Y AMP MODULE GR0070-7 70W	1
	DR-GR01207-111	DPR2005 ASS'Y AMP MODULE GR0120-7 120W	1
57	H01-ZMD03S21A00-0	BKT SHIELD AMP	1
58	H01-ZMC12S19A00-2	BKT AC INLET	2
59	H01-SOXA27014NN-9	JACK A/C INLET 7014-NGP AC05-4S020A	1
60	H01-SOPA21275BK-3	JACK AC OUTLET 2P 110V FE 12.75MM 2 BK 0 0 A204D0043P	1
61	ZFNRB228700-8	POWER RUBBER	1
62	H01-ZMD03S02A00-5	BKT MIDDLE	1
63	H01-ZVD03S01300-8	DPR1005 SMPS ASS'Y SMPS KJP-7013 70W	1
	H01-ZVD04001300-8	DPR2005 SMPS ASS'Y SMPS KJP-10013 120W	1
64	H01-ZMD03S07A00-A	FRONT CHASSIS	1
65	ZFNR19720SB-5	FOOT RUBBER 19.7X19.7X2T BK	4
66	ZPC1103GAGY-A	FOOT 50MM 15.8MM	4
67	H01-ZMD03MAGN00-2	MAGNET	2
68	H01-ZPD0313GAGY-8	MAGNET CASE	2
69	H01-ZMD03S13A00-4	MAIN CHASSIS	1
70	H01-ZMD03S04AYE-5	STUD-3 H 11MM	2
71	H01-ZMC12S16A00-A	BKT GROUND	2
72	H01-SOJW2350SNN-A	JACK PHONE 3.6 EP-1401A 1P BK	3
73	SO0A18P8CNN-7	JACK-TELE SNAP-IN GOLDEN TELECOM GDL1-8P8C 8T BK 0 0	1
74	H01-ZMD03S20A00	SHIELD VIDEO TERMINAL	1
75	H01-SOPA81900NN-8	JACK TERMINAL SPKR 8P SH081136JP FE 19MM 8 -- 0 0	1
76	H01-SOPA619BKNN-7	JACK TERMINAL SPKR 6P SH0611708P FE 19MM 6 BK 0 0	1
77	ZUC1203AABK-A	SPONGE 15X30X8T BK	2
78	H01-SORA90173NN-6	JACK RCA 9P JB090173FN	1
79	H01-SORA11Y00NN-5	JACK RCA+S VIDEO C5016031DN	8
80	H01-ZMD03S05AYE-6	STUD STANDOFF HEX M4X0.7 6X27.5H	2
81	SOPA96063NN-0	JACK D-SUB 9P 87204-6063 W/DUST COVER BK	1
82	H01-SORA1J440CE-0	JACK RCA 1P PPJ-440CE	1
83	H01-SOTOT179LBA-7	JACK D-LEM TOTX-179L	1
84	H01-SORA20130JN-9	JACK RCA 2P JB020130JN	1
85	H01-SORA40RSANN-6	JACK RCA 4P JB040131ZN GN BN PP TA	2
86	H01-SORA40RSCNN-A	JACK RCA 4P JB040131QN WH BU RD GY	2
87	H01-SORA40GNDNN-7	JACK RCA 4P JB040131PN WWRR	1
88	H01-SORA64105NN-5	JACK RCA 6P JB060132PN	3
89	H01-ZVD03TUNE00-9	TUNER MODULE KST-MV014MA	1
90	H01-ZMD03S03AYE-4	STUD-1 H34MM	2
91	H01-ZMD04S12A00-1	SHIELD TUNER DPR2005	1
92	H01-ZUD0301AABK-A	SPONGE-UL 30X30X10T BK DPR2005	7
93	ZUC1201AABK-7	SPONGE 30X30X10T BK	4
94	ZQB0101AA00-4	SHIELD FOAM GASKET (WOORI)	1
S1	ZSTBM3010BB-5	SCREW ST BH 3X10	22
S2	ZSTWM3008BY-8	SCREW ST WPH 3X8	32
S3	ZSTPM2006BZ-9	SCREW S-TPG,WASHER 4.8MM,2.0X6,ZI-PLATED	2
S4	ZSTFM0308BN-9	SCREW S.T 3X8 F/H NI PLATED	4
S5	ZSTWM3006BY-1	SCREW S.T 3X6 W/H YELLOW ZINC PLATED	7
S6	ZSTWM4008BC-3	SCREW ST WPH 4X8 SILVER CHROM	8
S7	ZSMWM4008BZ-2	SCREW M.S M4X8 W/H ZN PLATED	6
S8	ZSMWM3008BZ-7	SCREW M.S M3X8 W/H ZN PLATED	10
SG	ZSTGM3010BB-3	SCREW ST BH 3X10 GROUND	49

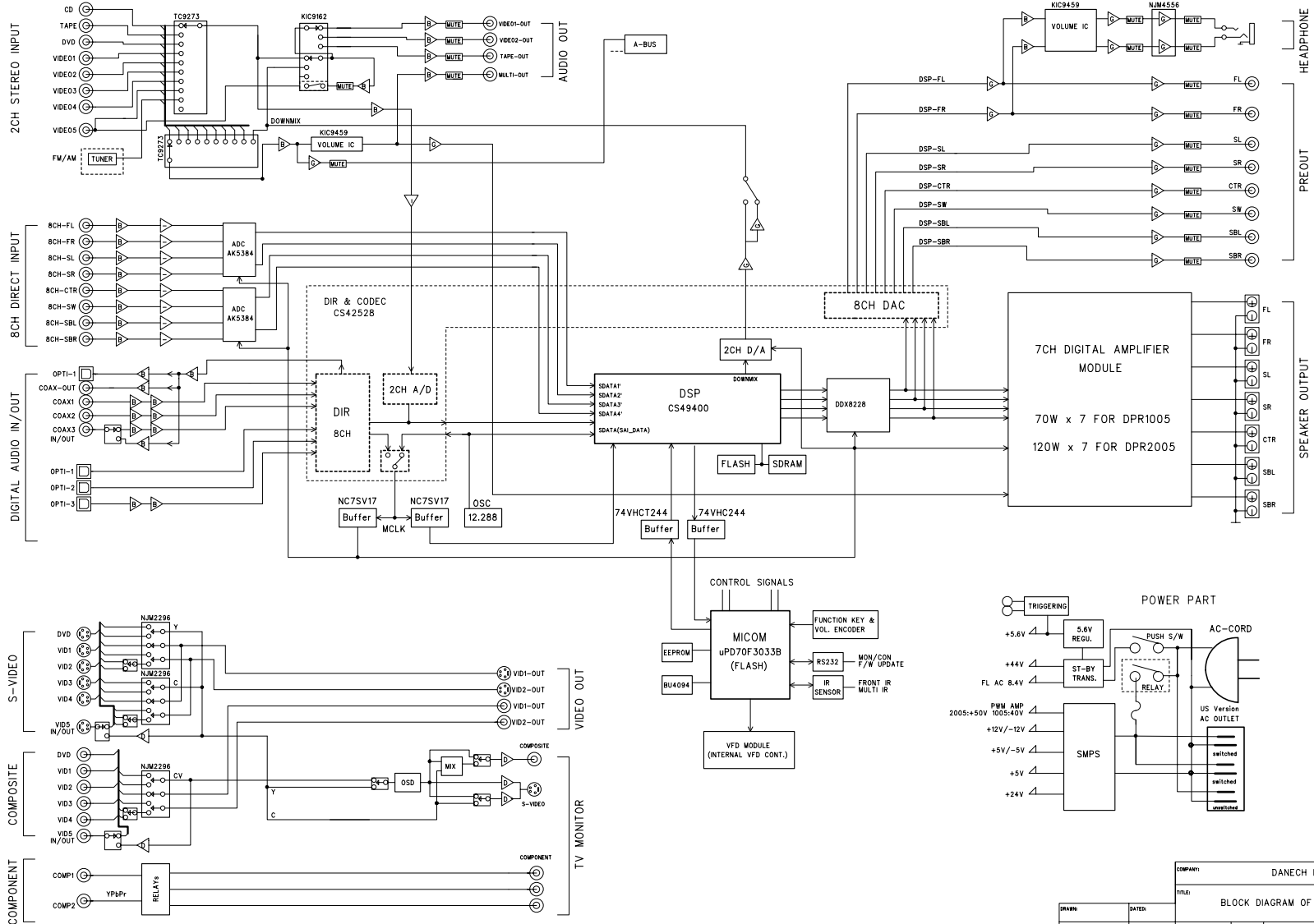

DRAWN:		DATE:		COMPANY: DANECH INC.	
CHECKED:		DATE:		TITLE: BLOCK DIAGRAM OF DPR1005/2005	
QUALITY CONTROL:	DATE:	CODE:	SIZE:	DRAWING NO:	REV: MP
RELEASED:	DATE:	SCALE:	SHEET: 1 OF 1		

harman/kardon**Service Bulletin**Service bulletin # HK2005-03 January 2005**Warranty labor rate: Does Not Apply**

To: All harman/kardon Service Centers

Model: DPR2005

Subject: Noise and Software Upgrade

In the event you receive a DPR2005 with the complaint: “there is noise in the right front channel when using the Speaker Optimizer function in either the 4 or 6 ohm impedance choice* ” direct the customer to contact harman/kardon for the solution.

An upgrade program and software is available for the DPR2005 through harman/kardon technical support free of charge, and can be obtained by calling: 516-255-HKHK (4545) during normal business hours. Full instructions for the upgrade are included along with a CD-ROM. The download requires a PC running Windows (OS of 98 SE or higher); full system requirements are disclosed in the written instructions. The upgrade will require a Serial port on the PC, and a standard male/female DB9 Serial cable.

MODEL	SERIAL NUMBER (120V)	SERIAL NUMBER (230V)	STATUS	ACTION
DPR2005	TF0005-01001 to TF0005-02400	TF0009-01001 to TF0009-01905	Noise in the right front channel when Speaker Optimizer function is in 4 or 6 ohm impedance	In need of Software Upgrade
DPR2005	TF0005-02401 and above	TF0009-01906 and above	Modified by Factory	None Required

* The ability to match the DPR2005's ideal output impedance to the loudspeaker @ 4, 6 or 8 ohms is not set by a mechanical switch, but is set electronically in the AUDIO SETUP on-screen menu described in detail in the DPR2005 owner's manual. It is called the "Speaker Optimizer" function.

harman/kardon**TECH TIPS****Troubleshooting tips and solutions to common service problems**

For models:

TIP# HKTT2003-01 Rev5

AVR7000/7200/7300/8000	AVR10
AVR100/200/300/500	DPR1001
AVR110/210/310/510	DPR1005
AVR120/220/320/520	DPR2005
AVR125/225/325/525	HK3370/3470/3375/3475
AVR130/230/330/430/630	HK3250
AVR135/235/335/435/635	

Subject: Backup Memory on AVR/DPR/HK series receivers

In the event of the complaint: “the receiver is losing its memory (any programmed system settings) when the unit is turned off, or after the unit is unplugged (briefly*)”:

Check and replace:

Model	Designator	Location	Description	Part number
AVR10	C712 D709	Front PCB	0.047 Farad 5.5v capacitor and 1N4148 diode	#3439247315 #2058322101
AVR7000	C730	Front PCB	0.047 Farad 5.5v capacitor	# P10790-ND or # J3432147324X
AVR7200	C106	Front PCB	0.047 Farad 5.5v capacitor	# P10790-ND
AVR7300	C657	DSP PCB	0.047 Farad 5.5v capacitor	# H01-CEZXA0479MN-5
AVR8000	C726	Front PCB	0.047 Farad 5.5v capacitor	# 55230310NR or # P10790-ND
AVR100/200	C412	Front PCB	0.047 Farad 5.5v capacitor	# CEGT-B473J-0J0
AVR300	C906	Front PCB	0.1Farad 5.5v capacitor	# J4433210421X or # P10791-ND
AVR500	C906	Front PCB	0.1Farad 5.5v capacitor	# J4433210421X or # P10791-ND
AVR110/210/310/510 AVR120/220/320/520	C216	Front PCB	0.047 Farad 5.5v capacitor	# P10790-ND
AVR125/225	C734,C885	Front PCB	two 0.1F capacitors in parallel	# BCESOHD104
AVR325/525	C106	Front PCB	0.047 Farad 5.5v capacitor	# P10790-ND
AVR130/230/330	BAT1	Front PCB	3.6v Battery	# HABGP40BVH3A3H
AVR135/235/335	BAT1	Front PCB	3.6v Battery	# HGP15BNH3A3H
AVR430/630	C657	DSP PCB	0.047 Farad 5.5v capacitor	# CEZXA0479MN-5
AVR435/635	C557	DSP PCB	0.047 Farad 5.5v capacitor	# H03-CEZXA0479MN-0
DPR1001	BC601	Main PCB	0.1Farad 5.5v capacitor	# CEGT-B104J-0J0
DPR1005/2005	C437	Processor PCB	0.047 Farad 5.5v capacitor	# CEZXA0479MN-5
HK3370/3470	C301	Front PCB	0.1Farad 5.5v capacitor	# CEGT-B104J-0J0
HK3375/3475	C301	Front PCB	0.1Farad 5.5v capacitor	# CEGT-B104J-0J0
HK3250	C712 D709	Front PCB	0.047 Farad 5.5v capacitor and 1N4148 diode	#3439247315 #2058322101

* After approximately two weeks of being disconnected from AC supply, even a normally functioning receiver may lose any programmed settings and switch to default settings. (Four weeks for the DPR1005 & 2005)

CIRCUIT DESCRIPTION

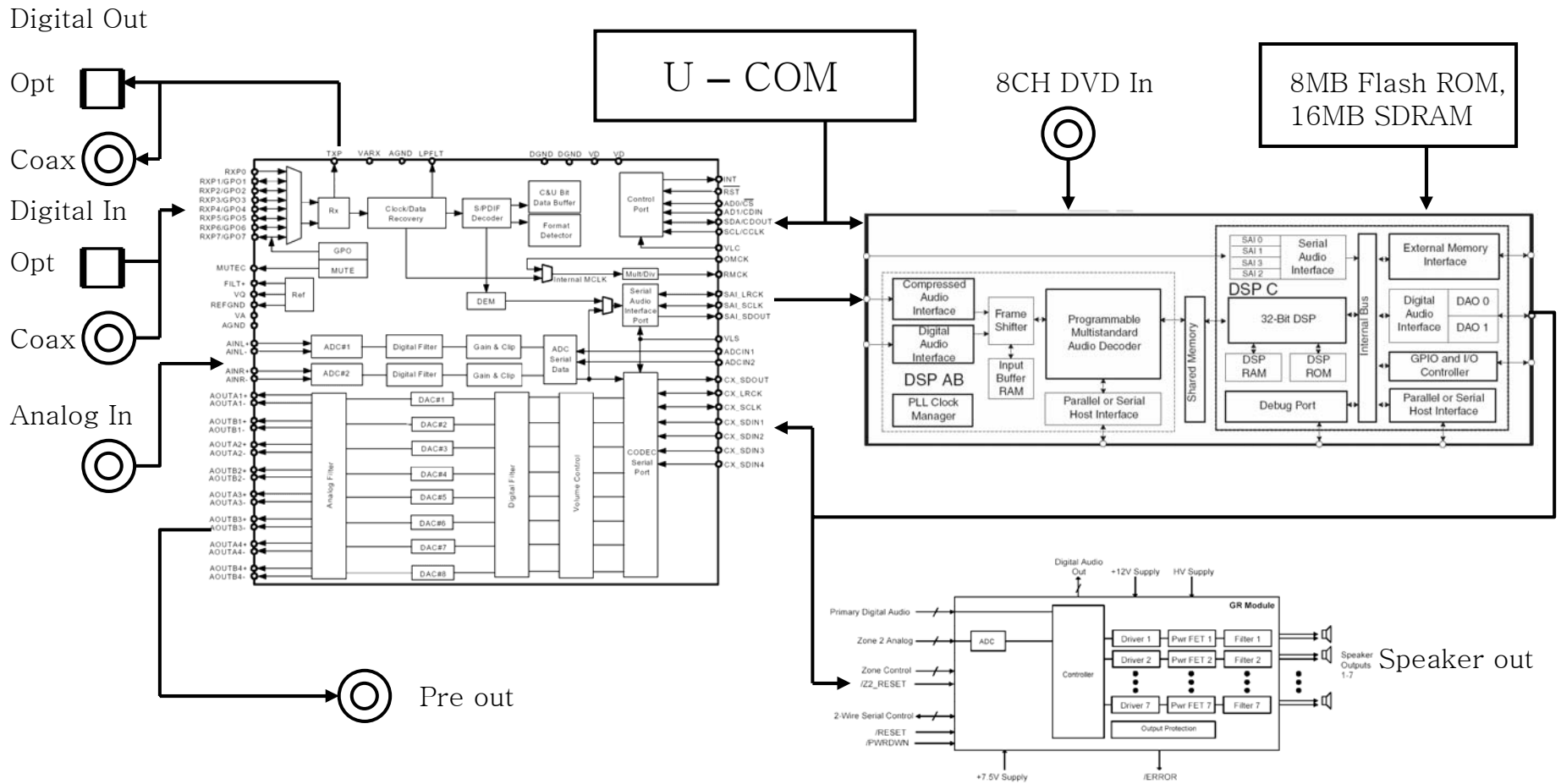

NOTE ON D2 POWER MODULE GR70 (DPR1005) AND GR120 (DPR2005)**Description of Normal LED Operation on the D2 Power Module:**

If the speaker impedance is too low for the amplifier and the individual channel's output current exceeds the safe operating point, the channel will shut down on current peaks and the LED will flicker RED.

After a module reset, the LED will be RED until the controller is initialized. When the power stages are enabled, the LED turns GREEN

If the amplifier reaches an unsafe operating temperature, the LED turns RED. After the amp cools off, it will revert to GREEN

If a channel is shorted, the LED turns RED. The system will shut down the power supply if a short is detected. In which case, there is a small flicker of RED and then off.

If the LED stays RED with the DPR ON and there is no speaker load, the D2 Power Module is likely defective.

Product (Power Module)	Part Number
GR70 (DPR1005)	#D2-GR00707-111
GR120 (DPR2005)	#D2-GR01207-111

GR70 (DPR1005) DATA SHEETS

Complete Class-D Amplifier Module

- Digital switching controller, driver & MOSFET output stage, output filter stage
- Designed for compliance with FCC, UL, CSA, CE requirements

High-Performance Sound

- 70 watts per channel into 8 ohms (FTC)
- >96 dB Dynamic Range
- <0.15% THD+N
- 20 Hz to 24 kHz +/-0.5dB frequency response

>90% Efficient

- Internal heat sink

Configurable Audio Processing

- Treble, Bass, Volume Control, and EQ per channel

- Dynamic range compression and output limiting
- Standard 2-wire serial interface controlled via micro controller or remote PC GUI

Pure Digital Path

- 8-channel digital audio inputs (32 -192 kHz, 16-24 bit) are mapped to 7 speaker output channels

Graceful Protection and Recovery

- Short-circuit, thermal, over-current faults

Powered Second Zone

- Dynamic configuration for 7 channels or 5 channels plus stereo second zone.
- 2-channel analog or independent rate digital input selection for second zone

The D2Audio™ GR70 is a fully self-contained 70 watts per channel digital amplifier module. The module enables rapid system design for manufacturers of home theater components.

The GR70 contains a high-performance digital switching controller, MOSFET output stages, and high-quality output filter stages.

The module is encased in an EMI-shielded package and tested for compliance with agency regulations to assist FCC Class-B, UL, CSA, and CE certification.

The GR70 is capable of driving up to 7 channels at 70 watts into an 8-ohm load with all channels driven per FTC specifications.

A configurable audio signal processor provides equalization, volume control, tone control, compression, and limiting.

A powered second zone allows for a fully independent amplifier zone. The amplifier can be dynamically configured as 7 channels or 5 channels with a stereo second zone. The second zone supports a stereo analog input or a fully independent digital audio input.

A separate digital audio output is also provided for the primary channels.

D2AUDIO GR70

- Complete digital amplifier for home theater components
- 70 watts/channel
- Up to 7 channels
- Pure digital audio signal path
- <.15% THD+N, >96dB dynamic range
- Configurable audio processing
- Powered 2nd Zone
- 90% efficient
- Graceful protection and recovery



3 SPECIFICATIONS

3.1 ABSOLUTE MAXIMUM RATINGS

Operation at or beyond the Absolute Maximum Ratings may result in permanent damage. Normal operation outside of the limits defined in this specification is not implied.

Parameter	Condition	Min	Max	Unit
High Voltage Supply (HV)	+38V DC Supply		40	V
Low Voltage Supply (LV)	+12V DC Supply		12.5	V
Signal Voltage Supply (SV)	+7.5V DC Supply		8.0	V
Digital Input Signal Level ¹	MCLK, SCLK, LRCLK, SDI[4:1], Z2_MCLK, Z2_LRCK, Z2_SCLK, Z2_SDI, SDA, SCL, /PWRDWN, /RESET, Z2_EN, Z2_AD, MD0, MD1	-0.6	3.90	V
Analog Input Signal Level ²	Peak to peak AC voltage		5	V
Input Current, any pin but supplies			+/-10	mA
Operating Temperature Range		0	50	°C
Storage Temperature Range		-20	60	°C
Lead Temperature	Soldering 10 Seconds		300	°C
Mechanical Shock	Any Axis non repetitive		TBD	G
Mechanical Shock	Any Axis Repetitive		TBD	G
Electrostatic Discharge	Machine Model		TBD	kV
Note 1: -0.6V undershoots and 3.9V overshoots allowed for 4ns maximum				
Note 2: Analog inputs are terminated with 10k ohms to analog ground, then AC coupled internally				

TABLE 2: Absolute Maximum Ratings

3.2 ELECTRICAL CHARACTERISTICS

T_A = 25° C, HV=38V, LV=12V, SV=7.5V, Ground = 0V

Symbol	Condition	Min	Typ	Max	Unit
V _{IL}				0.8	V
V _{IH}	Inputs except /RESET and /PWRDWN	2.0			V
V _{IH}	/RESET and /PWRDWN	3.0			V
V _{OH}	2 mA Load	2.4			V
V _{OL}	2 mA Load			0.4	V
I _L	Input Leakage - CMOS pins MCLK, LRCLK, SCLK, SDI, Z2_MCLK, Z2_LRCLK, Z2_SCLK, Z2_SDI			+/-10	uA
I _C	Input current on digital inputs with resistive pulls - /PWRDWN, /RESET, Z2_EN, Z2_AD_EN, MD0, MD1, SDA, SCL			+/-0.4	mA
R _I	Analog input resistance - all analog audio inputs		10		k Ohms
Z _S	Analog source output impedance			100	Ohms

TABLE 3: Electrical Characteristics

3.3 PERFORMANCE CHARACTERISTICS

Resistance load = 8Ω HV=38V, LV=12V, SV=7.5V

Specification	Condition	Min	Typ	Max	Unit
Output Power	All channels driven, FTC ³		70	70	W
Frequency Response	20 Hz to 24 kHz, at 1W output power	-0.5		0.5	dB
Dynamic Range	-60 dB input @ 1kHz	-96			dB
Output Distortion (THD+N)	20 Hz to 24 kHz, at 1W output power, MPC control bit off		0.12	0.15	%

Note 3: FTC spec: 30 minute pre-soak at 1/8th power, full power for 5 minutes, all channels driven simultaneously.

TABLE 4: Performance Characteristics

3.4 DC POWER REQUIREMENTS

T_A = 25°C, HV=38V, LV=12V, SV=7.5V, Ground = 0V

Symbol	Description	Condition	Min	Typ	Max	Unit
HV ⁴	High Voltage Supply				38	V
+12VDC	+12V Supply		11.75	12	12.5	V
+7.5VDC	+7.5V Supply		7.0	7.5	TBD	V
T _{srHV}	High Voltage Supply Slew Rate	See Chapter 5.8			20	V/S
HV	High Voltage Supply	All channels at full power output		18	TBD	A
+12VDC	+12V Supply			TBD	1.0	A
+7.5VDC	+7.5V Supply			TBD	0.85	A
HV	High Voltage Supply	/PWRDWN asserted		TBD	TBD	A
+12VDC	+12V Supply			TBD	1.0	A
+7.5VDC	+7.5V Supply			TBD	0.85	A

Note 4: The peak current requirement for the HV power supply is dependent on the overall system power output specification. The GR70 is designed to meet FTC power amplifier specifications for a sine wave continuous power measurement with all channels driven. Under normal conditions for most applications, all channels may not need to be driven at full power simultaneously. More typically, the power output requirement is 1/8 to 1/3 of the total amplifier output. However, if the amplifier is allowed to be driven into high distortion (“clipping”), the power supply current may approach 20% more than required for a full scale output. It is therefore up to the system designer to determine how much power output the module will be allowed to produce, and hence determine the maximum and average power supply current requirements.

TABLE 5: DC Power Requirements

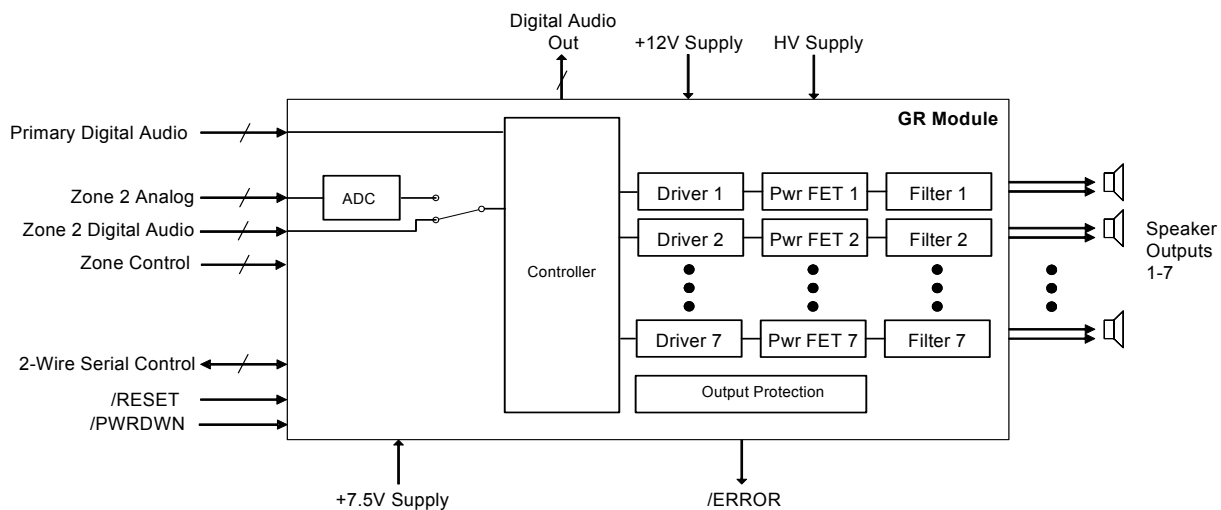

3.5 SWITCHING CHARACTERISTICS - SERIAL AUDIO PORT

$T_A = 25^\circ\text{C}$, HV=38V, LV=12V, SV=7.5V, Ground = 0V

Symbol	Description	Min	Typ	Max	Unit
$t_c\text{SCLK}$	SCLK frequency			12.5	MHz
$t_w\text{SCLK}$	SCLK pulse width (high and low)	40			ns
$t_s\text{LRCLK}$	LRCLK setup to SCLK rising	20			ns
$t_h\text{LRCLK}$	LRCLK hold from SCLK rising	20			ns
$t_s\text{SDI}$	SDI setup to SCLK rising	20			ns
$t_h\text{SDI}$	SDI hold from SCLK rising	20			ns
$t_d\text{SDO}$	SDO1-4 delay from SCLK falling			20	ns

TABLE 6: Serial Audio Port Timing

The second zone inputs Z2_SCLK, Z2_LRCLK and Z2_SDI have the same timing characteristics as the primary serial audio inputs. The Z2_LRCLK and Z2_SDI input timings are referenced to Z2_SCLK.

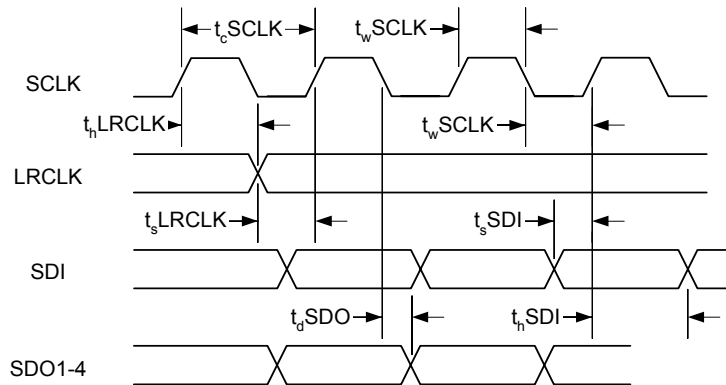

FIGURE 1: Serial Audio Port Timing

3.6 SWITCHING CHARACTERISTICS - CONTROL PORT

$T_A = 25^\circ\text{C}$, HV=38V, LV=12V, SV=7.5V, Ground = 0V

Symbol	Description	Min	Max	Unit
fSCL	SCL frequency		100	kHz
t_{buf}	Bus free time between transmissions	4.7		us
t_{wSCL}	SCL clock low	4.7		us
t_{wSCL}	SCL clock high	4.0		us
t_{sSTA}	Setup time for a (repeated) Start	4.7		us
t_{hSTA}	Start condition Hold time	4.0		us
t_{hSDA}	SDA hold from SCL falling (see note)	0		us
t_{sSDA}	SDA setup time to SCL rising	250		ns
t_{dSDA}	SDA delay time from SCL falling		3.5	us
t_{r}	Rise time of both SDA and SCL		1	us
t_{f}	Fall time of both SDA and SCL		300	ns
t_{sSTO}	Setup time for a Stop condition	4.7		us
Note: Data must be held sufficient time to bridge the 300ns transition time of SCL				
t_{dSDO}	SDO1-4 delay from SCLK falling		20	ns

TABLE 7: Control Port Timing

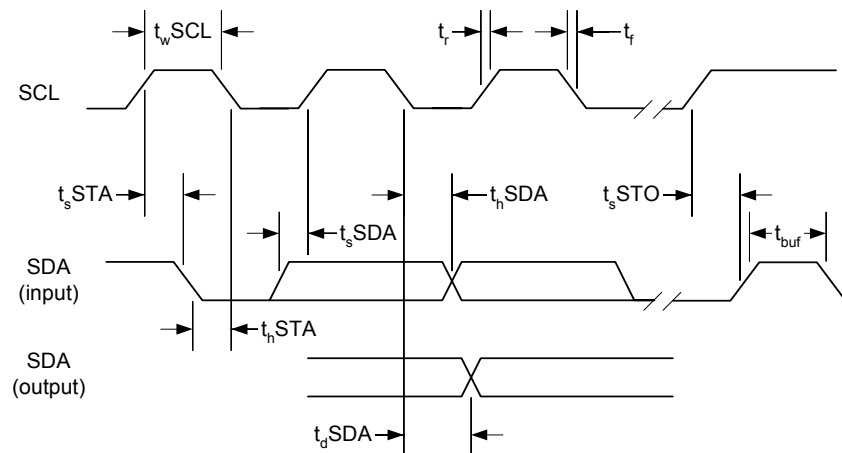

FIGURE 2: Control Port Timing

3.7 PERFORMANCE PLOTS

The following graphs show the amplifier's performance. All inputs are driven with the same input signal, all outputs are mapped to their respective input with unit gain. The output channels are tested one at a time and only the output channel being measured has a load. The other outputs are open.

3.7.1 FREQUENCY RESPONSE AT 1W (8Ω LOAD)

Conditions: Typical supplies, Room temperature, 1W output power

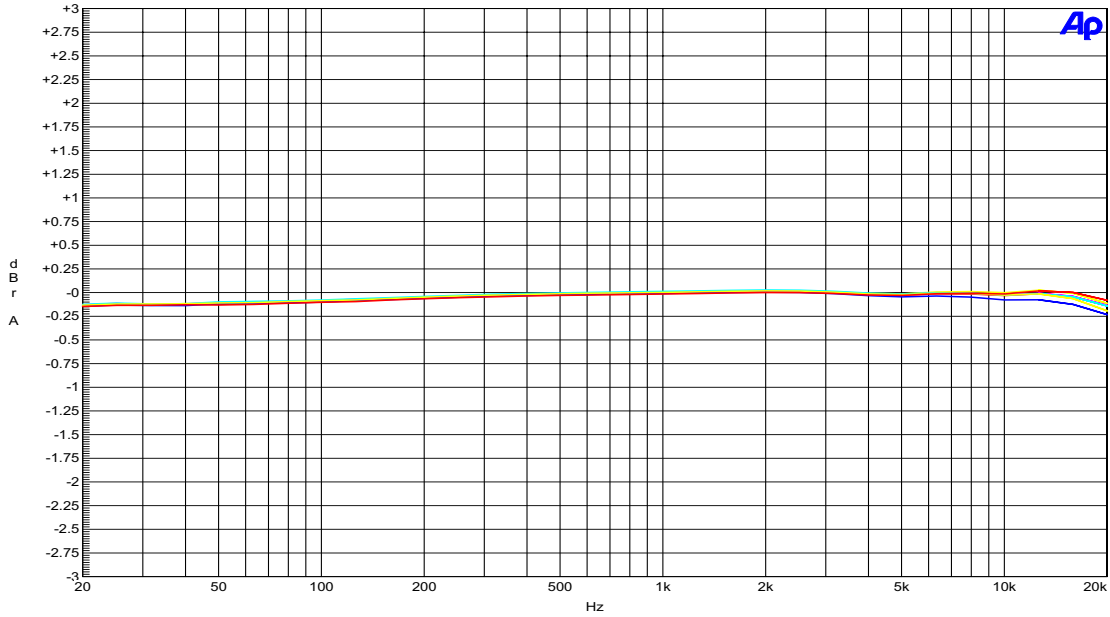

FIGURE 3: Frequency Response

3.7.2 THD+N VS. FREQUENCY (8Ω LOAD)

Conditions: Typical supplies, Room temperature, 1W output power

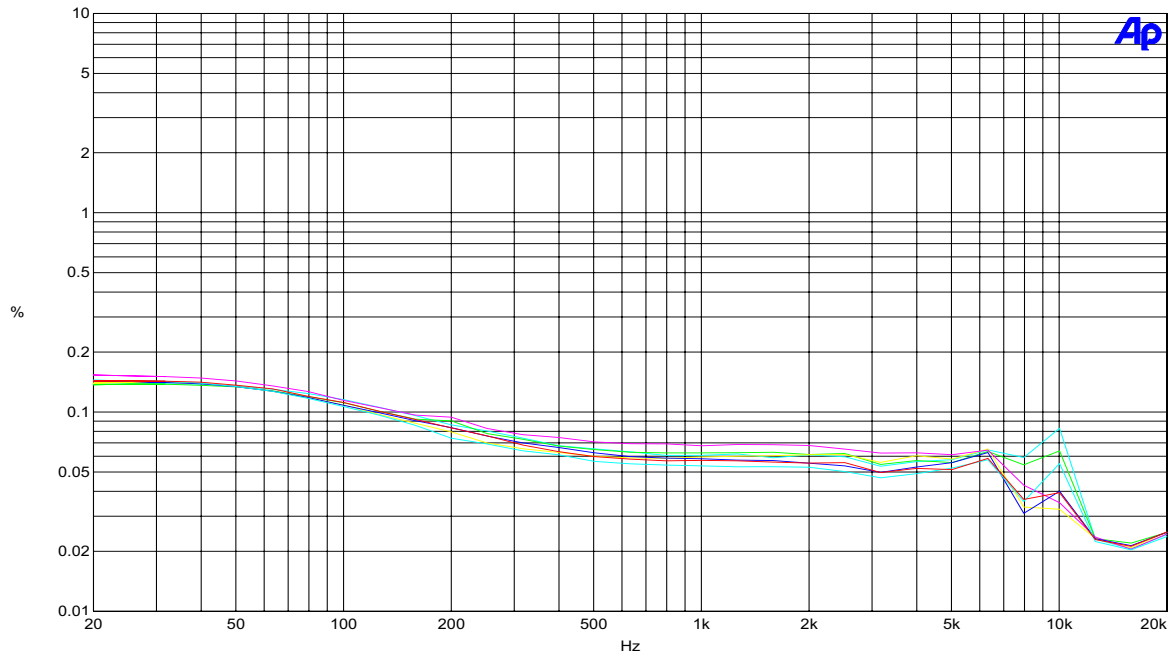

FIGURE 4: THD+N vs. Frequency

3.7.3 THD+N VS. OUTPUT POWER (8Ω LOAD)

Conditions: Typical supplies, Room temperature, 1kHz digital input

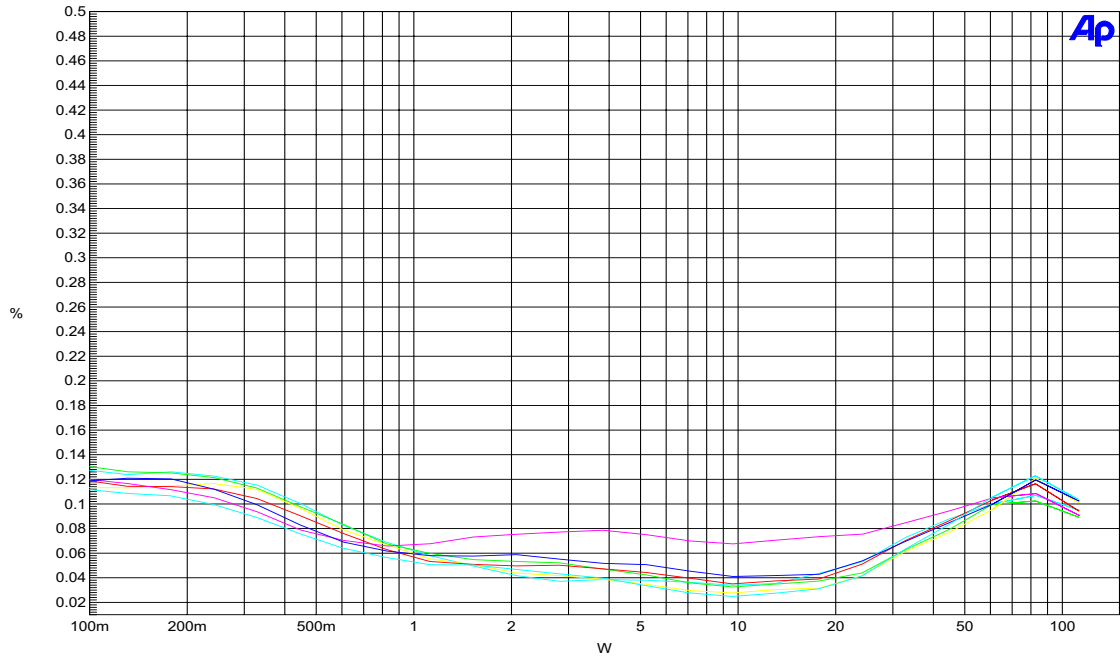
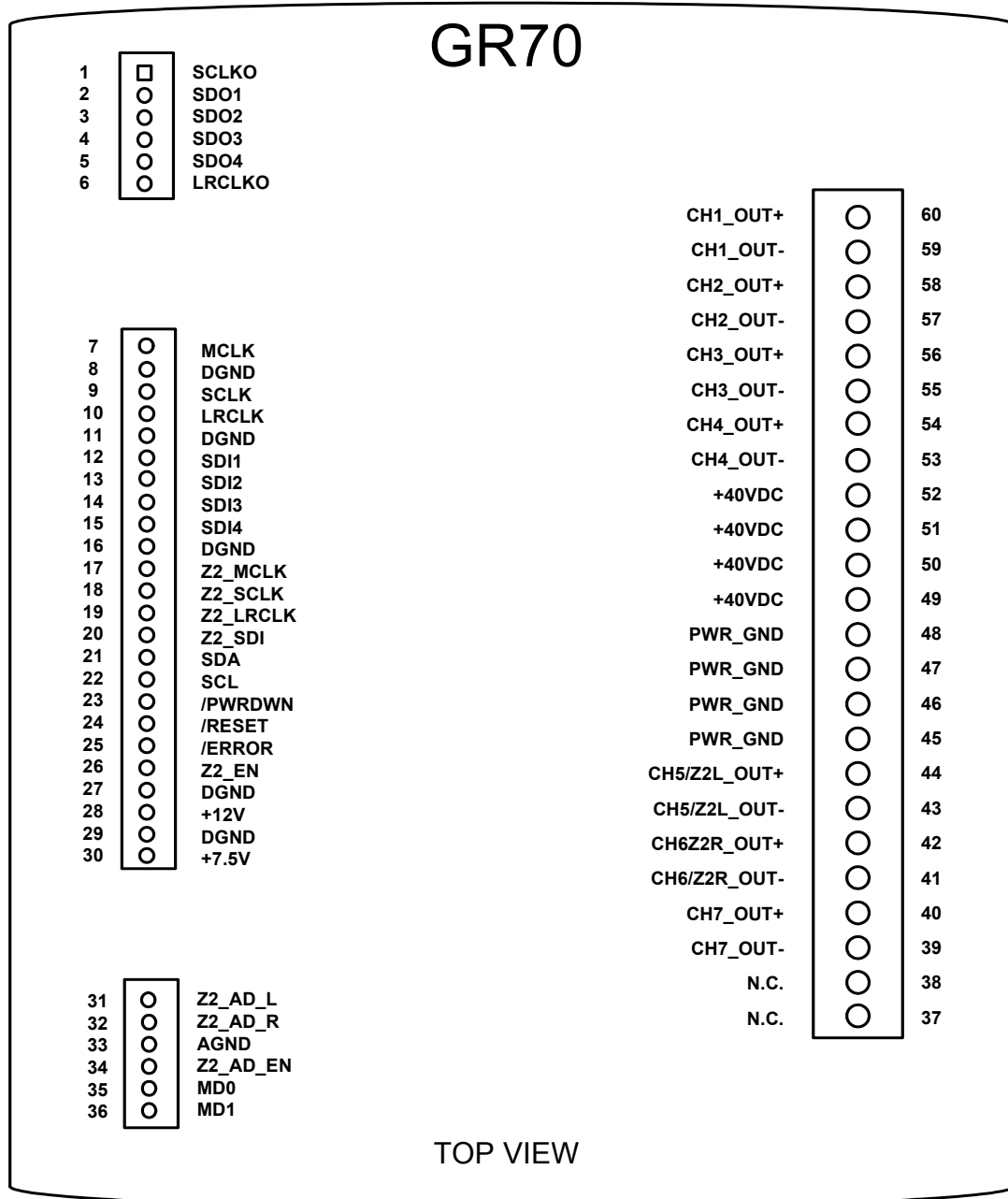

FIGURE 5: THD+N vs. Power

4 MODULE PINOUT



4.1 PIN DESCRIPTIONS

Pin #	Pin Name	I/O	Description
1	SCLKO	O	Output Shift Clock
2	SDO1	O	Channel 1,2 I ² S Output Data
3	SDO2	O	Channel 3,4 I ² S Output Data
4	SDO3	O	Channel 5,6 I ² S Output Data
5	SDO4	O	Channel 7,8 I ² S Output Data
6	LRCLKO	O	Output Left / Right Clock
7	MCLK	I	Master System Clock
9	SCLK	I	Serial Data Shift Clock
10	LRCLK	I	Left / Right Clock
12	SDI1	I	Channel 1,2 I ² S Input Data
13	SDI2	I	Channel 3,4 I ² S Input Data
14	SDI3	I	Channel 5,6 I ² S Input Data
15	SDI4	I	Channel 7,8 I ² S Input Data
17	Z2_MCLK	I	Zone 2 Master System Clock
18	Z2_SCLK	I	Zone 2 Serial Data Shift Clock
19	Z2_LRCLK	I	Zone 2 Left / Right Clock
20	Z2_SDI	I	Zone 2 Channel 1,2 I ² S Input Data

TABLE 8: Digital Signal Pins

Pin #	Pin Name	I/O	Description
21	SDA	I/O	2-Wire Serial Control Interface Data and Address
22	SCL	I/O	2-Wire Serial Control Interface Clock
23	/PWRDWN	I	Amplifier Disable
24	/RESET	I	Amplifier Internal Reset
25	/ERROR	O	Amplifier Internal Error
26	Z2_EN	I	Zone 2 Enable
34	Z2_AD_EN	I	Zone 2 A/D Enable
35	MD0	I	Mode Control Enable 0
36	MD1	I	Mode Control Enable 1

TABLE 9: Control Signal Pins

Pin #	Pin Name	I/O	Description
37	NC	O	No Connection - make no external connection to this pin
38	NC	O	No Connection - make no external connection to this pin
39	CH7-	O	Channel 7 Minus Speaker Output
40	CH7+	O	Channel 7 Plus Speaker Output
41	CH6/Z2R-	O	Channel 6 or Zone 2 Right Minus Speaker Output
42	CH6/Z2R+	O	Channel 6 or Zone 2 Right Plus Speaker Output
43	CH5/Z2L-	O	Channel 5 or Zone 2 Left Minus Speaker Output
44	CH5/Z2L+	O	Channel 5 or Zone 2 Left Plus Speaker Output
53	CH4-	O	Channel 4 Minus Speaker Output
54	CH4+	O	Channel 4 Plus Speaker Output
55	CH3-	O	Channel 3 Minus Speaker Output
56	CH3+	O	Channel 3 Plus Speaker Output

TABLE 10: Speaker Output Pins

Pin #	Pin Name	I/O	Description
57	CH2-	O	Channel 2 Minus Speaker Output
58	CH2+	O	Channel 2 Plus Speaker Output
59	CH1-	O	Channel 1 Minus Speaker Output
60	CH1+	O	Channel 1 Plus Speaker Output

TABLE 10: Speaker Output Pins

Pin #	Pin Name	I/O	Description
8, 11, 16, 27	DGND		Digital Ground
45, 46, 47, 48	PWR_GND		Output Stage Ground
33	AGND		Analog Ground
49, 50, 51, 52	HV		+38 VDC High Voltage Power
28	+12VDC		+12 VDC Power
30	+7.5VDC		+7.5 VDC Power

TABLE 11: Power Supply Pins

Pin #	Pin Name	I/O	Description
31	Z2_AD_L	I	Zone 2 Analog Left
32	Z2_AD_R	I	Zone 2 Analog Right

TABLE 12: Analog Inputs

4.2 PIN DEFINITION

4.2.1 ZONE 2 ANALOG INPUTS

Z2_AD_R,L **Zone 2 Analog Inputs**

This is the Zone 2 analog input. The Z2_AD_R,L are independent analog inputs for the second audio zone. The inputs are selected when the amplifier is configured for Mode 2 and the Z2_AD input is Set High. See Chapter 5 for additional information. The A/D convertor is fixed at a 48kHz sample rate with a 2.0V rms input level.

4.2.2 DIGITAL AUDIO INPUTS

MCLK **Master System Clock**

This pin is the master clock input for the primary channels on SDI[4:1]. The master clock must be an integer multiple of the LRCLK frequency. The default master clock is 12.288 MHz which corresponds to a 48 kHz sample rate (F_s) * 256. The MCLK is a 3.3 volt input.

LRCLK **Left/Right Clock**

This pin is the framing clock for the primary channels on SDI[4:1]. The serial input data is transmitted as two channels every sample rate period. The LRCLK determines the start of each data pair. The LRCLK frequency determines the input sample rate (F_s). The LRCLK is a 3.3 volt input.

SCLK **Shift Clock**

This pin is the Shift Clock input for the primary channels on SDI[4:1]. The serial clock is used to frame each input bit of the serial input data. The shift clock frequency is typically $64 \cdot F_s$. The SCLK is a 3.3 volt input.

SDI[4:1] **Serial Data Input**

These pins are the Serial Data input for the primary channels. Serial Data is arranged as four left/right inputs. The input format options are I²S, Left Justified, and Right Justified. 16, 18, 20, and 24 bit data lengths are available. The SDI pins are 3.3 volt inputs. Note that input channel 8 is not used.

Channel	SDI Input	Left or Right
1	1	Left

TABLE 13: SDI Input to Channel Mapping

2	1	Right
3	2	Left
4	2	Right
5	3	Left
6	3	Right
7	4	Left
8	4	Right

TABLE 13: SDI Input to Channel Mapping (Continued)

4.2.3 ZONE 2 DIGITAL INPUTS

Z2_MCLK

Zone 2 Master System Clock

This pin is the master clock input for Zone 2. The master clock must be an integer multiple of the Z2_LRCLK frequency. The default master clock is 12.288 MHz which corresponds to a 48 kHz sample rate (F_s) * 256. Z2_MCLK is required if the second zone featured is enabled. The Z2_MCLK is a 3.3 volt input.

Z2_LRCLK

Zone 2 Left/Right Clock

This pin is the framing clock of the serial data input for Zone 2. The serial input data is transmitted as two channels every sample rate period. The Z2_LRCLK determines the start of each data pair. The Z2_LRCLK frequency determines the input sample rate (F_s). The Z2_LRCLK is a 3.3 volt input.

Z2_SCLK

Zone 2 Shift Clock

This pin is the Shift Clock input for Zone 2. The serial clock is used to frame each input bit of the serial input data. The shift clock frequency is typically $64 * F_s$. The Z2_SCLK is a 3.3 volt input.

Z2_SDI

Zone 2 Serial Data Input

This pin is the Serial Data input for Zone 2. Serial Digital Data is arranged as a single left/right input. The input format options are I²S, Left Justified, and Right Justified. 16, 18, 20, and 24 bit data lengths are available. The Z2_SDI is a 3.3 volt input.

Channel	ZONE 2 SDI Input	Left or Right
1	1	Left
2	1	Right

TABLE 14: Z2_SDI Input to Channel Mapping

4.2.4 DIGITAL AUDIO OUTPUTS

LRCLKO

Output Left/Right Clock

This pin is the framing clock for the serial data for the primary channels on SDO[4:1]. The serial output data is transmitted as two channels every sample rate period. The LRCLKO determines the start of each data pair. The LRCLKO frequency determines the input sample rate (F_s). The LRCLKO is a 3.3 volt output.

SCLKO

Output Shift Clock

This pin is the Shift Clock output for the primary channels on SDO[4:1]. The serial clock is used to frame each input bit of the serial output data. The shift clock frequency is typically $64 * F_s$. The SCLKO is a 3.3 volt output.

SDO[4:1]

Serial Data Output

These pins provide the Serial Data Output for primary Channels. Serial Data is arranged as four left/right outputs. The SDO is a 3.3 volt output. Note that although input channel 8 does not map to a speaker output, the results of processing channel 8 may be output on SDO[4].

Channel	SDO Outputs	Left or Right
1	1	Left
2	1	Right
3	2	Left

TABLE 15: SDO Output to Channel Mapping

4	2	Right
5	3	Left
6	3	Right
7	4	Left
8	4	Right

TABLE 15: SDO Output to Channel Mapping

4.2.5 CONTROL INPUTS

SDA Serial Control Data and Address

This pin is the bidirectional Serial Data and Address line for the 2-wire serial control interface. The pin is pulled internally high to 3.3 volts via a 10 k Ω resistor.

SCL Serial Control Clock

This pin is the bidirectional Serial Clock line of the 2-wire serial control interface. The pin is pulled internally high to 3.3 volts via a 10 k Ω resistor.

/RESET Reset

This pin is the reset input to the module. Driving the reset to active low for 10 ms will bring all internal devices to their default state. This is a 3.3 volt input with an internal 10 k Ω resistor to ground. During the power on sequence, the reset line must be low during the high voltage supply ramp period. It must be held low for a minimum of 500ms after the supply reaches 95% of its nominal value.

/PWRDWN Amplifier Power Down

This pin is the amplifier power down input. When set high, the amplifier controller is placed in its active state. When pulled low, the amplifier starts a power down sequence. All outputs are soft muted and the output stages are disabled. Internal register values are maintained during the power down state. This is a 3.3 volt input with an internal 10 k Ω resistor to ground.

4.2.6 CONTROL OUTPUTS

/ERROR Amplifier Error

The /ERROR signal is an open-collector output with internal 10k ohm pullup to +3.3V. When low, /ERROR indicates that a fault condition has occurred in the amplifier, or the amplifier is powered down. Fault conditions include over-temperature, over-current, short circuit, and power output power stage disabled. When the module is issued a reset, the output stage will be disabled. The error signal will remain active low until the EAPD (External Amplifier Power Down) bit is set in the appropriate controller register.

4.2.7 ZONE 2 CONTROL SIGNAL INPUTS

Z2_EN Zone 2 Enable

This pin is the Zone 2 enable. When set active high, the second zone feature is activated. Amplifier channels five and six are configured as an independent second zone. The second zone input source may be either the Zone 2 digital I²S input port or the Zone 2 analog stereo input. This is a 3.3 volt input with an internal 10 k Ω resistor to ground.

Z2_AD_EN Zone 2 Analog Enable

This pin is the Zone 2 analog input enable. When set active high, the Zone 2 analog input is selected. When set clear low, the Zone 2 digital I²S input port is active. This is a 3.3 volt input with an internal 10 k Ω resistor to ground.

MD[1,0] Mode Configuration

These pins are the Mode access inputs. The Mode access inputs allow the primary and second zone configuration to be separately controlled. See Chapter 5 for additional detail on the use of the MD1 and MD0 inputs. The following table describes how the Z2_EN and Mode inputs affect the operating configuration.

Z2_EN	MD[1,0]	Configuration Access
x	11	Global control access

Table 16: MD Input Control of Configuration Access

Z2_EN	MD[1,0]	Configuration Access
1	10	Only second zone control
1	01	Only primary zone control
x	00	Illegal

Table 16: MD Input Control of Configuration Access

4.2.8 SPEAKER OUTPUTS

CH[7:1]+,-

Speaker Channel Outputs

These pins provide the Power Amplifier Outputs. Each channel of the amplifier is a full-bridge output configuration. Each channel consists of a plus (+) and minus (-) output. The outputs must remain floating and must not be connected to ground. Amplifier channels may be paralleled for additional power output into lower impedance speakers. For example two output stages may be paralleled (plus to plus, minus to minus) to deliver 140 Watts into 4Ω. When paralleled, the plus and minus outputs must never be connected together or to ground and the input and volume controls must be set correctly.

5 AMPLIFIER OPERATION

5.1 OPERATING MODES

The GR70 amplifier module with the second zone option may be operated in a seven channel configuration or a dual zone configuration. The dual zone configuration has 5 primary channels and a 2 channel (stereo) second zone. The Z2_EN input selects the configuration, when high the dual zone operation is selected.

In the seven channel configuration, all seven amplifier outputs are assigned to the primary channels. Zone 2 is disabled. All input sources are the I²S digital inputs (SDI[4:1]). The audio channel data is also available on the digital output port (SDO[4:1]).

In dual zone configuration, five audio channels are assigned to the primary channels with two channels for the second zone. The amplifier primary channel outputs are assigned to digital audio inputs, SDI[4,2,1]. Amplifier outputs five and six are assigned as a second zone, Zone 2. Two audio input sources are available for driving this second zone amplifier output, analog audio inputs Z2_AD_R,L or the Zone 2 Serial Data input, Z2_SDI. The selection of analog or digital input is controlled by the state of Z2_AD_EN. When Zone 2 is enabled, input and output channels are mapped to channels five and six. The Zone 2 speaker outputs are on CH5/Z2L_OUT and CH6/Z2R_OUT.

The primary channels remain on the digital outputs, SDO[4,2,1], but the Zone 2 channels are not available on the digital audio output.

The following table summarizes the input to output channel mapping.

Z2_EN	Z2_AD_EN	Primary Input	Zone 2 Input	Output CH1-4,7	Output CH5,6
0	0	SDI[4:1]	Disabled	Primary	Primary
1	0	SDI[4,2,1]	Digital	Primary	Zone 2
1	1	SDI[4,2,1]	Analog	Primary	Zone 2

TABLE 17: Amplifier Channel Mapping

5.2 ZONE 2 CONFIGURATION

The MD0 and MD1 inputs provide for independent operation of the speaker outputs when in dual zone configuration. The use of MD0 and MD1 are configuration register specific and may cause undesirable operation of the GR70 if used outside of the described procedures. Table 18 lists a definition of terms used in the Zone 2 Configuration.

Term	MD0,MD1,Z2_AD_EN,Z2_EN Configuration Pins	Control Register
SET	High Level Voltage (3.3V)	Logic 1
CLEAR(ED)	Low Level Voltage (0V)	Logic 0

TABLE 18: Definition of Terms

5.3 ACTIVATING THE AMPLIFIER

The GR70 does not maintain control register settings when power is off. After reset the GR70 amplifier is in a passive state, all registers are in their reset state, which results in the outputs being muted.

The following procedure activates the amplifier:

- SET MD0 and MD1
- To activate the output stages, SET the EAPD bit in the *ConfF register 05H*.
- The MPC bit in *ConfA register 00H* must be CLEARED for normal operation of the amplifier.
- Configure individual volume controls, mutes, and master volume registers as needed.
- MD0 and MD1 must remain SET for normal amplifier operation.

5.4 POWER DOWN AND POWER OFF

The PowerDown state is the condition where the supplies are at their nominal level, but the amplifier is inactive due to the assertion of either /RESET or /PWRDWN. Chapters 13.3 through 13.5 describe PowerDown operation. To avoid output pops, the /RESET input should not be used to transition from the active state to the PowerDown state.

PowerOff is the condition where one or more power supply is off. When transitioning from PowerOff to the condition where all power supplies are at their nominal level, /RESET should be active. This insures that the amplifier initializes properly with no output pops. When transitioning from active operation to PowerOff, put it in the PowerDown state or clear the EAPD bit in the *ConfF register 05H*. From the PowerDown state (or EAPD low) the power supplies can be turned off without speaker output pops.

5.5 ENABLING ZONE 2

When enabling or disabling the second zone, the following procedure is used:

- SET MD1 and MD0.
- SET master mute bit, MMute, in Mmute register 06H.
- Power down the amplifier output stages, CLEAR EAPD bit in *ConfF register 05H*.
- CLEAR MD1 and SET Z2_EN.
- If the zone 2 input is analog, enable zone 2 analog input, SET Z2_AD_EN. The input format must also be configured for I²S with a 48kHz sample rate.
- Configure the digital input format and sample rate using *ConfA register 00h* and *ConfB register 01H*. Access to any other registers will result in undesired operation. The Zone 2 outputs, CH5_OUT and CH6_OUT, are now assigned to input channels Five and Six.
- Program all parameters for zone 2 - EQ, volume, etc.
- SET MD1
- Restore the amplifier output stages: SET EAPD bit in *ConfF register 05H* and CLEAR the MMute bit in *Mmute register 06H*.

The amplifier is now ready for operation in the dual zone configuration.

5.6 SAMPLE RATE CHANGE WITH ZONE 2 ENABLED

The sample rate of the primary channels may be modified without disturbing the operation of Zone 2. This will be required when switching between 44.1-48kHz, 96kHz, or 192kHz. Follow this procedure:

- Mute channels 1 through 4 and 7: SET bits C1M through C4M and C7M in *Channel Mute register 08H*.
- CLEAR MD0.
- Power down the primary amplifier output stages: CLEAR EAPD bit in *ConfF register 05H*.
- Configure the primary sample rate and digital input format using *ConfA register 00h* and *ConfB register 01H*. Access to any other registers will result in undesired operation.
- SET MD0.
- Restore the amplifier output stages: SET EAPD bit in *ConfF register 05H* and CLEAR bits C1M through C4M, CM7 in *Channel Mute register 08H*.

The amplifier is now ready for operation.

5.7 HEADPHONE OPERATION WITH ZONE 2 ENABLED

The amplifier digital outputs may be used to drive headphones via an external DAC. The speaker outputs of the primary output channels can be muted for headphone only operation without disturbing the operation of Zone 2. The procedure is:

- CLEAR MD0.
- Power down the primary amplifier output stages, CLEAR EAPD bit in *ConfF register 05H*.
- SET MD0.

To restore the primary output channels:

- CLEAR MD0
- SET EAPD bit in *ConfF register 05H*.

- SET MDO

5.8 POWER SUPPLY AND POWER ON RESET

During the power on sequence, the reset line must be active during the high voltage supply ramp period. It must be held for a minimum of 500ms after the supply reaches 95% of its nominal value. The power on rise time of the 46V Power supply MUST NOT exceed a rise time rate faster than 20V / second. The figure below illustrates the reset timing with power ramp.

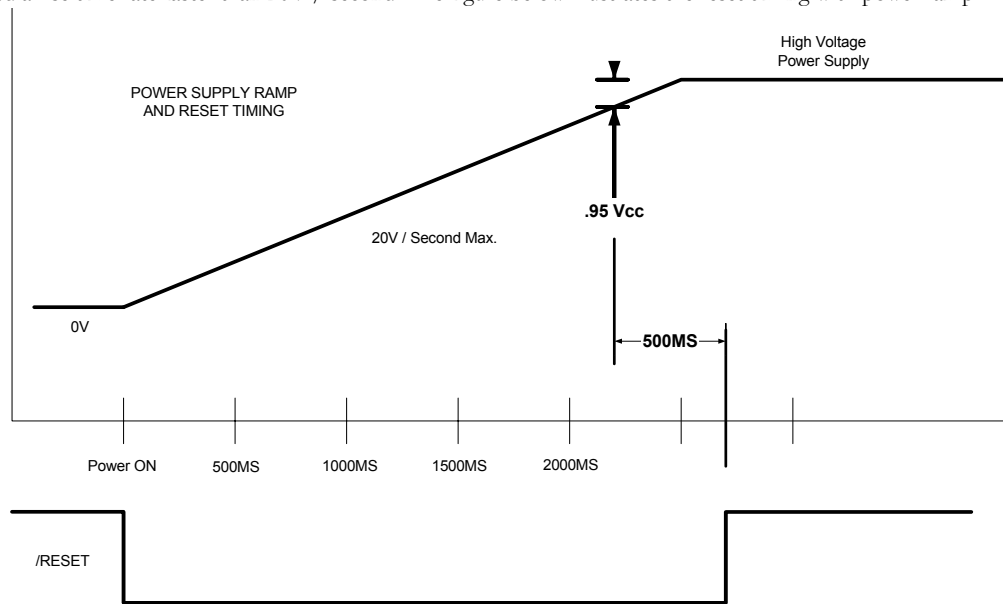

5.9 POWER SUPPLY SEQUENCING

Normal device operation expects the high voltage supply to come up first, with the others following as the regulators activate. The supplies may be turned on and off in any order without harming the amplifier, however the attached speakers may be damaged by the transients if the amplifier is not muted. Normal device operation expects the the high voltage supply to decay first, then the other decay as the regulators drop out.

5.10 OPERATIONAL LIMITATIONS

Do not generate audio output greater than 20kHz with no load. Peaking in the output filter can cause the output voltages to exceed the filter capacitor voltage rating. Normal audio program material will not have enough energy to cause problems. Avoid test tones above 20kHz.

5.11 AMPLIFIER OVERLOAD PROTECTION

The amplifier monitors drive currents in each power MOSFET and the heat sink temperature. The current sensors protect the output stage from over-current and short-circuit faults. The temperature sensor protects the amplifier from excessive operating temperature. The protection features only affect the speaker output stages. The configuration and register settings are not altered by amplifier protection actions.

Short duration over-current events, such as produced by a loud program passage or momentary speaker terminal short, will cause the individual output stage to current limit. The /ERROR output will not report a short duration over-current. Longer duration over-current events, greater than 250ms, will shut down all speaker output channels and the /ERROR output will be active low. In a dual zone application, both zones are shut down by a long duration over-current.

Recovery from an over-current shut down is automatic. Approximately 500ms after the over-current shut down, the speaker outputs will activate. If the condition that caused the shut down persists, the amplifier will shut down in approximately 250ms.

At approximately 100 degrees C, the amplifier will shut down all output channels and the /ERROR output will be driven active low indicating an over-temperature fault. In a dual zone application, both zones are shut down by an over-temperature condition.

Recovery from an over-temperature shut down is automatic. When the amplifier cools to approximately 80 degrees C, the speaker outputs will activate.

When the amplifier is reset (/RESET input low), or powered down (/PWRDWN low), the /ERROR output will be active low. This provides an indication that the amplifier is in the reset or power down condition.

DPR1005 MECHANICAL PARTS LIST

REF NO.	PARTS NO.	DESCRIPTION	TYPE
	3SA-3150US-BC00-1-1	AC MECH BOM DPR1005 HARMAN OEM	
	H01-ZVD03DWT434-7	TAPE AL PANEL DOOR	
	H01-ZMB01S00100-5	BKT HEADPHONE JACK	
	H01-ZMC12S19A00-2	BKT AC INLET	
	H01-ZMC12S20A00-2	BADGE AL HARMAN/KARDON SILVER	
	H01-ZMD03MAGN00-2	MAGNET	
	H01-ZMD03S00200-6	AL DOOR	
	H01-ZMD03S05A00-8	BRACKET MAGNET LEFT	
	H01-ZMB01S02200-9	SPRING PLATE GND C5212 0.2T	
	H01-ZMD03S05AYE-6	STUD STANDOFF HEX M4X0.7 6X27.5H	
	H01-ZMD03S03AYE-4	STUD-1 H34MM	
	H01-ZMD03S04A00-7	BKT HINGE	
	H01-ZMD03S07A00-A	FRONT CHASSIS	
	H01-ZMD03S08A00-0	COVER TOP	
	ZSTPM2006BZ-9	SCREW S-TPG,WASHER 4.8MM,2.0X6,ZI-PLATED	
	ZSTWM3A08BY-6	SCREW ST W7.5PH 3X8	
	H01-ZMD03S13A00-4	MAIN CHASSIS	
	ZFNR10803GY-1	DOOR RUBBER	
	H01-ZMD03S00300-8	AL PANEL DOOR	
	H01-ZMD03S11A00-2	PANEL REAR DPR1005	
	H01-ZPC1018GART-7	FILTER VFD	
	H01-ZMGEN00GAGY-0	AL LOGO BADGE TOP	
	H01-ZPD0301GASG-A	BUTTON DUMMY -1	
	H01-ZPD0302GASG-8	BUTTON DUMMY -2	
	H01-ZPD0303GASG-6	BUTTON DUMMY -3	
	H01-ZPD0304GASG-4	BUTTON DUMMY-4	
	H01-ZPD0305GASG-2	BUTTON DUMMY-5	
	H01-ZPD0306GAGY-3	BUTTON 1 KEY	
	H01-ZPD0307GAGY-1	BUTTON 4KEY	
	H01-ZPD0308GAGY-A	BUTTON 3KEY-B	
	H01-ZPD0309GAGY-8	BUTTON 5KEY	
	H01-ZPD0310GAGY-3	BUTTON 3 KEY-A	
	H01-ZPD0320GABK-8	DOOR HINGE-LEFT	
	H01-ZPD0313GAGY-8	MAGNET CASE	
	H01-ZPD0314GAMW-5	STANBY INDICATOR	
	H01-ZPD0315GAMW-3	VOLUMN KNOB	
	H01-ZPD0316GASG-A	COVER KNOB	
	H01-ZPD0317GACR-4	CAP KNOB VOLUMN	
	H01-ZPD0312GAGY-A	PANEL FRONT DPR1005	
	H01-ZPD0319GABT-5	WINDOW DISPLAY DPR1005	
	H01-ZVD03GEAR01-5	DAMPER GEAR DP102	
	H01-ZVD03TUNE00-9	TUNER MODULE KST-MV014MA	
	ZFNR19720SB-5	RUBBER FOOT 19.7X19.7X2T BK	
	ZKCL222HA00-2	LABEL RISK	
	ZKCL229HA00-7	LABEL DATE	
	ZKGEN29HA00-8	LABEL DATE BLANK	
	ZKCL281HA00-9	LABEL QC CHECK	
	ZKDO330HA00-9	LABEL SERIAL DPR1005	
	ZKDO373HA00-A	LABEL BARCODE DPR1005	
	ZKDO395HA00-3	LABLE LICENSE DPR1005	
	ZPD0303GAGY-8	BUTTON POWER	
	ZFNRB228700-8	POWER RUBBER	
	ZPC1103GAGY-A	FOOT 50MM 15.8MM	
	ZSMWM4008BZ-2	SCREW M.S M4X8 W/H ZN PLATED	
	ZSTM3010BB-3	SCREW ST BH 3X10 GROUND	
	ZSTBM3010BB-5	SCREW ST BH 3X10	
	ZSTWM3008BY-8	SCREW ST WPH 3X8	
	ZSTWM4008BC-3	SCREW ST WPH 4X8 SILVER CHROM	
	H01-ZPD0321GABK-6	DOOR HINGE-RIGHT	
	ZTB017030AA-4	CABLE TIE 100MM NYLON 6	
	ZUC1201AABK-7	SPONGE 30X30X10T BK	
	H01-ZVD03S01300-8	ASS'Y SMPS KJP-05013 70W	
	H01-ZPD0318GAMW-8	INDICATOR VIDEO	
	H01-ZMD03S02A00-5	BRACKET MIDDLE	
	H01-ZMD04S12A00-1	SHIELD TUNER DPR2005	
	H01-FBD0480BR00-2	FCORE CLAMP FILTER LF80BR W5 SRH 16X28X9	
	ZUD040916BK-A	SPONGE VOLUMN	
	H01-ZMD03S05B00-A	BRACKET MAGNET RIGHT	
	H01-ZMD03S03A00-6	BRACKET JACK	
	H01-WF13S1405FU-0	WIRE FFC CABLE DHCDF-13/140-P1.25-BT	
	H01-WF17S4505FU-5	WIRE FFC CABLE DHCDF-17/450-P1.25BT	
	H01-WG03SH83300-6	WIRE ASS'Y 6.2MM 3P 330MM UL1015#14 BLK	
	ZSTFM0306BN-2	SCREW S.T 3X6 F/H NI PLATED	
	ZUC1203AABK-A	SPONGE 15X30X8T BK	
	ZKGEN97HA00-3	LABEL MAIN POWER REMIND	
	XY1N250M0CL-5	GLUE, TRANSPARENT, CANDY STRIP, W=12MM, L=50M @M	
	H01-ZMD03S04AYE-5	STUD-3 H 11MM	
	H01-WG10SD83820-9	WIRE ASS'Y 2.5MM 10P 380MM UL1007#20 STR RED	
	XY1N033M0DW-3	DOUBLE SIDE TAPE #Y-4615 (3M)	
	H01-ZUD0301AABK-A	SPONGE-UL 30X30X12T BK DPR2005	
	ZSTBM3006BB-7	SCREW ST BH 3X6MM	
	ZQB0101AA00-4	SHIELD FOAM GASKET (WOORI)	

DPR1005 MECHANICAL PARTS LIST

DPR1005 ELECTRICAL PARTS LIST

REF NO.	PARTS NO.	DESCRIPTION	TYPE
	ZSMWM3008BZ-7	SCREW M.S M3X8 W/H ZN PLATED	
	ZSTWM3006BY-1	SCREW S.T 3X6 W/H YELLOW ZINC PLATED	
	ZWF793008PO-5	WASHER FIBER 3 0.8T	
	ZSTFM0308BN-9	SCREW S.T 3X8 F/H NI PLATED	
	H01-ZMD03S21A00-0	BKT SHIELD AMP DPR2005	
	H01-FBB0102AA00-7	FCORE FERRIT MAGNET SRH9. 9X20. 0X5. 1+CASE W5	
	XY1N218M3SW-4	GLUE FURROW W=12MML=18.3M SS WHITE @ROLL	
	XYDET00K500-6	DETERSIVE,N.W=0.5KG @BOTTL	
	XYVAS00K500-6	VASOGEN,YELLOW,N.W=0.5KG @BOTTL	
	XYALC01G000-2	ALCOHOL V=1.0GALLON @GALLON	
	XYGLAA5K200-3	GLASS CLEANER,N.W=0.52KG @BOTTL	
	XYKIFA4L500-1	KIF VEG LIQUID CAR WAX,V=0.445 L @BOTTLE	
	XY501110CRD-2	GLUE, RED #AK-501 F/SCREW V=110CC @BOTTL	
	XY1N250M0DW-4	GLUE,TAPE,#9070,W=12MM,L=50,DOUBLE-SIDE,WHITE. @METER	
	XY1P202K000-1	WIRE, TIN, D=1.2MM N.W=2.0KG @KG	
	XY57501K0YW-0	GLUE, YELLOW, N.W=1.0KG #575 @KG	
	XY1M3000000-6	MEMBRANE POLY TRANS W=1.3M @ROLL	
	XYEM501K000-2	SPECIALTY LUBRICANTS GREASE,#EM-50L,W=1KG @G	
	ZWM803305PZ-1	WASHER PLAIN 3	
	XY2N450M0DW-6	GLUE,TAPE,#9070,W=24MM,L=50,DOUBLE-SIDE,WHITE. @METER	
	3SA-3150US-FCMI-1-5	AC EMBD IMA FRONT BD DPR1005	
	3SA-3151US-FCAA-1-0	AC ESABD IAA FRONT BD DPR2005	
R906 907	RC3DI0471IN-0	RCF 470R0 OHM +5% 250MI0W	
L800 901	H01-LAINB0470CR-2	LF 47U0H +10% 5.8 OHM 500MI0A	
	PBD07KFCI20-A	PCB SINGLE FRONT DPR2005 397MM*163MM*1.6t FR-4	
R941 942	RC3DI010AIN-1	RCF 1R0 OHM +5% 250MI0W	
L900	H01-LAINB047ACR-3	LF 4U7H +10% 1.7 OHM 190.0A	
C803 907 501 502 503 504	CCZID0104NA-2	CC 100N0F +80% -20% 50.0V F	
L911 912	H01-FB05B3580NN-1	BEAD AXIAL/TAP,HC3580 80.5ohm	
C505 506	CCKID0681NN-3	CC 680P0F +10% -10% 50.0V 2B4	
3SA-3150US-PA00-1-0		AC PKG BOM DPR1005	
	BTA3A1511SF-0	BATTERY ALKALINE 1.5V AAA	
	H01-ATLLF0146BY-A	ANTENNA LOOP SO146BY-100	
	H01-RYCI202HA00-5	REMOCON ZONE 2	
	H01-RYD0301HA00-4	REMOCON DPR1005	
	H01-WAB01200203-9	ANTENNA WIRE 75 CT02-FM 0 0	
	ZBP00122051-8	BAG PE 330 X245 T0.05	
	ZHC1201AAWH-A	FILM SHEET PE 920 X 1000	
	ZKC1113HA00-9	CARD WARRANTY	
	XY1N218M3CL-9	GLUE TRANSPARENT W=12MM L=18.3M @ROLL	
	ZKC11H96A00-1	POLISHING CLOTH	
	ZKC1214HA00-A	LABEL SAFETY LEAFLET	
	ZKCL270HA00-7	LABEL "PLEASE"	
	ZKDO301HA00-9	USER MANUAL DPR1005	
	ZKDO304HA00-8	BOX CARTON DPR1005	
	ZKDO352HA00-2	QUICK SETUP GUIDE DPR1005	
	ZKDO373HA00-A	LABEL BARCODE DPR1005	
	ZKGEN56HA00-5	ENVELOPE POLISHING CLOTH	
	ZQD0301HA00-A	CUSHION POLY (EPS)	
	H01-WAUSA2103BK-1	POWER CORD WS-004C+002E SJT#14*2C L=2M	
	ZBP00020350-4	POLYBAG BATTERY	
	XY7N636M5CL-8	Glue, Transparent,W=76mm, L=36.5m @m	
	XYJBLA4L800-5	WAX JUBILEE, CLEANER V=0.48LITER @BOTTLE	
	XYGLAA5K200-3	GLASS CLEANER,N.W=0.52KG @BOTTL	
	XY0M51K5M00-3	MEMBRANE POLY TRANS W=0.5M L=1.5KM @ROLL	
3SA-3150US-AMMI-1-9		AC EMBD IMA AMP BD DPR1005	
	PBD04KAMB20-A	PCB DUAL DPR2005 AMP 233.9MM*219MM *1.6t FR-4	
AMP1	H01-ZVD03007000-A	ASS'Y AMP MODULE GR0070-7 70W	
C16 18 19 21	H01-CEMJA0228AH-3	CAP ELEC 2200UF 63V M SHL SAMYOUNG	
C37	H01-CEHJA0477MN-5	CE 470U0F M 63.0V 12.5X20 SHL	
P4	H01-WN06AB00001-4	CNT PLUG BD'BD SOCKET 2.0mm 35237-0610	
L1	H01-LCNN18190NA-4	COIL CHOKE 190UH TOROIDAL	
P6 7	H01-WN11AB00000-0	CONN 2.0MM 11 MA R NAT SOCKET MOLEX 35237-1110 0 0	
P3	H01-WN02SB00000-9	CONN 2.0MM 2 MA ST NAT GT201-2P-TS	
P5	H01-WN03SB00000-6	CONN 2.0MM 3 MA ST NAT GT201-3P-TS	
NJ3	H01-SOPA619BKNN-7	CONN-SPE TERMINAL SPKR 6P SH0611708P FE 19MM 6 BK 0 0	
NJ2	H01-SOPA81900NN-8	CONN-SPE TERMINAL SPKR 8P SH081136JP FE 19MM 8 -- 0 0	
D6	H01-DSBAT0054NB-7	DIODE BAT54 SMALL SIGNAL SOT-23	
D2	H01-DRSB36060NA-1	DIODE SCHOTTKY SB360 60V 3A DO-201AD	
HS1	H01-ZMD04HS0400-4	HEATSINK AMP	
IC2	H01-ICLMO259307-1	IC POWER CONVERTER LM2593HVT-ADJ TA07B	
IC1	H03-ICKIA7808I2-8	IC VOLTAGE REGULATOR KIA7808AP TO-220AB	
SH1	H01-ZMD03S20A00-A	SHIELD VIDEO	
N2	H01-WG08SE84600-1	WIRE ASS'Y UL1007#16 STR 460mm 3.96mm 8P RED	
N1	H01-WG02SD85300-4	WIRE ASS'Y UL1007#24 STR 530mm 2.5mm 2P GRY	
3SA-3150US-AMAR-1-9		AC ESABD IAR AMP BD DPR1005	
D1 3 4 5 7	H01-DR1N04004NA-1	D-SR 1N4004 400.0V 1.0A	
D8	H01-DR1N05819NA-6	DIODE SCHOTTKY RECTION 1N5819 40V 1A DO-41	
3SA-3151US-AMAR-1-6		AC ESABD IAR AMP BD DPR1005	

REF NO.	PARTS NO.	DESCRIPTION	TYPE
C42	CEHFC01075E-1	CE 100UF +20% 16.0V D6.3XL11 P5MM 85C	
C30 39	CEMFC0227NN-7	CAP ELEC 220UF 16V M5X11 ELITE	
C40	H01-CEMGA0108AH-1	CE KMG 1000UIOF M 25V 10X20 105C +-20%	
	3SA-3151US-AMST-1-2	AC ESABD SMD AMP BD DPR1005	
C22 23 24 25 28 29 32 33 34 35 36 43 48 49 50	CZZFI0104BF-8	CAP CHIP 100NOF +80% -20% 16.0V Y5V 0603	
C15 17 20 31	CZIKI0104DC-3	CAP CHIP 100NF 100V X7R 10% 1206	
C38	CZKII0332BC-1	CAP CHIP 3N3F +10% -10% 50.0V X7R 0603	
C1 10 11 12 13 14 2 3 4 5 6 7 8 9	CZIKI0471DC-9	CAP CHIP 470PF 100V X7R 10% 1206	
B10 11 12 13	H01-FB2K52012NN-5	FBEAD SURFACE MT 2500OHM FCM2012H-252T02	
L2 6	H01-FB3002012NN-4	FBEAD SURFACE MT 300OHM FCM2012V-301T07	
R11 12 13 14	RS3CB0102NN-8	RES,CHIP,1K,1/8W,+/-5%,0805	
R20	RS3AD0103NA-1	RMGCFMIC 10K0 OHM +5% 62MI5W	
R4 5 8	RS3AD0102NA-3	RMGCFMIC 1K0 OHM +5% 62MI5W	
R1 2 19	RS3AD0432NA-4	RMGCFMIC 4K3 OHM +5% 62MI5W	
R7	RS3AD0472NA-3	RMGCFMIC 4K7 OHM +5% 62MI5W	
R10	RS3AD0511NA-8	RMGCFMIC 510R0 OHM +5% 62MI5W	
R9	RS3AD0822NA-2	RMGCFMIC 8K2 OHM +5% 62MI5W	
	3SA-3150US-AMMI-1-9	AC EMBD IMA DIGITAL-IN BD DPR1005	
N5	H01-WN05SB00000-0	CONN 2.0MM 5 MA ST NAT GT201-5P-TS	
NJ10 11	H01-SOTOR179LBA-0	D-LEM TORX-179L	
NJ12	H01-SOTOT179LBA-7	D-LEM TOTX-179L	
NJ55	SOPA96063NN-0	JACK D-SUB 9P 87204-6063 W/DUST COVER BK	
NJ8	H01-SORAIJ440CE-0	JACK RCA 1P PPJ-440CE	
NJ9	H01-SORA20130JN-9	JACK RCA 2P JB020130JN	
L11	H01-LF11030A2NA-4	TFPULSE TRANSFORMER 110UH FP-110 FERRIT MAGNET	
N3	H01-WSS261705EN-8	WIRE ASS'Y 13P 170MM UL1533/1007 #26 2.0MM RED SHIELD	
N4	H01-WS7261843EN-A	WIRE ASS'Y 7P 180MM UL1007/1533#26 BLK	
	3SA-3150US-AMAR-1-9	AC ESABD IAA DIGITAL-IN BD DPR1005	
L3 4 5	H01-LAINB0470CR-2	LF 47U0H +10% 5.8 OHM 500MI0A	
	3SA-3151US-AMAR-1-6	AC ESABD IAR DIGITAL-IN BD DPR1005	
C397 403 27 41	CEHFC01075E-1	CE 100UF +20% 16.0V D6.3XL11 P5MM 85C	
C392 393 394 395 401	CEHIC01055E-6	CE 1UF +20% 50V D5XL11 P5MM 85C	
	3SA-3151US-AMST-1-2	AC ESABD SMD DIGITAL-IN BD DPR1005	
C396 404 413 416 424 437	CZZFI0104BF-8	CAP CHIP 100NOF +80% -20% 16.0V Y5V 0603	
C46	CZEII0100BE-0	CCCFMIC 10P0F +0P5F -0P5F 50.0V NP0 0603	
IC47 49	H01-ICM74H04MD4-2	IC-LOGIC M74HCU04M1R INVERTER HCT	
IC43	H01-ICUPD4721D8-3	IC-SPECFUNC UPD4721 DRIVERS/RECEIVERS CMOS RS-232C	
R3	RS3AD0000NA-0	RMGCFMIC 0 OHM +0% 62MI5W	
R484 15 493	RS3AD0153NA-8	RES CHIP,15K 1/16W,+5%,0603.	
R422 425	RS3AD0101NA-5	RMGCFMIC 100R0 OHM +5% 62MI5W	
R16 17 420	RS3AD0100NA-7	RMGCFMIC 10R0 OHM +5% 62MI5W	
R483 487 6	RS3AD0122NA-8	RMGCFMIC 1K2 OHM +5% 62MI5W	
R392 393	RS3AD0472NA-3	RMGCFMIC 4K7 OHM +5% 62MI5W	
R423 426 429 442	RS3AD0561NA-4	RMGCFMIC 560R0 OHM +5% 62MI5W	
R424	RS3AD0621NA-1	RMGCFMIC 620R0 OHM +5% 62MI5W	
R428 432 439	RS3AD0750NA-1	RMGCFMIC 75R0 OHM +5% 62MI5W	
Q3 4 5	H01-TRDTC114YNI-5	TR-SSD DTC114YKA N 10K0 OHM 47K0 OHM	
	3SA-3150US-AMMI-1-9	AC EMBD IMA F-DIGITAL BD DPR1005	
P701	H01-WN03SB00000-6	CONN 2.0MM 3 MA ST NAT GT201-3P-TS	
NJ70	H01-SOTOR179LBA-0	D-LEM TORX-179L	
NJ71	H01-SORAIJE01NN-0	JACK RCA 1P JE010003MN GND OR	
NJ72	H01-SORAC5016NN-5	JACK S-VIDEO C50160272N	
BK71	H01-ZMD03S18A00-9	SHIELD DIGITAL	
FG96	H01-ZMB01S02200-9	SPRING PLATE GND C5212 0.2T	
N700	H01-WS5269805EN-A	WIRE ASS'Y UL1007/1533 #26 980MM 2.0MM 5P RED SHI	
	3SA-3150US-AMAR-1-9	AC ESABD IAA F-DIGITAL BD DPR1005	
L700	H01-LAINB0470CR-2	LF 47U0H +10% 5.8 OHM 500MI0A	
	3SA-3151US-AMAR-1-6	AC ESABD IAR DIGITAL-IN BD DPR1005	
C704	CEHFC01072S-9	CE 100UF +20% 16V D6.3XL7 P2.5MM 2000hours 85C	
	3SA-3151US-AMST-1-2	AC ESABD SMD DIGITAL-IN BD DPR1005	
C700	CZZFI0104BF-8	CAP CHIP 100NOF +80% -20% 16.0V Y5V 0603	
C47	CZZFI0104BF-8	CAP CHIP 100NOF +80% -20% 16.0V Y5V 0603	
C702 703	H03-DS05GBUSCNB-5	DIODE PG05GBUSC	
IC3	H01-ICM74H04MD4-2	IC-LOGIC M74HCU04M1R INVERTER HCT	
R21	RS3AD0221NA-6	RMGCFMIC 220R0 OHM +5% 62MI5W	
	3SA-3150US-FCMI-1	AC EMBD IMA FRONT BD DPR1005	
P900	PBD07KFCI20-A	PCB SINGLE FRONT DPR2005 397MM*163MM*1.6t FR-4	
D902 903 904 905	H01-WN17AI00000-8	CONNECTOR FFC 17P 1.25MM ANG SCB-1017-00-2	
DP90	H01-DL30B2015AA-A	D-LEM 30B3-20-15 GaN SUPER BLUE WATER CLEAR 15	
H901	H01-VDHCA18LL03-7	FL HCA-18LL03	
H901	ZPC1017GABK-6	HOLDER VFD AVR430/630	
RM90	H01-ICRPM6933NN-3	IC-REMOTE RPM6938-RSIP-A3 RECEIVER 38KHZ	
FG90 91 94 97	H01-ZMB01S02200-9	SPRING PLATE GND C5212 0.2T	
N900	H01-WG11SD84220-6	WIRE ASS'Y 11P 420MM UL1007#20 2.5MM STR	

REF NO.	PARTS NO.	DESCRIPTION	TYPE
N602	H01-WG03SB80700-6 3SA-3151US-FCAA-1	WIRE ASS'Y 2.0MM 3P 70MM UL1007#26 RED AC ESABD IAA FRONT BD DPR1005	
R906 907	RC3DI04711N-0	RCF 470R0 OHM +5% 250MI0W	
L901	H01-LAINB0470CR-2	LF 47U0H +10% 5.8 OHM 500MI0A	
R941 942	RC3DI010AIN-1	RCF 1R0 OHM +5% 250MI0W	
L900	H01-LAINB047ACR-3	LF 4U7H +10% 1.7 OHM 190.0A	
C907	CCZID0104NA-2	CC 100NOF +80% -20% 50.0V F	
L911 912	H03-FB05B3580NN-7 3SA-3151US-FCAR-1-2	BEAD AXIAL/TAP,HC3580 80.5ohm AC ESABD IAR FRONT BD DPR1005	
C911	CEHFC04765E-3	CE47UF +20% 16.0V D5XL11 P5MM 85C	
C900 901	CPIKC0473NN-0	CPF 47NOF +10% 100.0V	
S900 901 902 903 904 905 906 907 908 909 910 911 912 913 914 915 916 917 918 919	H01-SWP1280APS1-8	SWITCH TACH JTP1280AP	
Q901	H03-TRMPSA56YNA-0 3SA-3151US-FCST-1-9	TR-SLPLF MPSA56 Y P -500MI0A -300V AC ESABD SMD FRONT BD DPR1005	
C606 902 910 912 913	CZZFI0104BF-8	CAP CHIP 100NOF +80% -20% 16.0V Y5V 0603	
C908 909	CZZII0223BF-1	CAP CHIP 22NOF +80% -20% 50.0V Y5V 0603	
D603 604 919	H01-DSIS50094NB-A	D-SLP 1SS355 35.0V 225MI0A	
D918	H01-DSUDZ09V1NB-7	D-ZENER UDZS 9.1B 9.1V 200MI0W	
Q900 902 905	H01-TRDTC114YNI-5	TR-SSD DTC114YKA N 10K0 OHM 47K0 OHM	
R929 501	RS3AD0100NA-7	RMGCFMIC 10R0 OHM +5% 62MI5W	
R939 940	RS3AD0101NA-5	RMGCFMIC 100R0 OHM +5% 62MI5W	
R912 921 937	RS3AD0102NA-3	RMGCFMIC 1K0 OHM +5% 62MI5W	
R913 922	RS3AD0122NA-8	RMGCFMIC 1K2 OHM +5% 62MI5W	
R914 930	RS3AD0152NA-A	RMGCFMIC 1K5 OHM +5% 62MI5W	
R943	RS3AD0103NA-1	RMGCFMIC 10K0 OHM +5% 62MI5W	
R920 936	RS3AD0183NA-A	RMGCFMIC 18K0 OHM +5% 62MI5W	
R901 923 924	RS3AD0221NA-6	RMGCFMIC 220R0 OHM +5% 62MI5W	
R915 931	RS3AD0222NA-4	RMGCFMIC 2K2 OHM +5% 62MI5W	
R916 932	RS3AD0272NA-0	RMGCFMIC 2K7 OHM +5% 62MI5W	
R917 933	RS3AD0332NA-8	RMGCFMIC 3K3 OHM +5% 62MI5W	
R925 926	RS3AD0471NA-5	RMGCFMIC 470R0 OHM +5% 62MI5W	
R918 934	RS3AD0562NA-2	RMGCFMIC 5K6 OHM +5% 62MI5W	
Q904	H03-TRKTD1304ND-0	TR-SLPSWA KTD1304 N 20V 300MI0A SOT-23	
R910 911	RS3AD0683NA-1	RMGCFMIC 68K0 OHM +5% 62MI5W	
R919 935	RS3AD0822NA-2	RMGCFMIC 8K2 OHM +5% 62MI5W	
R902 903 904 905	RS3AD0000NA-0	RMGCFMIC 0 OHM +0% 62MI5W	
	3SA-3150US-FCAR-1-5	AC ESABD VID4 BD DPR1005	
C603 604 609 610	CZJII0101BE-2	CCCFMIC 100P0F +5% -5% 50.0V NP0 0603	
C605	CZJII0330BE-9	CCCFMIC 33P0F +5% -5% 50.0V NP0 0603	
D605	H01-DLRED3FRDBA-5	D-LEM RED/GREEN 3F RD RND CL	
NJ60	H01-SORA3W019NN-9	JACK RCA 3P JCO3W0191N	
C602 D601 602	RS3AD0000NA-0	RMGCFMIC 0 OHM +0% 62MI5W	
R610	RS3AD0122NA-8	RMGCFMIC 1K2 OHM +5% 62MI5W	
R602 603	RS3AD0391NA-3	RMGCFMIC 390R0 OHM +5% 62MI5W	
R600 601 608 609	RS3AD0471NA-5	RMGCFMIC 470R0 OHM +5% 62MI5W	
FG93	H01-ZMD03S19A00-A	SPRING-A PLATE	
Q600 601	H01-TRDTC114YNI-5	TR-SSD DTC114YKA N 10K0 OHM 47K0 OHM	
W601	H01-WC1220405C1-9	WIRE ASS'Y UL1007 #22 TC 40MM 1P BLK	
N601	H01-WSC264805EN-3	WIRE ASS'Y UL1007/1533 #26 480MM 2.0MM 13P RED SHIELD	
	3SA-3150US-FCAR-1-5	AC ESABD H/P BD DPR1005	
C800	CZZFI0104BF-8	CAP CHIP 100NOF +80% -20% 16.0V Y5V 0603	
C801 802	CZKII0222BC-8	CAP CHIP 2N2F +10% -10% 50.0V X7R 0603	
C803	CCZID0104NA-2	CC 100NOF +80% -20% 50.0V F	
D800 801	H01-DSIS50094NB-A	D-SLP 1SS355 35.0V 225MI0A	
NJ80	H01-SOSS9CKX3NN-9	JACK PHONE 6.35 H70980110S 9P BK	
L800	H01-LAINB0470CR-2	LF 47U0H +10% 5.8 OHM 500MI0A	
R800 801	RS3AD022ANA-7	RMGCFMIC 2R2 OHM +5% 62MI5W	
FG81	H01-ZMB01S02200-9	SPRING PLATE GND C5212 0.2T	
N800	H01-WS4265805FN-A	WIRE ASS'Y UL1007/2547 #26 580MM 2.0MM 4P RED	
	3SA-3150US-FCAR-1-5	AC ESABD ENCODER BD DPR1005	
C600 601	CZKII0821BC-8	CAP CHIP 820P0F +10% -10% 50.0V X7R 0603	
VR60	H01-SWE3A0505S1-9	SWIROT EC16B24204 5V 500U0A 10T 3P 0 0	
N901	H01-WG03AB809UP-A	WIRE ASS'Y UL1007#26 STR 90MM 2.0MM 3P RED-UP	
	3SA-3150US-FCAR-1-5	AC ESABD ST-BY LED BD DPR1005	
D830	H01-DL3BA05V0BA-2	D-LEM BLUE/AMBER 3PIE RD RND CL L-3VYMBC	
N902	H01-WG03SB80500-2	WIRE ASS'Y 2.0MM 3P 50MM UL1007#26 RED	
	3SA-3150US-FCAR-1-5	AC ESABD CON1 BD DPR1005	
P811	H01-WN08AB100WH-7	CONNECT WAFER 2.0MM 8P 35237-0810 WHT	
P810	H01-WN08SB100WH-4	CONNECT WFER 2.0MM 8P 35336-0810 WHT	
	3SA-3150US-FCAR-1-5	AC ESABD CON2 BD DPR1005	
P813	H01-WN12AB00000-8	CONN WAFER 2.0MM 12P 35237-1210 WHT	

REF NO.	PARTS NO.	DESCRIPTION	TYPE
P812	H01-WN12SB100WH-7	CONN WAFER 2.0MM 12P 35336-1210 WHT	
3SA-3150US-FCAR-1-5 AC ESABD CON3 BD DPR1005			
C501 502 503 504	CCZID0104NA-2	CC 100NOF +80% -20% 50.0V F	
C505 506	CKKID0681NN-3	CC 680POF +10% -10% 50.0V 2B4	
P815	H01-WN11AB00000-0	CONN 2.0MM 11 MA R NAT SOCKET MOLEX 35237-1110 0 0	
P814	H01-WN11SB00000-8	CONN 2.0MM 11P MA ST NAT MOLEX 35336-1110 0 0	
B501 502	H01-FB3002012NN-4	FBEAD SURFACE MT 300OHM FCM2012V-301T07	
3SA-3150US-FCAR-1-5 AC ESABD CON4 BD DPR1005			
C510	CSDIE040ABG-1	CAP CHIP FORM,4P +/-0.25P,50V,0603,COG.	
P817	H01-WN11AB00000-0	CONN 2.0MM 11 MA R NAT SOCKET MOLEX 35237-1110 0 0	
P816	H01-WN11SB00000-8	CONN 2.0MM 11P MA ST NAT MOLEX 35336-1110 0 0	
3SA-3150US-FCAR-1-5 AC ESABD CON5 BD DPR1005			
P819	H01-WN06AB00001-4	CNT PLUG BD'BD SOCKET 2.0mm 35237-0610	
P818	H01-WN06SB01000-9	CNT PLUG BD'BD PLUG 2.0mm 35336-0610 6P	
3SA-3150US-OUMI-1-6 AC ESABD IMA OUT BD DPR1005			
	PBD04KOU120-4	PCB SINGLE DPR2005 OUT 174MMX144MM*1.6t FR-1	
C401 402 403	CCMPA0472NA-2	CAPACITOR CERAMIC 0.0047UF 400V M	
NJ41	H01-SOXA27014NN-9	CON MAINS INLET A/C INLET 7014-NGP AC05-4S020A	
P402	H01-WN02S12MM00-A	CONNECTOR WAFER B02P-VL 12.0MM 2P	
NJ42	H01-SOPA21275BK-3	CONN-SPE AC OUTLET 2P 110V FE 12.75MM 2 BK 0 0 A204D0043P	
F401	H01-FUGF23000XX-A	FUSE 239 SERIES 003 250V 3A	
SK41	H01-RL12112D1K-9	RELAY OSZ-SS-112DM8 16A 12V	
SK42	H01-RL1227111K-1	RELAYPWR 12.0V 270.0OHM 10.0A	
N402	H01-WG02SB84500-9	WIRE ASS'Y UL1007#26 STR 450MM 2.0MM 2P RED	
N403	H01-WG02SB82200-1	WIRE ASS'Y UL1007#26 STR 220MM 2.0MM 2P RED	
N401	H01-WG02SG84800-A	WIRE ASS'Y UL1617#22 STR 480MM 7.92/3.96MM 2P WHT	
3SA-3151US-OUAA-1-1 AC ESABD IAA OUT BD DPR1005			
D401 402	H01-DG1N04148NB-4	D-SLP 1N4148 100.0V 150E-3A	
R401 402	RC3DI0330IN-7	RESISTOR CARBON FILM 33 OHM 1/4W 5%	
FH41 42	H01-SOPS1FEHDNN-9	TERMFUSEHLDR FUSE-HOLDER J4210020001X	
3SA-3150US-OUMI-1-6 AC ESABD IMA REMOTE BD DPR1005			
BK51 52	H01-ZMC12S16A00-A	BKT GROUND	
C514	CCZID0104NA-2	CC 100NOF +80% -20% 50.0V F	
P501	H01-WN10SB00000-0	CONNECT 2.0MM 10P GIL-S-10P-S2T2-EF	
F501	H01-FURN2200006-6	FUSE T 2A 250V 7.6X8.6 SS-5 SAVE FUSETECH	
IC51 52 53	H01-ICPC17T10B1-2	IC PHOTOCOUPLER PC-17T1 DIP4 KODENSHI	
NJ51 52 53	H01-SOJW2350SNN-A	JACK PHONE 3.6 EP-1401A 1P BK	
NJ54	SO0A18P8CNN-7	JACK-TELE SNAP-IN GOLDEN TELECOM GDL1-8P8C 8T BK 0 0	
3SA-3151US-OUAA-1-1 AC ESABD IAA REMOTE BD DPR1005			
R515	RC3DI0101IN-0	RCF 100R0 OHM +5% 250MI0W	
3SA-3151US-OUAR-1-3 AC ESABD IAR REMOTE BD DPR1005			
C502	CEHFC01075E-1	CE 100UF +20% 16.0V D6.3XL11 P5MM 85C	
C501	H01-CEHIC0107AH-9	CE 100UF +20% 50.0V 85C SHL	
Q501 502 503	H03-TRKTA107MNA-2	TR-SLPSWA KRA107M P	
3SA-3151US-OUST-1-A AC ESABD SMD REMOTE BD DPR1005			
C503 504 505 506	CZJII0101BE-2	CCCFMIC 100P0F +5% -5% 50.0V NP0 0603	
C512 513	CZZFI0104BF-8	CAP CHIP 100NOF +80% -20% 16.0V Y5V 0603	
C511 D511 512	RS3AD0000NA-0	RMGCFMIC 0 OHM +0% 62MI5W	
D503 504 505 506	H01-DS1S50094NB-A	D-SLP 1SS355 35.0V 225MI0A	
L501 502	H01-FBK252012NN-5	FBEAD SURFACE MT 2500OHM FCM2012H-252T02	
R503	RS3AD0271NA-2	RMGCFMIC 270R0 OHM +5% 62MI5W	
R507 508	RS3AD0392NA-1	RMGCFMIC 3K9 OHM +5% 62MI5W	
R510 511	RS3AD0470NA-7	RMGCFMIC 47R0 OHM +5% 62MI5W	
R501 502 521 522	RS3AD0471NA-5	RMGCFMIC 470R0 OHM +5% 62MI5W	
R504 505 506	RS3AD0472NA-3	RMGCFMIC 4K7 OHM +5% 62MI5W	
R509	RS3AD0104NA-A	RMGCFMIC 100K0 OHM +5% 62MI5W	
3SA-3150US-POMI-1-6 AC EMBD IMA PROCESSOR BD DPR1005			
	PBD04KPOB20-A	PCB DUAL DPR2005 PRO 244MM*327MM*1.6t FR-4	
BK72	H01-ZMD03S09A00-1	BRACKET SHIELD POWER	
P13	H01-WN06SB01000-9	CNT PLUG BD'BD PLUG 2.0mm 35336-0610 6P	
P11 12	H01-WN11SB00000-8	CONN 2.0MM 11P MA ST NAT MOLEX 35336-1110 0 0	
P9	H01-WN13SB00000-2	CONN 2.0MM 13P GIL-S-13P-S2T2	
P7	H01-WN04SB00000-3	CONN 2.0MM 4 MA ST NAT GT201-4P-TS	
P10	H01-WN07SB00001-9	CONN 2.0MM 7P GIL-S-7P-S2T2-EF	
P3	H01-WN17S100000-5	CONN FFC 1.25MM 17P SCB-1117-00-2 VER	
P14	H01-WN13SI00000-6	CONN FFC 1.25MM SCB-1113-00-2 13P VER	
P5	H01-WN12SB100WH-7	CONN WAFER 2.0MM 12P 35336-1210 WHT	
P4	H01-WN10SD100WH-0	CONNECT WAFER 2.5MM 10 5267-10A 10P WHT	
P6	H01-WN08SB100WH-4	CONNECT WFER 2.0MM 8P 35336-0810 WHT	
Y1	H01-OSCN120MOCU-6	CSTLS20MOX51-B0	
IC21	H01-ICNJM4556B2-7	IC OP AMP NJM4556AD DIP8	
IC54	H01-ICKA78R08API	IC-KA78R08API TO-220IS-4PIN	
NJ1	H01-SORA40GNDNN-7	JACK RCA 4P JB040131PN WWRR	
NJ15 5	H01-SORA40RSCNN-A	JACK RCA 4P JB040131QN WH BU RD GY	
NJ16 6	H01-SORA40RSANN-6	JACK RCA 4P JB040131ZN GN BN PP TA	

REF NO.	PARTS NO.	DESCRIPTION	TYPE
NJ2 3 4	H01-SORA64105NN-5	JACK RCA 6P JB060132PN	
Y2	H01-OSCEM12M2RU-9	OSCILLATOR 12.288MHz 3.3V	
FG1 2 3 4 6 7 8	H01-ZMB01S02200-9	SPRING PLATE GND C5212 0.2T	
N2	H01-WS3262105FN-9	WIRE ASS'Y 2.0MM 3P 210MM UL2547#26 RED STR	
W100	H01-WC1220305C1-0	WIRE ASS'Y UL1007 #22 TC30MM 1P BLK	
N1	H01-WS0263805FN-6	WIRE ASS'Y UL2547/1007#26 380MM 2.0MM 10P RED	
	3SA-3151US-POAA-1-1	AC ESABD IAA PROCESSOR BD DPR1005	
L3 5 6	H01-LAINB047ACR-3	LF 4U7H +10% 1.7 OHM 190.0A	
R431 440 500 509	RC3DI0181IN-9	RCF 180 OHM +5% 250MI0W	
D15 16	H01-DR1N04004NA-1	D-SR 1N4004 400.0V 1.0A	
L1 13	H01-LA1340470NN-4	INDUCTOR COIL AL04TB470K 47UH 1.34OHM	
L7	H01-DG1N04148NB-4	D-SLP 1N4148 100.0V 150E-3A	
	3SA-3151US-POAR-1-3	AC ESABD IAR PROCESSOR BD DPR1005	
C10 102 103 111 119	CEHFC01062S-0	CE 10UF +20% 16V D4XL7 P2.5MM 2000hours 85C	
120 128 129 13 133			
134 139 14 140 147			
148 149 150 151 152			
159 160 161 162 173			
176 185 186 191 192			
193 194 197 198 199			
200 212 215 216 219			
226 229 244 245 339			
342 343 345 346 347			
348 349 350 351 352			
368 369 371 372 377			
378 384 385 386 387			
392 393 396 397 400			
409 417 445 446 449			
452 469 470 483 489			
490 491 500 505 520			
521 522 525 526 546			
547 556 557 560 561			
566 567 570 571 73 74			
77 78 79 80 83 84 85			
86 89 9 90 91 92 95			
96 579			
C122 131 136 138 177	CEHFC01072S-9	CE 100UF +20% 16V D6.3XL7 P2.5MM 2000hours 85C	
20 203 21 27 277 280			
281 293 294 3 323 324			
353 424 456 461 463			
464 468 473 475 482			
494 495 501 508			
C125 126 137 142 145	CEHFC04762S-0	CE 47UF +20% 16V D5XL7 P2.5MM 2000hours 85C	
155 157 163 165 167			
170 171 174 175 18 19			
195 196 222 225 248			
249 276 279 287 288			
299 300 305 306 311			
312 317 318 329 330			
335 336 358 359 364			
365 370 383 388 403			
404 426 447 459 492			
499 545 558 559 562			
563 568 569 75 76 81			
82 87 88 93 94			
C523	CEHIC01042S-5	CE 100NF +20% 50V SSE TYPE D4XL7 P2.5MM 85C	
C123 127 498	CEHIC01055E-6	CE 1UF +20% 50V D5XL11 P5MM 85C	
C113 114 534	H01-CEHIC0225AH-5	CE 2U2F +20% 50.0V 85C 5X11 SHL	
C830	CEMFC0226NN-9	CAP ELEC 22UF 16V M ELITE	
Q38	H01-TRMPSA06NNA-4	TR-SLPLF MPSA06 N 500MI0A TO-92	
C549	H01-CEMFC0107MN-3	CE 100UF 16V M 5X11 SHL P2.5MM	
C573 574	CEMHC0107NN-3	CE 100UF 35V M 6.3X11	
C550 551 552 553 575	H01-CEMFC0477AH-A	CE 470UF 16V M 8X11.5 SHL	
576 577			
C253 254	H01-CEMFC0337NN-5	CE 330UF 16V M 8X11.5 SHL	
	3SA-3150US-POSB-1-7	AC ESABD SMD BOT PROCESSOR BD DPR1005	

REF NO.	PARTS NO.	DESCRIPTION	TYPE
C1 100 164 166 168 169 178 2 201 202 206 207 211 213 214 217 218 220 221 223 230 231 232 233 236 237 241 242 250 251 255 259 29 30 31 32 33 34 35 36 37 38 389 39 399 40 405 41 410 419 42 43 438 439 440 44 45 46 47 472 477 48 485 49 50 509 51 512 511 513 514 52 527 53 539 54 55 56 57 58 59 60 61 62 63 64 65 66 67 68 69 70 71 72 97 98 99 587	CZJII0101BE-2	CCCFMIC 100P0F +5% -5% 50.0V NP0 0603	
C289 290 297 298 319 320 327 328 375 376 379 382	CZJII0181BE-0	CCCFMIC 180P0F +5% -5% 50.0V NP0 0603	
C274 275 307 308 309 310 337 338 356 357 366 367	CZJII0271BE-A	CAP CHIP, 270PF 50V +/-5% CH J 0603	
C106 107 108 109 11 110 118 12 15 16 183 184 189 190 22 23 240 243 269 270 420 423 548 564 565 572	CZJII0330BE-9	CCCFMIC 33P0F +5% -5% 50.0V NP0 0603	
C586 C411 414 416 C421 C373 374 380 381 390 398 422 432 465 466 486 487 506 507 529 532	CZKII0102BC-7 CZKII0103BC-5 CZKII0122BC-1 CZKII0182BC-5	CAP CHIP 1N0F +10% -10% 50.0V X7R 0603 CAP CHIP 10N0F +10% -10% 50.0V X7R 0603 CAP CHIP 1N2F +10% -10% 50.0V X7R 0603 CAP CHIP 1N8F 50V X7R K 0603	
C172 C143 144 156 158 C460 467 C141 146 153 154 394 395	CZKII0223BC-6 CZKII0272BC-4 CZKII0472BC-7 CZKII0561BC-8	CAP CHIP 22N0F +10% -10% 50.0V X7R 0603 CAP CHIP 2N7F +10% -10% 50.0V X7R 0603 CAP CHIP 4N7F 50V X7R K 0603 CAP CHIP 560P0F +10% -10% 50.0V X7R 0603	
C130 135 204 205 208 209 210 224 24 246 247 25 252 256 257 26 260 261 262 263 264 265 266 271 272 28 425 427 428 429 430 431 433 434 435 436 441 442 443 444 448 450 451 453 454 455 457 471 474 479 480 481 497 5 502 504 510 517 518 519 524 528 530 531 533 537 554 555 818 907 908 915 916	CZZFI0104BF-8	CAP CHIP 100N0F +80% -20% 16.0V Y5V 0603	
D1 2 4 5 14 25 D12 20 21 22 L12 17 2 22 28 30 4 IC45 IC6 IC9 Q16 18 25 42 58 59 Q31 32 33 36 53 Q12 13 26 39 7 8 R605 606 610 614 R632 638 641 642 653 656 659 660 692 693 696 699	H01-DS1S50094NB-A H01-DSUDZ05V1NB-4 H01-FB3002012NN-4 H01-ICKIC9459D5-8 H01-ICLM02068D2-A H01-ICTC9273NDA-0 H01-TRDTA114YNI-9 H01-TRDTC114YNI-5 H01-TRKTD1304ND-5 RS1AD0153NA-2 RS1AD0303NA-9	D-SLP 1SS355 35.0V 225MI0A DIODE ZENER UDZ5.1B 5.1V 200MI0W FBEAD SURFACE MT 300OHM FCM2012V-301T07 IC-LOWFREQ KIC9459F SOP24 TONE/VOL/BAL/MUTE IC-OPERAMP NJM2068M DUAL SOP8 IC-SWITCH TC9273F-004 SOP28 ANALOG SWITCH TR-SSD DTA114YKA P 10K0 OHM 47K0 OHM TR-SSD DTC114YKA N 10K0 OHM 47K0 OHM TR-SLPSWA KTD1304 N 20V 300MI0A SOT-23 RES CHIP 15K OHM 1/16W 1% 0603 RES CHIP 30K OHM 1/16W 1% 0603	
C401 R443 513 592 594 595 596	RS3AD0100NA-7 RS3AD0101NA-5	RMGCFMIC 10R0 OHM +5% 62MI5W RMGCFMIC 100R0 OHM +5% 62MI5W	

REF NO.	PARTS NO.	DESCRIPTION	TYPE
R100 103 104 105 106 108 118 119 129 130 159 161 162 163 164 166 168 172 174 242 243 248 249 250 251 252 258 259 26 267 268 27 270 280 290 300 376 377 423 424 425 426 484 485 512 633 634 643 644 654 655 664 665 689 691 697 698	RS3AD0102NA-3	RMGCFMIC 1K0 OHM +5% 62MI5W	
R107 111 112 236 276 277 287 288 289 291 301 302 303 304 314 315 316 321 337 341 342 343 354 355 356 357 373 374 375 464 466 473 474 527 528 580 589 8 9 624 651	RS3AD0103NA-1	RMGCFMIC 10K0 OHM +5% 62MI5W	
R32 33 34 35 42 43 46 465 469 47 56 57 58 59 64 65 84 85 90 91	RS3AD0104NA-A	RMGCFMIC 100K0 OHM +5% 62MI5W	
R12 13 136 137 147 148 328 329 339 340 370 378 432 433 451 460	RS3AD0122NA-8	RMGCFMIC 1K2 OHM +5% 62MI5W	
R16 17 320 323 358 359 382 383	RS3AD0151NA-1	RMGCFMIC 150R0 OHM +5% 62MI5W	
R603 604 611 613 R227 C408 R124 128 139 140 418 430 588	RS3AD0182NA-1 RS3AD0221NA-6 RS3AD0222NA-4	RES CHIP,1.8K,1/16W,+/-5%,0603. RMGCFMIC 220R0 OHM +5% 62MI5W RMGCFMIC 2K2 OHM +5% 62MI5W	
R476 R177 178 R623 650 R415 526 534 R176 179 R224 246 247 260 261 265 266 274 275 30 31 36 37 38 39 40 41 44 45 48 49 52 53 54 55 60 61 62 63 66 67 86 87	RS3AD0222ANA-7 RS3AD0242NA-9 RS3AD0302NA-6 RS3AD0332NA-8 RS3AD0392NA-1 RS3AD0471NA-5	RMGCFMIC 2R2 OHM +5% 62MI5W RMGCFMIC 2K4 OHM +5% 62MI5W RMGCFMIC 3K0 OHM +5% 62MI5W RMGCFMIC 3K3 OHM +5% 62MI5W RMGCFMIC 3K9 OHM +5% 62MI5W RMGCFMIC 470R0 OHM +5% 62MI5W	
R167 2 229 4 5 529 530 531 549 570 571 673 675	RS3AD0472NA-3	RMGCFMIC 4K7 OHM +5% 62MI5W	
R14 15 169 173 201 203 207 211 212 324 325 348 350 380 381 402 403 486 487 497 616	RS3AD0473NA-1	RMGCFMIC 47K0 OHM +5% 62MI5W	
R171 175 223 278 279 312 313 322 326 371 372 674 676	RS3AD0512NA-6	RMGCFMIC 5K1 OHM +5% 62MI5W	
R135 141 144 146 R206 R216 R24 25 R470 471	RS3AD0562NA-2 RS3AD0682NA-3 RS3AD0911NA-3 RS3AD0912NA-1 RS3AD0272NA-0	RMGCFMIC 5K6 OHM +5% 62MI5W RMGCFMIC 6K8 OHM +5% 62MI5W RMGCFMIC 910 OHM +5% 62MI5W RMGCFMIC 9K1 OHM +5% 62MI5W RMGCFMIC 2K7 OHM +5% 62MI5W	
C17 238 239 258 462 515 516 541 580 581 582 583	3SA-3151US-POST-1-A CZJII0101BE-2	AC ESABD SMD TOP PROCESSOR BD DPR1005 CCCFMIC 100P0F +5% -5% 50.0V NP0 0603	
C115 116 234 235 406 407 542 543 544	CZJII0330BE-9	CCCFMIC 33P0F +5% -5% 50.0V NP0 0603	
C535 C291 292 295 296 321 322 325 326 354 355 540	CZJII0680BE-4 CZKII0102BC-7	CAPACITOR CERAMIC CHIP 68PF 50V CH J NPO 0603 CAP CHIP 1N0F +10% -10% 50.0V X7R 0603	
C536 C538	CZKII0122BC-1 CZKGI0183BC-6	CAP CHIP 1N2F +10% -10% 50.0V X7R 0603 CAP CHIP 18NF 25V +/-10% 0603 X7R	

REF NO.	PARTS NO.	DESCRIPTION	TYPE
C101 104 105 112 117 121 124 132 179 180 181 182 187 188 227 228 267 268 273 278 282 283 284 285 286 301 302 303 304 313 314 315 316 331 332 333 334 340 341 344 360 361 362 363 391 4 418 458 478 484 488 493 496 503 578 588 589 590 591 592 593 594 595 596 597 7 8 901 902 903 904 905 906 909 910 911 912 913 914 918 919	CZZFI0104BF-8	CAP CHIP 100N0F +80% -20% 16.0V Y5V 0603	
D13 17 3 6 D18 19 23 24 L10 11 14 15 16 18 19 20 21 23 24 25 26 27 29 31 32 33 34 35 41 42 44 47 48 8 9	H01-DS1S50094NB-A H01-DSUDZ05V1NB-4 H01-FB3002012NN-4	D-SLP 1SS355 35.0V 225MI0A DIODE ZENER UDZ5.1B 5.1V 200MI0W FBEAD SURFACE MT 300OHM FCM2012V-301T07	
IC26 IC57 IC60 IC10 22 IC56 IC15 IC61 IC24 IC58 IC62 IC44 IC14 IC52 IC12 13 16 17 18 19 2 20 25 27 28 29 3 30 31 32 33 34 35 36 37 38 39 4 40 41 42 46 47 5 7 8	H01-IC49L8192I5-A H01-IC74LS05MD5-1 H01-IC74VHC244G5-6 H01-ICAK05384DA-6 H01-ICBU4094BD3-2 H01-ICKIC9162DA-5 H01-ICCS42528EC-0 H01-ICCS4391AD8-5 H01-ICCS49400ED-3 H01-ICD703033E1-5 H01-ICDDX8228E6-5 H01-ICKIC9459D5-8 H01-ICK4S1616M6-9 H01-ICLM02068D2-A	IC-FLASH MEMORY ROM AT49LV8192A 70ns IC OPEN COLLECTOR INVER DM74LS05M SOP24 IC-LOGIC 74VHC244A INVERTER CMOS IC A/D CONVERTOR AK5384 SOP28 IC CMOS BU4094BF SOP16 IC-SWITCH KIC9162AF SOP28 ANALOG SWITCH IC-CODEC CS42528CQ IC CONV CS4391A-KZ SOP20 IC-DSP CS494003-CQ LQFP144 IC-MICOM FLASH NEC UPD70F3033BGF 0228KK001 JAPAN QFP100 IC MICOM DDX8228 TQFP64 IC-LOWFREQ KIC9459F SOP24 TONE/VOL/BAL/MUTE IC-SDRAM K4S161622E-TC70 OR TC80 IC-OPERAMP NJM2068M DUAL SOP8	
IC55 IC43 48 C402 412 413 415 476 IC1 IC70 IC11 Q11 14 15 17 21 44 47 48 51 Q28 29 30 34 35 37 52 Q1 10 19 2 20 22 23 24 27 3 4 40 41 43 45 46 49 5 50 54 55 56 57 6 9	H01-ICM24C04WD2-1 H01-ICNC7SV17XX-4 CZKII0103BC-5 H01-ICNJM2391D33-A H01-ICMM1662HI3-2 H01-ICTC9273NDA-0 H01-TRDTA114YNI-9 H01-TRDTC114YNI-5 H01-TRKTD1304ND-5	IC-EEPROM M24C04WMN6T IC NC7SV17 CAP CHIP 10N0F +10% -10% 50.0V X7R 0603 IC-NJM2391DL1-33 LOW VOLTAGE IC MM1662H LOW DROP VOLTAGE REGULATOR SOP-8 IC-SWITCH TC9273F-004 SOP28 ANALOG SWITCH TR-SSD DTA114YKA P 10K0 OHM 47K0 OHM TR-SSD DTC114YKA N 10K0 OHM 47K0 OHM TR-SLPSWA KTD1304 N 20V 300MI0A SOT-23	
C584 585 R115 158 446 459 462 463 475 492 577 578 579 612 R10 11 116 117 121 122 132 152 153 154 156 157 184 185 188 189 192 193 200 202 21 210 218 22 225 226 23 230 233 237 238 281 282 285 286 305 306 308 311 327 331 332 333 334 335 336 338 361 362 366 367 368 369 394 395 397 398 404 405 406 407 413 414 428 429 438 453 454 455 456 457 458 461 478 479 482 502 523 550 551 559 560 561 562 563 564 565 566 569 587 590 615 622 627 629 631 647 652 663 666 679 680 7 700 72 73 78 79 88 89 94 95	RS3AD0000NA-0 RS3AD0100NA-7 RS3AD0101NA-5	RMGCFMIC 0 OHM +0% 62MI5W RMGCFMIC 10R0 OHM +5% 62MI5W RMGCFMIC 100R0 OHM +5% 62MI5W	

REF NO.	PARTS NO.	DESCRIPTION	TYPE
R1 120 123 145 150 253 254 255 439 442 445 447 448 505 506 507 508 520 521 522 546 547 548 568 575 582 6 617	RS3AD0102NA-3	RMGCFMIC 1K0 OHM +5% 62MI5W	
R412 467 493 496 503 504 514 515 518 532 535 538 540 541 542 543	RS3AD0103NA-1	RMGCFMIC 10K0 OHM +5% 62MI5W	
R125 126 155 160 18 180 181 186 187 19 190 191 196 197 198 199 208 209 213 214 215 222 239 240 318 319 360 363 384 385 392 393 396 401 408 409 410 417 436 437 449 450 519 583 584 585 586 618 619 620 625 626 628 636 637 648 649 661 662 671 672 68 69 713 714 74 75 76 77 82 83 92 93 98 99	RS3AD0104NA-A	RMGCFMIC 100K0 OHM +5% 62MI5W	
R411 420 422 552 R101 142 143 149 151 R498 R109 110 113 114 133 134 165 170 217 219 244 245 257 262 263 264 272 273 419 421 427 480 488 489 495 50 51 517 574 581 678	RS3AD0151NA-1 RS3AD0512NA-6 RS3AD010ANA-6 RS3AD0222NA-4	RMGCFMIC 150R0 OHM +5% 62MI5W RMGCFMIC 5K1 OHM +5% 62MI5W RES, CHIP, 1, 1/16W, +/-5%, 0603 RMGCFMIC 2K2 OHM +5% 62MI5W	
R231 444 490 491 621 682 R539 R292 293 294 295 296 297 298 299 344 345 346 347 349 351 352 353 555 556 557 558 R472 481 525 533 536 537 544 R182 183 194 195 204 205 28 29 390 391 399 400 434 435 599 601 630 635 667 668 70 71 80 81 96 97 R138 220 228 232 234 241 256 269 271 283 284 330 379 416 468 524 573 677 R221 3 307 309 310 317 364 365 388 389 516 R545 R127 131 R235 R602 609 RS1 3 4 5 RS10 11 12 13 14 6 7 8 9 R102 499 591 600 607 608 639 640 645 646 657 658 669 670 685 687 694 695 R386 387 510 511 IC23 59 R441 572 R553 554 593 597 598 567 576 C851 R452 494 RS2 R477 R483 C603 C601 C602 C437 R20	RS3AD022ANA-7 RS3AD0302NA-6 RS3AD0331NA-A RS3AD0332NA-8 RS3AD0471NA-5 RS3AD0472NA-3 RS3AD0473NA-1 RS1AD3321NA-3 RS3AD0561NA-4 RS3AD0562NA-2 RS3AD047ANA-6 RS3AY0103NA-7 RS3AY0470NA-2 RS3AD0432NA-4 RS3AD0910NA-5 H01-IC74V244MG5-3 RS3AD0202NA-A RS3AD0221NA-6 CZJII0471BE-2 RS3AD0121NA-A RS3AY0332NA-3 RS3AD0470NA-7 RS3AD0750NA-1 CSDIE040ABG-1 CCZID0104NA-2 CEHFC01062S-0 CEZXA0479MN-5 RC3DI0222IN-A	RMGCFMIC 2R2 OHM +5% 62MI5W RMGCFMIC 3K0 OHM +5% 62MI5W RMGCFMIC 330R0 OHM +5% 62MI5W RMGCFMIC 3K3 OHM +5% 62MI5W RMGCFMIC 470R0 OHM +5% 62MI5W RMGCFMIC 4K7 OHM +5% 62MI5W RMGCFMIC 47K0 OHM +5% 62MI5W RES CHIP 3.32K OHM 1/16W 1% 0603 RMGCFMIC 560R0 OHM +5% 62MI5W RMGCFMIC 5K6 OHM +5% 62MI5W RES CHIP, 4R7 1/16W +/-5%, 0603. RCA 10K0 OHM +5% 62MI5W 4 RCA 47R0 OHM +5% 62MI5W 4 RMGCFMIC 4K3 OHM +5% 62MI5W RES CHIP 910HM 1/16W 5% 0603 IC-LOGIC 74VHCT244A INVERTER CMOS RMGCFMIC 2K0 OHM +5% 62MI5W RMGCFMIC 220R0 OHM +5% 62MI5W CCCFMIC 470P0F +5% -5% 50.0V NP0 0603 RMGCFMIC 120R0 OHM +5% 62MI5W RCA 3K3 OHM +5% 62MI5W 4 RMGCFMIC 47R0 OHM +5% 62MI5W RMGCFMIC 75R0 OHM +5% 62MI5W CAP CHIP FORM, 4P +/-0.25P, 50V, 0603, COG. CC 100NOF +80% -20% 50.0V F CE 10UF +20% 16V D4XL7 P2.5MM 2000hours 85C CM 47MIOF +80% -20% 5.5V 70C RCF 2K2 OHM +5% 250MI0W	

REF NO.	PARTS NO.	DESCRIPTION	TYPE
	3SA-3150US-POMI-1-6	AC EMBD IMA PWR SW BD DPR1005	
P821	H01-WN02SE00000-6	CON 3.96MM PITCH HEADER 2 POS MOLEX 35328-0210	
P820	H01-WN02SB00000-9	CONN 2.0MM 2 MA ST NAT GT201-2P-TS	
SW80	H01-SWE4A21PDA%-5	SWITCH POWER SDKVB10100 5A 250V 4P	
	3SA-3151US-VDMI-1-9	AC EMBD IMA VIDEO BD DPR1005	
	PBD04KVDI20-5	DPR2005 VIDEO SINGLE PCB 194MM*219MM*1.6t FR-1	
P102	H01-WN13SB00000-2	CONN 2.0MM 13P GIL-S-13P-S2T2	
P101	H01-WN12AB00000-8	CONN WAFER 2.0MM 12P 35237-1210 WHT	
P100	H01-WN08AB100WH-7	CONNECT WAFER 2.0MM 8P 35237-0810 WHT	
Y100	H01-OSXBEL4M3AU-7	CRYSTAL 14.31818MHZ WOON	
Y101	H01-OSXBEL7M7AU-9	CRYSTAL 17.734475MHZ WOON	
IC32	H01-ICKIA7806I2-9	IC KIA7806AP VOLTQAGE REGULATOR TO-220AB	
NJ19	H01-SORA90173NN-6	JACK RCA 9P JB090173FN	
NJ10 11 12 13 14 15 16 17	H01-SORALL1Y00NN-5	JACK RCA+S VIDEO C5016031DN	
SK10 11	H01-RLL0517811A-A	RELAY D3009(1-1462033-4)	
	3SA-3151US-VDAA-1-7	AC ESABD IAA VIDEO BD AXIAL DPR1005	
D102 104	H01-DG1N04148NB-4	D-SLP 1N4148 100.0V 150E-3A	
L100 101 102	H01-FB05B3580NN-1	BEAD AXIAL/TAP,HC3580 80.5ohm	
L107	H01-LAINB056ACR-0	LF 5U60H +10% 5.8 OHM 500MI0A	
L104 105 106 108 110	H01-LAINB0470CR-2	LF 47U0H +10% 5.8 OHM 500MI0A	
	3SA-3151US-VDAR-1-9	AC ESABD IAR VIDEO BD DPR1005	
C104 106 107 109 115 117 122 124 125 127 155 156 163 165 220 244 248 252 263	CEHEC02275E-9	CE 220UF +20% 10.0V D6.3XL11 P5MM 85C	
C269	CEHIC01065E-4	CE 10U0F +20% 50.0V 85C P5MM 5X11	
C149 150 151 152 157 158 159 160 161 162 166 167	CEHEC0477MN-A	CE 470U0F +20% 10.0V 6.3XL11 85C ELITE	
C105 108 112 116 123 126 164 183 186 191 238 247 251 264	H01-CEHFC0106AH-5	CE 10U0F +20% 16.0V 85C AH SAMYOUNG	
C188 193 198 229 231 233 236 239 242 245 249 266 267 268	CEHFC01075E-1	CE 100UF +20% 16.0V D6.3XL11 P5MM 85C	
C102 215	CEMFC0226NN-9	CAP ELEC 22UF 16V M ELITE	
C154 172 174 179 222 235 241	CEHFC04765E-3	CE47UF +20% 16.0V D5XL11 P5MM 85C	
C195 204 208 213	CEHIC01055E-6	CE 1UF +20% 50V D5XL11 P5MM 85C	
C185 189	H01-CEHIC0225AH-5	CE 2U2F +20% 50.0V 85C 5X11 SHL	
C205	CEHIC0474NN-9	CE 470N0F +20% 50.0V 85C 5X11 ELITE	
C194	CPIIC0223NN-4	CPF 22N0F +10% 50.0V	
C196	CPIIC0682NN-5	CPF 6N8F +10% 50.0V	
Q101 104 114 116	H01-TR2SA933ANW-2	TR-SLPLF 2SA933ASR P -3.0A -20V	
Q100 117	H01-TR2SC1740NW-9	TR-SLPLF 2SC1740S R N 150MI0A 50V	
Q115	H01-TRMPSA56YNA-5	TR-SLPLF MPSA56 Y P -500MI0A -300V	
	3SA-3151US-VDST-1-5	AC ESABD SMD VIDEO BD DPR1005	
C200	CZEII0100BE-0	CCCFMIC 10P0F +0P5F -0P5F 50.0V NPO 0603	
C100 101 103 110 111 114 118 119 121 153 168 169 170 175 176 177 180 181 182 209 210 211	CZJII0101BE-2	CCCFMIC 100P0F +5% -5% 50.0V NPO 0603	
C202	CZJII0270BE-1	CCCFMIC 27P0F +5% -5% 50.0V NPO 0603	
C201	CZJII0330BE-9	CCCFMIC 33P0F +5% -5% 50.0V NPO 0603	
C203 206 207 214	CZJII0390BE-2	CAP CHIP 39PF 50V CH J NPO 0603	
C228	CZJII0181BE-0	CCCFMIC 180P0F +5% -5% 50.0V NPO 0603	
C184 187 192 197 199	CZKII0103BC-5	CAP CHIP 10N0F +10% -10% 50.0V X7R 0603	
C227	CZKII0561BC-8	CAP CHIP 56P0F +10% -10% 50.0V X7R 0603	
C171 173 178 221 225 226 232 234 237 240 243 246 250	CZZFI0104BF-8	CAP CHIP 100N0F +80% -20% 16.0V Y5V 0603	
C190	CZKII0223BC-6	CAP CHIP 22N0F +10% -10% 50.0V X7R 0603	
D100 101 103 106 107	H01-DS1S50094NB-A	D-SLP 1SS355 35.0V 225MI0A	
IC19 28	H01-ICBU4053BB4-7	IC BU4053BCF SOP16 ANALOG MPX/DEMPX	
IC29 30 31	H01-ICBU4094BD3-2	IC CMOS BU4094BF SOP16	
IC33	H01-ICLC74763I4-1	IC OSD LC74763M SOP30	
IC13 14 26	H01-ICMM1501XDL-A	IC-VIDEO SW MM1501XNRE SOT-26B	
IC16 17 18	H01-ICNJM2296D3-7	IC-LINEAR NJM2296	
IC27	H01-ICTSH95IDB4-6	IC-VIDEOPROC TSH95ID VIDEO AMPLIFIER	
Q102 103	H01-TRDTA114YNI-9	TR-SSD DTA114YKA P 10K0 OHM 47K0 OHM	
Q105 106 107 110 111 113	H01-TRDTC114YNI-5	TR-SSD DTC114YKA N 10K0 OHM 47K0 OHM	
R136 137 138 140 141 142 144 145 146 160 180 190 191 192 195 200 239	RS3AD0102NA-3	RMGCFMIC 1K0 OHM +5% 62MI5W	
R147	RS3AD0104NA-A	RMGCFMIC 100K0 OHM +5% 62MI5W	
IC15	H01-ICMM1511XDL-8	IC-VIDEO SW MM1511XNRE SOT-26B	
R182	RS3AD0101NA-5	RMGCFMIC 100R0 OHM +5% 62MI5W	

REF NO.	PARTS NO.	DESCRIPTION	TYPE
R100 104 105 112 117 118 122 126 127 158 159 163 165 179 199 201 210 211 212 213 214 215 238	RS3AD0103NA-1	RMGCFMIC 10K0 OHM +5% 62MI5W	
R185 188	RS3AD0105NA-8	RES CHIP 1M 1/16W +-5% 0603	
R186 187 197	RS3AD0121NA-A	RMGCFMIC 120R0 OHM +5% 62MI5W	
R162 166 167	RS3AD0122NA-8	RMGCFMIC 1K2 OHM +5% 62MI5W	
R139 143	RS3AD0123NA-6	RMGCFMIC 12K0 OHM +5% 62MI5W	
R202	RS3AD0124NA-4	RMGCFMIC 120K0 OHM +5% 62MI5W	
D108 109 110 111 112 113 114 115 116 117	H01-DS05GBUSCNB-A	DIODE PG05GBUSC	
R196	RS3AD0152NA-A	RMGCFMIC 1K5 OHM +5% 62MI5W	
R168 194	RS3AD0154NA-6	RMGCFMIC 150K0 OHM +5% 62MI5W	
R181	RS3AD0221NA-6	RMGCFMIC 220R0 OHM +5% 62MI5W	
R206 207	RS3AD0222NA-4	RMGCFMIC 2K2 OHM +5% 62MI5W	
R153 161 164 240	RS3AD0223NA-2	RMGCFMIC 22K0 OHM +5% 62MI5W	
R203	RS3AD0224NA-0	RMGCFMIC 220K0 OHM +5% 62MI5W	
R150 152	RS1AD1580NA-0	RES CHIP 1580HM 1% 1/16W 0603	
IC10 11 12	H01-ICMM1510XDL-7	IC-VIDEO SW MM1510XNRE SOT-26A	
R154	RS3AD0431NA-6	RES CHIP,430 OHM,1/16W,+/-5%,0603	
R241	RS3AD0180NA-5	RES CHIP 18 OHM 1/16W +/-5% 0603.	
R149	RS3AD0331NA-A	RMGCFMIC 330R0 OHM +5% 62MI5W	
R205 208	RS3AD0333NA-6	RMGCFMIC 33K0 OHM +5% 62MI5W	
R217 218 219 220 221 222 223 224 226 227 228 229 230 231 232 233 234 235 236	RS3AD010ANA-6	RES, CHIP, 1, 1/16W, +/-5%, 0603	
R155 156	RS3AD0430NA-8	RMGCFMIC 43R0 OHM +5% 62MI5W	
R176	RS1AD0471NA-A	RESISTOR CHIP 470OHM 1/16W 1% 0603	
R177	RS1AD0511NA-2	RES CHIP 510OHM 1% 1/16W 0603	
R193	RS3AD0513NA-4	RMGCFMIC 51K0 OHM +5% 62MI5W	
R204 209	RS3AD0680NA-7	RMGCFMIC 68R0 OHM +5% 62MI5W	
R198	RS3AD0682NA-3	RMGCFMIC 6K8 OHM +5% 62MI5W	
R101 102 103 106 107 108 109 110 111 119 120 121 128 129 130 131 132 133	RS1AD0750NA-6	RES CHIP 75OHM 1% 1/16W 0603	
R225	RS3AD0820NA-6	RMGCFMIC 82R0 OHM +5% 62MI5W	
R169	RS3AD0822NA-2	RMGCFMIC 8K2 OHM +5% 62MI5W	
R113 114 115 116 123 124 125	H01-RS1AD78R7NA-9	RES CHIP 78.7OHM 1% 1/16W 0603	
C230	CEHFC01075E-1	CE 100UF +20% 16.0V D6.3XL11 P5MM 85C	

COMPLETE SMPS POWER SUPPLY PCB ASS'Y - PART# H01-ZVD03S01300-8

COMPLETE TUNER MODULE(USA) - PART# H01-ZVD03TUNE00-9

DPR2005 MECHANICAL PARTS LIST

REF NO.	PARTS NO.	DESCRIPTION	TYPE
	3SA-3151US-BC00-1-9	AC MECH BOM DPR2005 HARMAN OEM	
	H01-ZVD03DWT434-7	TAPE AL PANEL DOOR	
	H01-ZMB01S00100-5	BKT HEADPHONE JACK	
	H01-ZMC12S19A00-2	BKT AC INLET	
	H01-ZMC12S20A00-2	BADGE AL HARMAN/KARDON SILVER	
	H01-ZMD03MAGN00-2	MAGNET	
	H01-ZMD03S00200-6	AL DOOR	
	H01-ZMD03S05A00-8	BRACKET MAGNET LEFT	
	ZSTBM3006BB-7	SCREW ST BH 3X6MM	
	H01-ZMD03S05AYE-6	STUD STANDOFF HEX M4X0.7 6X27.5H	
	H01-ZMD03S03AYE-4	STUD-1 H34MM	
	H01-ZMD03S04A00-7	BKT HINGE	
	H01-ZMD03S07A00-A	FRONT CHASSIS	
	H01-ZMD03S08A00-0	COVER TOP	
	ZKGEN97HA00-3	LABEL MAIN POWER REMIND	
	ZSTWM3A08BY-6	SCREW ST W7.5PH 3X8	
	H01-ZMD03S13A00-4	MAIN CHASSIS	
	ZFNR10803GY-1	DOOR RUBBER	
	H01-ZMD03S00300-8	AL PANEL DOOR	
	H01-ZMD04S11A00-0	PANEL REAR DPR2005	
	H01-ZPC1018GART-7	FILTER VFD	
	H01-ZMGEN00GAGY-0	AL LOGO BADGE TOP	
	H01-ZPD0301GASG-A	BUTTON DUMMY -1	
	H01-ZPD0302GASG-8	BUTTON DUMMY -2	
	H01-ZPD0303GASG-6	BUTTON DUMMY -3	
	H01-ZPD0304GASG-4	BUTTON DUMMY-4	
	H01-ZPD0305GASG-2	BUTTON DUMMY-5	
	H01-ZPD0306GAGY-3	BUTTON 1 KEY	
	H01-ZPD0307GAGY-1	BUTTON 4KEY	
	H01-ZPD0308GAGY-A	BUTTON 3KEY-B	
	H01-ZPD0309GAGY-8	BUTTON 5KEY	
	H01-ZPD0310GAGY-3	BUTTON 3 KEY-A	
	H01-ZPD0320GABK-8	DOOR HINGE-LEFT	
	H01-ZPD0313GAGY-8	MAGNET CASE	
	H01-ZPD0314GAMW-5	STANBY INDICATOR	
	H01-ZPD0315GAMW-3	VOLUMN KNOB	
	H01-ZPD0316GASG-A	COVER KNOB	
	H01-ZPD0317GACR-4	CAP KNOB VOLUMN	
	H01-ZPD0412GAGY-8	PANEL FRONT DPR2005	
	H01-ZPD0419GABT-3	WINDOW DISPLAY DPR2005	
	H01-ZVD03GEAR01-5	DAMPER GEAR DP102	
	H03-ZVD03TUNE00-4	TUNER MODULE KST-MV014MA	
	ZFNR19720SB-5	RUBBER FOOT 19.7X19.7X2T BK	
	ZKCL222HA00-2	LABEL RISK	
	ZKCL229HA00-7	LABEL DATE	
	ZKGEN29HA00-8	LABEL DATE BLANK	
	ZKCL281HA00-9	LABEL QC CHECK	
	ZKD0430HA00-3	LABEL SERIAL DPR2005	
	ZKGEN30HA00-6	LABEL SERIAL BLANK	
	ZKD0473HA00-4	LABEL BARCODE PKG DPR2005	
	ZKGEN73HA00-7	LABEL BARCODE BLANK	
	ZKD0495HA00-8	LABEL LICENSE DPR2005	
	ZPD0303GAGY-8	BUTTON POWER	
	H01-ZPD0318GAMW-8	INDICATOR VIDEO	
	ZPC1103GAGY-A	FOOT 50MM 15.8MM	
	ZSMWM4008BZ-2	SCREW M.S M4X8 W/H ZN PLATED	
	ZSTGM3010BB-3	SCREW ST BH 3X10 GROUND	
	ZSTBM3010BB-5	SCREW ST BH 3X10	
	ZSTWM3008BY-8	SCREW ST WPH 3X8	
	ZSTWM4008BC-3	SCREW ST WPH 4X8 SILVER CHROM	
	H01-ZPD0321GABK-6	DOOR HINGE-RIGHT	
	ZTB017030AA-4	CABLE TIE 100MM NYLON 6	
	ZUC1201AABK-7	SPONGE 30X30X10T BK	
	ZSTPM2006BZ-9	SCREW S-TPG,WASHER 4.8MM,2.0X6,ZI-PLATED	
	H01-ZMD04S12A00-1	SHIELD TUNER DPR2005	
	H01-FBD0480BR00-2	FCORE CLAMP FILTER LF80BR W5 SRH 16X28X9	
	H01-ZMB01S02200-9	SPRING PLATE GND C5212 0.2T	
	H01-ZMD03S05B00-A	BRACKET MAGNET RIGHT	
	H01-ZVD04001300-8	ASS'Y SMPS KJP-10013 120W	
	ZFNRB228700-8	POWER RUBBER	
	H01-WF13S1405FU-0	WIRE FFC CABLE DHCDF-13/140-P1.25-BT	
	H01-WF17S4505FU-5	WIRE FFC CABLE DHCDF-17/450-P1.25BT	
	H01-WG03SH83300-6	WIRE ASS'Y 6.2MM 3P 330MM UL1015#14 BLK	
	ZSTFM0306BN-2	SCREW S.T 3X6 F/H NI PLATED	
	H01-ZMD03S02A00-5	BRACKET MIDDLE	
	H01-ZMD03S03A00-6	BRACKET JACK	
	ZUC1203AABK-A	SPONGE 15X30X8T BK	
	XY1N250M0CL-5	GLUE, TRANSPARENT,CANDY STRIP,W=12MM,L=50M @M	
	H01-ZMD03S04AYE-5	STUD-3 H 11MM	
	ZUD040916BK-A	SPONGE VOLUMN	
	H01-WG10SD83820-9	WIRE ASS'Y 2.5MM 10P 380MM UL1007#20 STR RED	
	XY1N033MODW-3	DOUBLE SIDE TAPE #Y-4615 (3M)	

DPR2005 MECHANICAL PARTS LIST

DPR2005 ELECTRICAL PARTS LIST

REF NO.	PARTS NO.	DESCRIPTION	TYPE
	ZWF793008PO-5	WASHER FIBER 3 0.8T	
	H01-ZMD03S10A00-1	SHIELD AMP DPR2005	
	H01-ZUD0301AABK-A	SPONGE-UL 30X30X12T BK DPR2005	
	ZQB0101AA00-4	SHIELD FOAM GASKET (WOORI)	
	ZSMWM3008BZ-7	SCREW M.S M3X8 W/H ZN PLATED	
	ZSTWM3006BY-1	SCREW S.T 3X6 W/H YELLOW ZINC PLATED	
	ZSTFM0308BN-9	SCREW S.T 3X8 F/H NI PLATED	
	H01-ZMD03S21A00-0	BKT SHIELD AMP DPR2005	
	H01-FBB0102AA00-7	FCORE FERRIT MAGNET SRH9. 9X20. 0X5. 1+CASE W5	
	XY1N218M3SW-4	GLUE FURROW W=12MML=18.3M SS WHITE @ROLL	
	XYDET00K500-6	DETERSIVE,N.W=0.5KG @BOTTL	
	XYVAS00K500-6	VASOGEN,YELLOW,N.W=0.5KG @BOTTL	
	XYALC01G000-2	ALCOHOL V=1.0GALLON @GALLON	
	XYGLAA5K200-3	GLASS CLEANER,N.W=0.52KG @BOTTL	
	XYKIFA4L500-1	KIF VEG LIQUID CAR WAX,V=0.445 L @BOTTLE	
	XY501110CRD-2	GLUE, RED #AK-501 F/SCREW V=110CC @BOTTL	
	XY1N250M0DW-4	GLUE,TAPE,#9070,W=12MM,L=50,DOUBLE-SIDE,WHITE. @METER	
	XY1P202K000-1	WIRE, TIN, D=1.2MM N.W=2.0KG @KG	
	XY57501K0YW-0	GLUE, YELLOW, N.W=1.0KG #575 @KG	
	XY1M3000000-6	MEMBRANE POLY TRANS W=1.3M @ROLL	
	XYEM501K000-2	SPECIALTY LUBRICANTS GREASE,#EM-50L,W=1KG @G	
	ZWM803305PZ-1	WASHER PLAIN 3	
	XY2N450M0DW-6	GLUE,TAPE,#9070,W=24MM,L=50,DOUBLE-SIDE,WHITE. @METER	
	3SA-3151US-FCMI-1-2	AC EMBD IMA FRONT BD DPR2005	
3SA-3151US-PA00-1-8		AC PKG BOM DPR2005	
	BTA3A1511SF-0	BATTERY ALKALINE 1.5V AAA	
	H03-ATLLF0146BY-5	ANTENNA LOOP SO146BY-100	
	H01-RYC1202HA00-5	REMOCON ZONE 2	
	H01-RYD0401HA00-2	REMOCON DPR2005	
	H03-WAB01200203-4	ANTENNA WIRE 75 CT02-FM 0 0	
	ZBP00122051-8	BAG PE 330 X245 T0.05	
	ZHC1201AAWH-A	FILM SHEET PE 920 X 1000	
	ZKC1113HA00-9	CARD WARRANTY	
	XY1N218M3CL-9	GLUE TRANSPARENT W=12MM L=18.3M @ROLL	
	ZKC11H96A00-1	POLISHING CLOTH	
	ZKC1214HA00-A	LABEL SAFETY LEAFLET	
	ZKC1270HA00-7	LABEL "PLEASE"	
	ZKD0401HA00-3	USER MANUAL DPR2005	
	ZKD0404HA00-2	BOX CARTON DPR2005	
	ZKD0452HA00-7	QUICK SET UP GUIDE DPR2005	
	ZKD0473HA00-4	LABEL BARCODE PKG DPR2005	
	ZKGEN73HA00-7	LABEL BARCODE BLANK	
	ZKGEN56HA00-5	ENVELOPE POLISHING CLOTH	
	ZQD0301HA00-A	CUSHION POLY (EPS)	
	H01-WAUSA2103BK-1	POWER CORD WS-004C+002E SJT#14*2C L=2M	
	ZBP00020350-4	POLYBAG BATTERY	
	XY7N636M5CL-8	Glue, Transparent,W=76mm, L=36.5m @m	
	XYJBLA4L800-5	WAX JUBILEE, CLEANER V=0.48LITER @BOTTLE	
	XYGLAA5K200-3	GLASS CLEANER,N.W=0.52KG @BOTTL	
	XY0M51K5M00-3	MEMBRANE POLY TRANS W=0.5M L=1.5KM @ROLL	
3SA-3151US-AMMI-1-6		AC EMBD IMA AMP BD DPR2005	
	PBD04KAMB20-A	PCB DUAL DPR2005 AMP 233.9MM*219MM *1.6t FR-4	
AMP1	H01-ZVD04012000-1	ASS'Y AMP MODULE GR0120-7	
C16 18 19 21	H01-CEMJA0228AH-3	CAP ELEC 2200UF 63V M SHL SAMYOUNG	
C37	H01-CEHJA0477MN-5	CE 470UOF M 63.0V 12.5X20 SHL	
P4	H01-WN06AB00001-4	CNT PLUG BD'BD SOCKET 2.0mm 35237-0610	
L1	H01-LCNN18190NA-4	COIL CHOKE 190UH TOROIDAL	
P6 7	H01-WN11AB00000-0	CONN 2.0MM 11 MA R NAT SOCKET MOLEX 35237-1110 0 0	
P3	H01-WN02SB00000-9	CONN 2.0MM 2 MA ST NAT GT201-2P-TS	
P5	H01-WN03SB00000-6	CONN 2.0MM 3 MA ST NAT GT201-3P-TS	
NJ3	H01-SOPA619BKNN-7	CONN-SPE TERMINAL SPKR 6P SH0611708P FE 19MM 6 BK 0 0	
NJ2	H01-SOPA81900NN-8	CONN-SPE TERMINAL SPKR 8P SH081136JP FE 19MM 8 -- 0 0	
D6	H01-DSBAT0054NB-7	DIODE BAT54 SMALL SIGNAL SOT-23	
D2	H01-DRSB36060NA-1	DIODE SCHOTTKY SB360 60V 3A DO-201AD	
HS1	H01-ZMD04HS0400-4	HEATSINK AMP	
IC2	H01-ICLMO259307-1	IC POWER CONVERTER LM2593HVT-ADJ TA07B	
IC1	H03-ICKIA7808I2-8	IC VOLTAGE REGULATOR KIA7808AP TO-220AB	
SH1	H01-ZMD03S20A00-A	SHIELD VIDEO	
N2	H01-WG08SE84600-1	WIRE ASS'Y UL1007#16 STR 460mm 3.96mm 8P RED	
N1	H01-WG02SD85300-4	WIRE ASS'Y UL1007#24 STR 530mm 2.5mm 2P GRY	
3SA-3151US-AMAA-1-4		AC ESABD IAA AMP BD DPR2005	
D1 3 4 5 7	H01-DR1N04004NA-1	D-SR 1N4004 400.0V 1.0A	
D8	H01-DR1N05819NA-6	DIODE SCHOTTKY RECTION 1N5819 40V 1A DO-41	
3SA-3151US-AMAR-1-6		AC ESABD IAR AMP BD DPR2005	
C42	CEHFC01075E-1	CE 100UF +20% 16.0V D6.3XL11 P5MM 85C	
C30 39	CEMFC0227NN-7	CAP ELEC 220UF 16V M5X11 ELITE	
C40	H01-CEMGA0108AH-1	CE KMG 1000UIOF M 25V 10X20 105C +-20%	
3SA-3151US-AMST-1-2		AC ESABD SMD AMP BD DPR2005	

REF NO.	PARTS NO.	DESCRIPTION	TYPE
C22 23 24 25 28 29 32 33 34 35 36 43 48 49 50	CZZFI0104BF-8	CAP CHIP 100N0F +80% -20% 16.0V Y5V 0603	
C15 17 20 31	CZIKI0104DC-3	CAP CHIP 100NF 100V X7R 10% 1206	
C38	CZKII0332BC-1	CAP CHIP 3N3F +10% -10% 50.0V X7R 0603	
C1 10 11 12 13 14 2 3 4 5 6 7 8 9	CZIKI0471DC-9	CAP CHIP 470PF 100V X7R 10% 1206	
B10 11 12 13 17	H01-FB2K52012NN-5	FBEAD SURFACE MT 2500OHM FCM2012H-252T02	
L2 6	H01-FB3002012NN-4	FBEAD SURFACE MT 300OHM FCM2012V-301T07	
R11 12 13 14	RS3CB0102NN-8	RES,CHIP,1K,1/8W,+/-5%,0805	
R20	RS3AD0103NA-1	RMGCFMIC 10K0 OHM +5% 62MI5W	
R4 5 8	RS3AD0102NA-3	RMGCFMIC 1K0 OHM +5% 62MI5W	
R1 2 19	RS3AD0432NA-4	RMGCFMIC 4K3 OHM +5% 62MI5W	
R7	RS3AD0472NA-3	RMGCFMIC 4K7 OHM +5% 62MI5W	
R10	RS3AD0511NA-8	RMGCFMIC 510R0 OHM +5% 62MI5W	
R9	RS3AD0822NA-2	RMGCFMIC 8K2 OHM +5% 62MI5W	
3SA-3151US-AMMI-1-6 AC EMBD IMA DIGITAL-IN BD DPR2005			
N5	H01-WN05SB00000-0	CONN 2.0MM 5 MA ST NAT GT201-5P-TS	
NJ10 11	H01-SOTOR179LBA-0	D-LEM TORX-179L	
NJ12	H01-SOTOT179LBA-7	D-LEM TOTX-179L	
NJ55	SOPA96063NN-0	JACK D-SUB 9P 87204-6063 W/DUST COVER BK	
NJ8	H01-SORA1J440CE-0	JACK RCA 1P PPJ-440CE	
NJ9	H01-SORA20130JN-9	JACK RCA 2P JB020130JN	
SK2	H01-RLL0516632B-A	RELAYPWR 5.0V 166.0OHM 1.0A 24.0V	
L11 12	H01-LF11030A2NA-4	TFPULSE TRANSFORMER 110UH FP-110 FERRIT MAGNET	
N3	H01-WSC261705EN-8	WIRE ASS'Y 13P 170MM UL1533/1007 #26 2.0MM RED SHIELD	
N4	H01-WS7261843EN-A	WIRE ASS'Y 7P 180MM UL1007/1533#26 BLK	
3SA-3151US-AMAA-1-4 AC ESABD IAA DIGITAL-IN BD DPR2005			
L3 4 5	H01-LAINB0470CR-2	LF 47UOH +10% 5.8 OHM 500MI0A	
3SA-3151US-AMAR-1-6 AC ESABD IAR DIGITAL-IN BD DPR2005			
C397 403 27 41	CEHFC01075E-1	CE 100UF +20% 16.0V D6.3XL11 P5MM 85C	
C392 393 394 395 401	CEHIC01055E-6	CE 1UF +20% 50V D5XL11 P5MM 85C	
3SA-3151US-AMST-1-2 AC ESABD SMD DIGITAL-IN BD DPR2005			
C396 404 413 416 423 424 437	CZZFI0104BF-8	CAP CHIP 100N0F +80% -20% 16.0V Y5V 0603	
C46	CZEII0100BE-0	CCCFMIC 10P0F +0P5F -0P5F 50.0V NP0 0603	
D9	H01-DS1S50094NB-A	D-SLP 1SS355 35.0V 225MI0A	
IC47 49	H01-ICM74H04MD4-2	IC-LOGIC M74HCU04M1R INVERTER HCT	
IC43	H01-ICUPD4721D8-3	IC-SPECFUNC UPD4721 DRIVERS/RECEIVERS CMOS RS-232C	
R484 15 493	RS3AD0153NA-8	RES CHIP,15K 1/16W,+/-5%,0603.	
R422 425 437	RS3AD0101NA-5	RMGCFMIC 100R0 OHM +5% 62MI5W	
R16 17 420 438	RS3AD0100NA-7	RMGCFMIC 10R0 OHM +5% 62MI5W	
R483 487 6	RS3AD0122NA-8	RMGCFMIC 1K2 OHM +5% 62MI5W	
R445	RS3AD022ANA-7	RMGCFMIC 2R2 OHM +5% 62MI5W	
R392 393	RS3AD0472NA-3	RMGCFMIC 4K7 OHM +5% 62MI5W	
R423 426 429 442 435	RS3AD0561NA-4	RMGCFMIC 560R0 OHM +5% 62MI5W	
R424 436	RS3AD0621NA-1	RMGCFMIC 620R0 OHM +5% 62MI5W	
R428 432 439	RS3AD0750NA-1	RMGCFMIC 750R0 OHM +5% 62MI5W	
Q3 4 5 26	H01-TRDTC114YNI-5	TR-SSD DTC114YKA N 10K0 OHM 47K0 OHM	
3SA-3151US-AMMI-1-6 AC EMBD IMA F-DIGITAL BD DPR2005			
P701	H01-WN03SB00000-6	CONN 2.0MM 3 MA ST NAT GT201-3P-TS	
NJ70	H01-SOTOR179LBA-0	D-LEM TORX-179L	
NJ71	H01-SORA1JE01NN-0	JACK RCA 1P JE010003MN GND OR	
NJ72	H01-SORAC5016NN-5	JACK S-VIDEO C50160272N	
BK71	H01-ZMD03S18A00-9	SHIELD DIGITAL	
FG96	H01-ZMB01S02200-9	SPRING PLATE GND C5212 0.2T	
N700	H01-WS5269805EN-A	WIRE ASS'Y UL1007/1533 #26 980MM 2.0MM 5P RED SHI	
3SA-3151US-AMAA-1-4 AC ESABD IAA DIGITAL-IN BD DPR2005			
L700	H01-LAINB0470CR-2	LF 47UOH +10% 5.8 OHM 500MI0A	
3SA-3151US-AMAR-1-6 AC ESABD IAR DIGITAL-IN BD DPR2005			
C704	CEHFC01072S-9	CE 100UF +20% 16V D6.3XL7 P2.5MM 2000hours 85C	
3SA-3151US-AMST-1-2 AC ESABD SMD DIGITAL-IN BD DPR2005			
C700	CZZFI0104BF-8	CAP CHIP 100N0F +80% -20% 16.0V Y5V 0603	
C47	CZZFI0104BF-8	CAP CHIP 100N0F +80% -20% 16.0V Y5V 0603	
C702 703	H03-DS05GBUSCNB-5	DIODE PG05GBUSC	
IC3	H01-ICM74H04MD4-2	IC-LOGIC M74HCU04M1R INVERTER HCT	
R21	RS3AD0221NA-6	RMGCFMIC 220R0 OHM +5% 62MI5W	
3SA-3151US-FCMI-1-2 AC EMBD IMA FRONT BD DPR2005			
P900	PBD07KFCI20-A	PCB SINGLE FRONT DPR2005 397MM*163MM*1.6t FR-4	
D902 903 904 905	H01-WN17AI00000-8	CONNECTOR FFC 17P 1.25MM ANG SCB-1017-00-2	
DP90	H01-VDHCA18LL03-7	D-LEM 30B3-20-15 GaN SUPER BLUE WATER CLEAR 15	
H901	ZPC1017GABK-6	FL HCA-18LL03	
RM90	H01-ICRPM6938NN-3	HOLDER VFD AVR430/630	
FG90 91 94 97	H01-ZMB01S02200-9	IC-REMOTE RPM6938-RSIP-A3 RECEIVER 38KHZ	
N900	H01-WG11SD84220-6	SPRING PLATE GND C5212 0.2T	
N602	H01-WG03SB80700-6	WIRE ASS'Y 11P 420MM UL1007#20 2.5MM STR	
		WIRE ASS'Y 2.0MM 3P 70MM UL1007#26 RED	
3SA-3151US-FCAA-1-0 AC ESABD IAA FRONT BD DPR2005			

REF NO.	PARTS NO.	DESCRIPTION	TYPE
R906 907	RC3DI0471IN-0	RCF 470R0 OHM +5% 250MI0W	
L901	H01-LAINB0470CR-2	LF 47U0H +10% 5.8 OHM 500MI0A	
R941 942	RC3DI010AIN-1	RCF 1R0 OHM +5% 250MI0W	
L900	H01-LAINB047ACR-3	LF 4U7H +10% 1.7 OHM 190.0A	
C907	CCZID0104NA-2	CC 100NOF +80% -20% 50.0V F	
L911 912	H03-FB05B3580NN-7	BEAD AXIAL/TAP,HC3580 80.5ohm	
	3SA-3151US-FCAR-1-2	AC ESABD IAR FRONT BD DPR2005	
C911	CEHFC04765E-3	CE47UF +20% 16.0V D5XL11 P5MM 85C	
C900 901	CPIKC0473NN-0	CPF 47NOF +10% 100.0V	
S900 901 902 903 904	H01-SWP1280APS1-8	SWITCH TACH JTP1280AP	
905 906 907 908 909			
910 911 912 913 914			
915 916 917 918 919			
Q901	H03-TRMPESA56YNA-0	TR-SLPLF MPSA56 Y P -500MI0A -300V	
	3SA-3151US-FCST-1-9	AC ESABD SMD FRONT BD DPR2005	
C606 902 910 912	CZZFI0104BF-8	CAP CHIP 100NOF +80% -20% 16.0V Y5V 0603	
913			
C908 909	CZZII0223BF-1	CAP CHIP 22NOF +80% -20% 50.0V Y5V 0603	
D603 604 919	H01-DSIS50094NB-A	D-SLP 1SS355 35.0V 225MI0A	
D918	H01-DSUDZ09V1NB-7	D-ZENER UDZS 9.1B 9.1V 200MI0W	
Q900 902 905	H01-TRDTC114YNI-5	TR-SSD DTC114YKA N 10K0 OHM 47K0 OHM	
R929 501	RS3AD0100NA-7	RMGCFMIC 10R0 OHM +5% 62MI5W	
R939 940	RS3AD0101NA-5	RMGCFMIC 100R0 OHM +5% 62MI5W	
R912 921 937	RS3AD0102NA-3	RMGCFMIC 1K0 OHM +5% 62MI5W	
R913 922	RS3AD0122NA-8	RMGCFMIC 1K2 OHM +5% 62MI5W	
R914 930	RS3AD0152NA-A	RMGCFMIC 1K5 OHM +5% 62MI5W	
R943	RS3AD0103NA-1	RMGCFMIC 10K0 OHM +5% 62MI5W	
R920 936	RS3AD0183NA-A	RMGCFMIC 18K0 OHM +5% 62MI5W	
R901 923 924	RS3AD0221NA-6	RMGCFMIC 220R0 OHM +5% 62MI5W	
R915 931	RS3AD0222NA-4	RMGCFMIC 2K2 OHM +5% 62MI5W	
R916 932	RS3AD0272NA-0	RMGCFMIC 2K7 OHM +5% 62MI5W	
R917 933	RS3AD0332NA-8	RMGCFMIC 3K3 OHM +5% 62MI5W	
R925 926	RS3AD0471NA-5	RMGCFMIC 470R0 OHM +5% 62MI5W	
R918 934	RS3AD0562NA-2	RMGCFMIC 5K6 OHM +5% 62MI5W	
Q904	H03-TRKTD1304ND-0	TR-SLPSWA KTD1304 N 20V 300MI0A SOT-23	
R910 911	RS3AD0683NA-1	RMGCFMIC 68K0 OHM +5% 62MI5W	
R919 935	RS3AD0822NA-2	RMGCFMIC 8K2 OHM +5% 62MI5W	
R902 903 904 905	RS3AD0000NA-0	RMGCFMIC 0 OHM +0% 62MI5W	
	3SA-3151US-FCAA-1-0	AC ESABD VID4 BD DPR2005	
C603 604 609 610	CZJII0101BE-2	CCCFMIC 100P0F +5% -5% 50.0V NP0 0603	
C605	CZJII0330BE-9	CCCFMIC 33P0F +5% -5% 50.0V NP0 0603	
D600 605	H01-DLRED3FRDBA-5	D-LEM RED/GREEN 3F RD RND CL	
NJ60	H01-SORA3W019NN-9	JACK RCA 3P JC03W0191N	
C602 D601 602	RS3AD0000NA-0	RMGCFMIC 0 OHM +0% 62MI5W	
R610	RS3AD0122NA-8	RMGCFMIC 1K2 OHM +5% 62MI5W	
R602 603 606 607	RS3AD0391NA-3	RMGCFMIC 390R0 OHM +5% 62MI5W	
R600 601 604 605 608	RS3AD0471NA-5	RMGCFMIC 470R0 OHM +5% 62MI5W	
0609			
FG93	H01-ZMD03S19A00-A	SPRING-A PLATE	
Q600 601 602 603	H01-TRDTC114YNI-5	TR-SSD DTC114YKA N 10K0 OHM 47K0 OHM	
W601	H01-WC1220405C1-9	WIRE ASS'Y UL1007 #22 TC 40MM 1P BLK	
N601	H01-WSC264805EN-3	WIRE ASS'Y UL1007/1533 #26 480MM 2.0MM 13P RED SHIELD	
	3SA-3151US-FCAA-1-0	AC ESABD H/P BD DPR2005	
C800	CZZFI0104BF-8	CAP CHIP 100NOF +80% -20% 16.0V Y5V 0603	
C801 802	CZKII0222BC-8	CAP CHIP 2N2F +10% -10% 50.0V X7R 0603	
C803	CCZID0104NA-2	CC 100NOF +80% -20% 50.0V F	
D800 801	H01-DSIS50094NB-A	D-SLP 1SS355 35.0V 225MI0A	
NJ80	H01-SOSS9CKX3NN-9	JACK PHONE 6.35 H70980110S 9P BK	
L800	H01-LAINB0470CR-2	LF 47U0H +10% 5.8 OHM 500MI0A	
R800 801	RS3AD022ANA-7	RMGCFMIC 2R2 OHM +5% 62MI5W	
FG81	H01-ZMB01S02200-9	SPRING PLATE GND C5212 0.2T	
N800	H01-WS4265805FN-A	WIRE ASS'Y UL1007/2547 #26 580MM 2.0MM 4P RED	
	3SA-3151US-FCAA-1-0	AC ESABD ENCODER BD DPR2005	
C600 601	CZKII0821BC-8	CAP CHIP 820P0F +10% -10% 50.0V X7R 0603	
VR60	H01-SWE3A0505S1-9	SWIROT ECL16B24204 5V 500U0A 10T 3P 0 0	
N901	H01-WG03AB809UP-A	WIRE ASS'Y UL1007#26 STR 90MM 2.0MM 3P RED-UP	
	3SA-3151US-FCAA-1-0	AC ESABD ST-BY LED BD DPR2005	
D830	H01-DL3BA05V0BA-2	D-LEM BLUE/AMBER 3PIE RD RND CL L-3VYMBC	
N902	H01-WG03SB80500-2	WIRE ASS'Y 2.0MM 3P 50MM UL1007#26 RED	
	3SA-3151US-FCAA-1-0	AC ESABD CON1 BD DPR2005	
P811	H01-WN08AB100WH-7	CONNECT WAFER 2.0MM 8P 35237-0810 WHT	
P810	H01-WN08SB100WH-4	CONNECT WFER 2.0MM 8P 35336-0810 WHT	
	3SA-3151US-FCAA-1-0	AC ESABD CON2 BD DPR2005	
P813	H01-WN12AB00000-8	CONN WAFER 2.0MM 12P 35237-1210 WHT	
P812	H01-WN12SB100WH-7	CONN WAFER 2.0MM 12P 35336-1210 WHT	

REF NO.	PARTS NO.	DESCRIPTION	TYPE
3SA-3151US-FCAA-1-0 AC ESABD CON3 BD DPR2005			
C501 502 503 504	CCZID0104NA-2	CC 100NOF +80% -20% 50.0V F	
C505 506	CKKID0681NN-3	CC 680POF +10% -10% 50.0V 2B4	
P815	H01-WN11AB00000-0	CONN 2.0MM 11 MA R NAT SOCKET MOLEX 35237-1110 0 0	
P814	H01-WN11SB00000-8	CONN 2.0MM 11P MA ST NAT MOLEX 35336-1110 0 0	
B501 502	H01-FB3002012NN-4	FBEAD SURFACE MT 300OHM FCM2012V-301T07	
3SA-3151US-FCAA-1-0 AC ESABD CON4 BD DPR2005			
C510	CSDIE040ABG-1	CAP CHIP FORM,4P +-0.25P,50V,0603,C0G.	
P817	H01-WN11AB00000-0	CONN 2.0MM 11 MA R NAT SOCKET MOLEX 35237-1110 0 0	
P816	H01-WN11SB00000-8	CONN 2.0MM 11P MA ST NAT MOLEX 35336-1110 0 0	
3SA-3151US-FCAA-1-0 AC ESABD CON5 BD DPR2005			
P819	H01-WN06AB00001-4	CNT PLUG BD'BD SOCKET 2.0mm 35237-0610	
P818	H01-WN06SB01000-9	CNT PLUG BD'BD PLUG 2.0mm 35336-0610 6P	
3SA-3151US-OUMI-1-3 AC ESABD IMA OUT BD DPR2005			
C401 402 403	PBD04KOU120-4	PCB SINGLE DPR2005 OUT 174MMX144MM*1.6t FR-1	
NJ41	CCMPA0472NA-2	CAPACITOR CERAMIC 0.0047UF 400V M	
P402	H01-SOXA27014NN-9	CON MAINS INLET A/C INLET 7014-NGP AC05-4S020A	
NJ42	H01-WN02S12MM00-A	CONNECTOR WAFER B02P-VL 12.0MM 2P	
F401	H01-SOPA21275BK-3	CONN-SPE AC OUTLET 2P 110V FE 12.75MM 2 BK 0 0 A204D0043P	
SK41	H01-FUGF23000XX-A	FUSE 239 SERIES 003 250V 3A	
SK42	H01-RLL12112D1K-9	RELAY OSZ-SS-112DM8 16A 12V	
N402	H01-RLL1227111K-1	RELAYPWR 12.0V 270.0OHM 10.0A	
N403	H01-WG02SB84500-9	WIRE ASS'Y UL1007 #26 STR 450MM 2.0MM 2P RED	
N401	H01-WG02SB82200-1	WIRE ASS'Y UL1007#26 STR 220MM 2.0MM 2P RED	
	H01-WG02SG84800-A	WIRE ASS'Y UL1617#22 STR 480MM 7.92/3.96MM 2P WHT	
3SA-3151US-OUAA-1-1 AC ESABD IAA OUT BD DPR2005			
D401 402	H01-DG1N04148NB-4	D-SLP 1N4148 100.0V 150E-3A	
R401 402	RC3DI0330IN-7	RESISTOR CARBON FILM 33 OHM 1/4W 5%	
FH41 42	H01-SOP1FEHDDN-9	TERMFUSEHLDR FUSE-HOLDER J4210020001X	
3SA-3151US-OUMI-1-3 AC ESABD IMA REMOTE BD DPR2005			
BK51 52	H01-ZMC12S16A00-A	BKT GROUND	
C514	CCZID0104NA-2	CC 100NOF +80% -20% 50.0V F	
P501	H01-WN10SB00000-0	CONNECT 2.0MM 10P GIL-S-10P-S2T2-EF	
F501	H01-FURN2200006-6	FUSE T 2A 250V 7.6X8.6 SS-5 SAVE FUSETECH	
IC51 52 53	H01-ICPC17T10B1-2	IC PHOTOCOUPLER PC-17T1 DIP4 KODENSHI	
NJ51 52 53	H01-SOJW2350SNN-A	JACK PHONE 3.6 EP-1401A 1P BK	
NJ54	SO0A18P8CNN-7	JACK-TELE SNAP-IN GOLDEN TELECOM GDL1-8P8C 8T BK 0 0	
R515	3SA-3151US-OUAA-1-1 AC ESABD IAA REMOTE BD DPR2005	RCF 100R0 OHM +5% 250MI0W	
C502	3SA-3151US-OUAR-1-3 AC ESABD IAR REMOTE BD DPR2005	CEHFC01075E-1	
C501	H01-CEHIC0107AH-9	CE 100UF +20% 16.0V D6.3XL11 P5MM 85C	
Q501 502 503	H03-TRKTA107MNA-2	CE 100UOF +20% 50.0V 85C SHL	
C503 504 505 506	3SA-3151US-OUST-1-A AC ESABD SMD REMOTE BD DPR2005	TR-SLPSWA KRA107M P	
C512 513	CZJII0101BE-2	CCCFMIC 100P0F +5% -5% 50.0V NP0 0603	
C511 D511 512	CZZFI0104BF-8	CAP CHIP 100NOF +80% -20% 16.0V Y5V 0603	
D503 504 505 506	RS3AD0000NA-0	RMGCFMIC 0 OHM +0% 62MI5W	
L501 502	H01-DS1S50094NB-A	D-SLP 1SS355 35.0V 225MI0A	
R503	H01-FB2K52012NN-5	FBEAD SURFACE MT 2500OHM FCM2012H-252T02	
R507 508	RS3AD0271NA-2	RMGCFMIC 270R0 OHM +5% 62MI5W	
R510 511	RS3AD0392NA-1	RMGCFMIC 3K9 OHM +5% 62MI5W	
R501 502 521 522	RS3AD0470NA-7	RMGCFMIC 47R0 OHM +5% 62MI5W	
R504 505 506	RS3AD0471NA-5	RMGCFMIC 470R0 OHM +5% 62MI5W	
R509	RS3AD0472NA-3	RMGCFMIC 4K7 OHM +5% 62MI5W	
	RS3AD0104NA-A	RMGCFMIC 100K0 OHM +5% 62MI5W	
3SA-3151US-POMI-1-3 AC EMBD IMA PROCESSOR BD DPR2005			
BK72	PBD04KPOB20-A	PCB DUAL DPR2005 PRO 244MM*327MM*1.6t FR-4	
C437	H01-ZMD03S09A00-1	BRACKET SHIELD POWER	
P13	CEZXA0479MN-5	CM 47MI0F +80% -20% 5.5V 70C	
P11 12	H01-WN06SB01000-9	CNT PLUG BD'BD PLUG 2.0mm 35336-0610 6P	
P9	H01-WN11SB00000-8	CONN 2.0MM 11P MA ST NAT MOLEX 35336-1110 0 0	
P7	H01-WN13SB00000-2	CONN 2.0MM 13P GIL-S-13P-S2T2	
P10	H01-WN04SB00000-3	CONN 2.0MM 4 MA ST NAT GT201-4P-TS	
P3	H01-WN07SB00001-9	CONN 2.0MM 7P GIL-S-7P-S2T2-EF	
P14	H01-WN17SI00000-5	CONN FFC 1.25MM 17P SCB-1117-00-2 VER	
P5	H01-WN13S100000-6	CONN FFC 1.25MM SCB-1113-00-2 13P VER	
P4	H01-WN12SB100WH-7	CONN WAFER 2.0MM 12P 35336-1210 WHT	
P6	H01-WN10SD100WH-0	CONNECT WAFER 2.5MM 10 5267-10A 10P WHT	
Y1	H01-WN08SB100WH-4	CONNECT WFER 2.0MM 8P 35336-0810 WHT	
IC21	H01-OSCN120MOCU-6	CSTLS20MOX51-B0	
IC54	H01-ICNJM4556B2-7	IC OP AMP NJM4556AD DIP8	
NJ1	H03-ICKA78R08I2-A	IC-KA78R08API TO-220IS-4PIN	
NJ15 5	H01-SORA40GNDNN-7	JACK RCA 4P JB040131PN WWR	
NJ16 6	H01-SORA40RSCNN-A	JACK RCA 4P JB040131QN WH BU RD GY	
NJ2 3 4	H01-SORA40RSANN-6	JACK RCA 4P JB040131ZN GN BN PP TA	
	H01-SORA64105NN-5	JACK RCA 6P JB060132PN	

REF NO.	PARTS NO.	DESCRIPTION	TYPE
Y2	H01-OSCEM12M2RU-9	OSCILLATOR 12.288MHz 3.3V	
FG1 2 3 4 6 7 8	H01-ZMB01S02200-9	SPRING PLATE GND C5212 0.2T	
N2	H01-WS3262105FN-9	WIRE ASS'Y 2.0MM 3P 210MM UL2547#26 RED STR	
W100	H01-WC1220305C1-0	WIRE ASS'Y UL1007 #22 TC30MM 1P BLK	
N1	H01-WS0263805FN-6	WIRE ASS'Y UL2547/1007#26 380MM 2.0MM 10P RED	
	3SA-3151US-POAA-1-1	AC ESABD IAA PROCESSOR BD DPR2005	
L3 5 6	H01-LAINB047ACR-3	LF 4U7H +10% 1.7 OHM 190.0A	
R431 440 500 509	RC3DI0181IN-9	RCF 180 OHM +5% 250MI0W	
D15 16	H01-DR1N04004NA-1	D-SR 1N4004 400.0V 1.0A	
L1 13	H01-LA1340470NN-4	INDUCTOR COIL AL04TB470K 47UH 1.34OHM	
L7	H01-DG1N04148NB-4	D-SLP 1N4148 100.0V 150E-3A	
	3SA-3151US-POAR-1-3	AC ESABD IAR PROCESSOR BD DPR2005	
C10 102 103 111 119	CEHFC01062S-0	CE 10UF +20% 16V D4XL7 P2.5MM 2000hours 85C	
120 128 129 13 133			
134 139 14 140 147			
148 149 150 151 152			
159 160 161 162 173			
176 185 186 191 192			
193 194 197 198 199			
200 212 215 216 219			
226 229 244 245 339			
342 343 345 346 347			
348 349 350 351 352			
368 369 371 372 377			
378 384 385 386 387			
392 393 396 397 400			
409 417 445 446 449			
452 469 470 483 489			
490 491 500 505 520			
521 522 525 526 546			
547 556 557 560 561			
566 567 570 571 73 74			
77 78 79 80 83 84 85			
86 89 9 90 91 92 95			
96 579			
C122 131 136 138 177	CEHFC01072S-9	CE 100UF +20% 16V D6.3XL7 P2.5MM 2000hours 85C	
20 203 21 27 277 280			
281 293 294 3 323 324			
353 424 456 461 463			
464 468 473 475 482			
494 495 501 508			
C125 126 137 142 145	CEHFC04762S-0	CE 47UF +20% 16V D5XL7 P2.5MM 2000hours 85C	
155 157 163 165 167			
170 171 174 175 18 19			
195 196 222 225 248			
249 276 279 287 288			
299 300 305 306 311			
312 317 318 329 330			
335 336 358 359 364			
365 370 383 388 403			
404 426 447 459 492			
499 545 558 559 562			
563 568 569 75 76 81			
82 87 88 93 94			
C523	CEHIC01042S-5	CE 100NF +20% 50V SSE TYPE D4XL7 P2.5MM 85C	
C123 127 498	CEHIC01055E-6	CE 1UF +20% 50V D5XL11 P5MM 85C	
C113 114 534	H01-CEHIC0225AH-5	CE 2U2F +20% 50.0V 85C 5X11 SHL	
C830	CEMFC0226NN-9	CAP ELEC 22UF 16V M ELITE	
Q38	H03-TRMPSA06NNA-A	TR-SLPLF MPESA06 N 500MI0A TO-92	
C549	H01-CEMFC0107MN-3	CE 100UF 16V M 5X11 SHL P2.5MM	
C573 574	CEMHC0107NN-3	CE 100UF 35V M 6.3X11	
C550 551 552 553 575	H01-CEMFC0477AH-A	CE 470UF 16V M 8X11.5 SHL	
576 577			
C253 254	H01-CEMFC0337NN-5	CE 330UF 16V M 8X11.5 SHL	
	3SA-3151US-POSB-1-4	AC ESABD SMD BOT PROCESSOR BD DPR2005	
C1 100 164 166 168	CZJII0101BE-2	CCCFMIC 100P0F +5% -5% 50.0V NPO 0603	
169 178 2 201 202 206			
207 211 213 214 217			
218 220 221 223 230			
231 232 233 236 237			
241 242 250 251 255			
259 29 30 31 32 33 34			
35 36 37 38 389 39			
399 40 405 41 410 419			
42 43 438 439 440 44			
45 46 47 472 477 48			
485 49 50 509 51 512			
511 513 514 52 527 53			
539 54 55 56 57 58 59			
60 61 62 63 64 65 66			
67 68 69 70 71 72 97			
98 99 587			

REF NO.	PARTS NO.	DESCRIPTION	TYPE
C106 107 108 109 11 110 118 12 15 16 183 184 189 190 22 23 240 243 269 270 420 423 548 564 565 572	CZJII0330BE-9	CCCFMIC 33P0F +5% -5% 50.0V NP0 0603	
C421 C143 144 156 158 C141 146 153 154 394 395	CZKII0122BC-1 CZKII0272BC-4 CZKII0561BC-8	CAP CHIP 1N2F +10% -10% 50.0V X7R 0603 CAP CHIP 2N7F +10% -10% 50.0V X7R 0603 CAP CHIP 560P0F +10% -10% 50.0V X7R 0603	
C130 135 204 205 208 209 210 224 24 246 247 25 252 256 257 26 260 261 262 263 264 265 266 271 272 28 425 427 428 429 430 431 433 434 435 436 441 442 443 444 448 450 451 453 454 455 457 471 474 479 480 481 497 5 502 504 510 517 518 519 524 528 530 531 533 537 554 555 818 907 908 915 916	CZZFI0104BF-8	CAP CHIP 100N0F +80% -20% 16.0V Y5V 0603	
C411 414 416 L12 17 2 22 28 30 4 D1 2 4 5 14 25 IC9 Q16 18 25 42 58 59 Q12 13 26 39 7 8 R632 638 641 642 653 656 659 660 692 693 696 699	CZKII0103BC-5 H01-FB3002012NN-4 H01-DS1S50094NB-A H01-ICTC9273NDA-0 H01-TRDTA114YNI-9 H03-TRKTD1304ND-0 RS1AD0303NA-9	CAP CHIP 10N0F +10% -10% 50.0V X7R 0603 FBEAD SURFACE MT 300OHM FCM2012V-301T07 D-SLP 1SS355 35.0V 225M10A IC-SWITCH TC9273F-004 SOP28 ANALOG SWITCH TR-SSD DTA114YKA P 10K0 OHM 47K0 OHM TR-SLPSWA KTD1304 N 20V 300M10A SOT-23 RES CHIP 30K OHM 1/16W 1% 0603	
C274 275 307 308 309 310 337 338 356 357 366 367	CZJII0271BE-A	CAP CHIP, 270PF 50V +/-5% CH J 0603	
C586 R443 513 592 594 595 596	CZKII0102BC-7 RS3AD0101NA-5	CAP CHIP 1N0F +10% -10% 50.0V X7R 0603 RMGCFMIC 100R0 OHM +5% 62MI5W	
R100 103 104 105 106 108 118 119 129 130 159 161 162 163 164 166 168 172 174 242 243 248 249 250 251 252 258 259 26 267 268 27 270 280 290 300 376 377 423 424 425 426 484 485 512 633 634 643 644 654 655 664 665 689 691 697 698	RS3AD0102NA-3	RMGCFMIC 1K0 OHM +5% 62MI5W	
R107 111 112 236 276 277 287 288 289 291 301 302 303 304 314 315 316 321 337 341 342 343 354 355 356 357 373 374 375 464 466 473 474 527 528 580 589 8 9 624 651	RS3AD0103NA-1	RMGCFMIC 10K0 OHM +5% 62MI5W	
R32 33 34 35 42 43 46 465 469 47 56 57 58 59 64 65 84 85 90 91	RS3AD0104NA-A	RMGCFMIC 100K0 OHM +5% 62MI5W	
R12 13 136 137 147 148 328 329 339 340 370 378 432 433 451 460	RS3AD0122NA-8	RMGCFMIC 1K2 OHM +5% 62MI5W	
R16 17 320 323 358 359 382 383	RS3AD0151NA-1	RMGCFMIC 150R0 OHM +5% 62MI5W	
C289 290 297 298 319 320 327 328 375 376 379 382	CZJII0181BE-0	CCCFMIC 180P0F +5% -5% 50.0V NP0 0603	
R603 604 611 613 R216 R124 128 139 140 418 430 588 R177 178 R176 179 470 471 R415 526 534	RS3AD0182NA-1 RS3AD0911NA-3 RS3AD0222NA-4 RS3AD0242NA-9 RS3AD0392NA-1 RS3AD0332NA-8	RES CHIP, 1.8K, 1/16W, +/-5%, 0603. RMGCFMIC 910 OHM +5% 62MI5W RMGCFMIC 2K2 OHM +5% 62MI5W RMGCFMIC 2K4 OHM +5% 62MI5W RMGCFMIC 3K9 OHM +5% 62MI5W RMGCFMIC 3K3 OHM +5% 62MI5W	

REF NO.	PARTS NO.	DESCRIPTION	TYPE
R224 246 247 260 261 265 266 274 275 30 31 36 37 38 39 40 41 44 45 48 49 52 53 54 55 60 61 62 63 66 67 86 87	RS3AD0471NA-5	RMGCFMIC 470R0 OHM +5% 62MI5W	
R167 2 229 4 5 529 530 531 549 570 571 673 675	RS3AD0472NA-3	RMGCFMIC 4K7 OHM +5% 62MI5W	
R14 15 169 173 201 203 207 211 212 324 325 348 350 380 381 402 403 486 487 497 616	RS3AD0473NA-1	RMGCFMIC 47K0 OHM +5% 62MI5W	
R171 175 223 278 279 312 313 322 326 371 372 674 676	RS3AD0512NA-6	RMGCFMIC 5K1 OHM +5% 62MI5W	
R206 R24 25 R135 141 144 146 R227 C408 R623 650 R476 Q31 32 33 36 53 C373 374 380 381 390 398 422 432 465 466 486 487 506 507 529 532	RS3AD0682NA-3 RS3AD0912NA-1 RS3AD0562NA-2 RS3AD0221NA-6 RS3AD0302NA-6 RS3AD022ANA-7 H01-TRDTC114YNI-5 CZKII0182BC-5	RMGCFMIC 6K8 OHM +5% 62MI5W RMGCFMIC 9K1 OHM +5% 62MI5W RMGCFMIC 5K6 OHM +5% 62MI5W RMGCFMIC 220R0 OHM +5% 62MI5W RMGCFMIC 3K0 OHM +5% 62MI5W RMGCFMIC 2R2 OHM +5% 62MI5W TR-SSD DTC114YKA N 10K0 OHM 47K0 OHM CAP CHIP 1N8F 50V X7R K 0603	
D12 20 21 22 IC45 IC6 R605 606 610 614 C401 C460 467 C172	H01-DSUDZ05V1NB-4 H01-ICKIC9459D5-8 H01-ICLM02068D2-A RS1AD0153NA-2 RS3AD0100NA-7 CZKII0472BC-7 CZKII0223BC-6 3SA-3151US-POST-1-A CZJII0101BE-2	DIODE ZENER UDZ5.1B 5.1V 200MI0W IC-LOWFREQ KIC9459F SOP24 TONE/VOL/BAL/MUTE IC-OPERAMP NJM2068M DUAL SOP8 RES CHIP 15K OHM 1/16W 1% 0603 RMGCFMIC 10R0 OHM +5% 62MI5W CAP CHIP 4N7F 50V X7R K 0603 CAP CHIP 22N0F +10% -10% 50.0V X7R 0603 AC ESABD SMD TOP PROCESSOR BD DPR2005 CCCFMIC 100P0F +5% -5% 50.0V NP0 0603	
C17 238 239 258 462 515 516 541 580 581 582 583	CZJII0330BE-9	CCCFMIC 33P0F +5% -5% 50.0V NP0 0603	
C115 116 234 235 406 407 542 543 544	CZJII0680BE-4 CZKII0102BC-7	CAPACITOR CERAMIC CHIP 68PF 50V CH J NPO 0603 CAP CHIP 1N0F +10% -10% 50.0V X7R 0603	
C535 C291 292 295 296 321 322 325 326 354 355 540	CZKII0122BC-1 CZKGI0183BC-6 CZZFI0104BF-8	CAP CHIP 1N2F +10% -10% 50.0V X7R 0603 CAP CHIP 18NF 25V +/-10% 0603 X7R CAP CHIP 100N0F +80% -20% 16.0V Y5V 0603	
C536 C538 C101 104 105 112 117 121 124 132 179 180 181 182 187 188 227 228 267 268 273 278 282 283 284 285 286 301 302 303 304 313 314 315 316 331 332 333 334 340 341 344 360 361 362 363 391 4 418 458 478 484 488 493 496 503 578 588 589 590 591 592 593 594 595 596 597 7 8 901 902 903 904 905 906 909 910 911 912 913 914 918 919			
D13 17 3 6 D18 19 23 24 L10 11 14 15 16 18 19 20 21 23 24 25 26 27 29 31 32 33 34 35 41 42 44 47 48 8 9	H01-DS1S50094NB-A H01-DSUDZ05V1NB-4 H01-FB3002012NN-4	D-SLP 1SS355 35.0V 225MI0A DIODE ZENER UDZ5.1B 5.1V 200MI0W FBEAD SURFACE MT 300OHM FCM2012V-301T07	
IC26 IC57 IC60 IC10 22 IC56 IC15 IC61 IC24 IC58 IC62 IC44 IC14 IC52	H01-IC49L8192I5-A H01-IC74LS05MD5-1 H01-IC74VC244G5-6 H01-ICAK05384DA-6 H01-ICBU4094BD3-2 H01-ICKIC9162DA-5 H01-ICCS42528EC-0 H01-ICCS4391AD8-5 H01-ICCS49400ED-3 H01-ICD703033E1-5 H01-ICDDX8228E6-5 H01-ICKIC9459D5-8 H01-ICK4S1616M6-9	IC-FLASH MEMORY ROM AT49LV8192A 70ns IC OPEN COLLECTOR INVER DM74LS05M SOP24 IC-LOGIC 74VHC244A INVERTER CMOS IC A/D CONVERTOR AK5384 SOP28 IC CMOS BU4094BF SOP16 IC-SWITCH KIC9162AF SOP28 ANALOG SWITCH IC-CODEC CS42528CQ IC CONV CS4391A-KZ SOP20 IC-DSP CS494003-CQ LQFP144 IC-MICOM FLASH NEC UPD70F3033BGF 0228KK001 JAPAN QFP100 IC MICOM DDX8228 TQFP64 IC-LOWFREQ KIC9459F SOP24 TONE/VOL/BAL/MUTE IC-SDRAM K4S161622E-TC70 OR TC80	

REF NO.	PARTS NO.	DESCRIPTION	TYPE
IC12 13 16 17 18 19 2 20 25 27 28 29 3 30 31 32 33 34 35 36 37 38 39 4 40 41 42 46 47 5 7 8	H01-ICLM02068D2-A	IC-OPERAMP NJM2068M DUAL SOP8	
IC55	H01-ICM24C04WD2-1	IC-EEPROM M24C04WMN6T	
IC43 48	H01-ICNC7SV17XX-4	IC NC7SV17	
C402 412 413 415 476	CZKII0103BC-5	CAP CHIP 10N0F +10% -10% 50.0V X7R 0603	
IC1	H01-ICNJM239133-A	IC-NJM2391DL1-33 LOW VOLTAGE	
IC70	H01-ICMM1662HI3-2	IC MM1662H LOW DROP VOLTAGE REGULATOR SOP-8	
IC11	H01-ICTC9273NDA-0	IC-SWITCH TC9273F-004 SOP28 ANALOG SWITCH	
Q11 14 15 17 21 44 47 48 51	H01-TRDTA114YNI-9	TR-SSD DTA114YKA P 10K0 OHM 47K0 OHM	
Q28 29 30 34 35 37 52	H01-TRDTC114YNI-5	TR-SSD DTC114YKA N 10K0 OHM 47K0 OHM	
Q1 10 19 2 20 22 23 24 27 3 4 40 41 43 45 46 49 5 50 54 55 56 57 6 9	H03-TRKTD1304ND-0	TR-SLPSWA KTD1304 N 20V 300MI0A SOT-23	
C584 585	RS3AD0000NA-0	RMGCFMIC 0 OHM +0% 62MI5W	
R446 459 462 463 475 492 577 578 579 612	RS3AD0100NA-7	RMGCFMIC 10R0 OHM +5% 62MI5W	
R10 11 115 116 117 121 122 132 152 153 154 156 157 158 184 185 188 189 192 193 200 202 21 210 218 22 225 226 23 230 233 237 238 281 282 285 286 305 306 308 311 327 331 332 333 334 335 336 338 361 362 366 367 368 369 394 395 397 398 404 405 406 407 413 414 428 429 438 453 454 455 456 457 458 461 478 479 482 502 523 550 551 559 560 561 562 563 564 565 566 569 587 590 615 622 627 629 631 647 652 663 666 679 680 7 700 72 73 78 79 88 89 94 95	RS3AD0101NA-5	RMGCFMIC 100R0 OHM +5% 62MI5W	
R1 120 123 145 150 253 254 255 439 442 445 447 448 505 506 507 508 520 521 522 546 547 548 568 575 582 6 617	RS3AD0102NA-3	RMGCFMIC 1K0 OHM +5% 62MI5W	
R412 467 493 496 503 504 514 515 518 532 535 538 540 541 542 543	RS3AD0103NA-1	RMGCFMIC 10K0 OHM +5% 62MI5W	
R125 126 155 160 18 180 181 186 187 19 190 191 196 197 198 199 208 209 213 214 215 222 239 240 318 319 360 363 384 385 392 393 396 401 408 409 410 417 436 437 449 450 519 583 584 585 586 618 619 620 625 626 628 636 637 648 649 661 662 671 672 68 69 713 714 74 75 76 77 82 83 92 93 98 99	RS3AD0104NA-A	RMGCFMIC 100K0 OHM +5% 62MI5W	
R411 420 422 552	RS3AD0151NA-1	RMGCFMIC 150R0 OHM +5% 62MI5W	
R101 142 143 149 151	RS3AD0512NA-6	RMGCFMIC 5K1 OHM +5% 62MI5W	
R498	RS3AD010ANA-6	RES, CHIP, 1, 1/16W, +/-5%, 0603	
R109 110 113 114 133 134 165 170 217 219 244 245 257 262 263 264 272 273 419 421 427 480 488 489 495 50 51 517 574 581 678	RS3AD0222NA-4	RMGCFMIC 2K2 OHM +5% 62MI5W	
R231 444 490 491 621 682	RS3AD022ANA-7	RMGCFMIC 2R2 OHM +5% 62MI5W	
R539	RS3AD0302NA-6	RMGCFMIC 3K0 OHM +5% 62MI5W	

REF NO.	PARTS NO.	DESCRIPTION	TYPE
R292 293 294 295 296 297 298 299 344 345 346 347 349 351 352 353 555 556 557 558	RS3AD0331NA-A	RMGCFMIC 330R0 OHM +5% 62MI5W	
R472 481 525 533 536 537 544	RS3AD0332NA-8	RMGCFMIC 3K3 OHM +5% 62MI5W	
R182 183 194 195 204 205 28 29 390 391 399 400 434 435 599 601 630 635 667 668 70 71 80 81 96 97	RS3AD0471NA-5	RMGCFMIC 470R0 OHM +5% 62MI5W	
R138 220 228 232 234 241 256 269 271 283 284 330 379 416 468 524 573 677	RS3AD0472NA-3	RMGCFMIC 4K7 OHM +5% 62MI5W	
R221 3 307 309 310 317 364 365 388 389 516	RS3AD0473NA-1	RMGCFMIC 47K0 OHM +5% 62MI5W	
R545	RS1AD3321NA-3	RES CHIP 3.32K OHM 1/16W 1% 0603	
R127 131	RS3AD0561NA-4	RMGCFMIC 560R0 OHM +5% 62MI5W	
R235	RS3AD0562NA-2	RMGCFMIC 5K6 OHM +5% 62MI5W	
R602 609	RS3AD047ANA-6	RES CHIP,4R7 1/16W +/-5%,0603.	
RS1 3 4 5	RS3AY0103NA-7	RCA 10K0 OHM +5% 62MI5W 4	
RS10 11 12 13 14 6 7 8 9	RS3AY0470NA-2	RCA 47R0 OHM +5% 62MI5W 4	
R102 499 591 600 607 608 639 640 645 646 657 658 669 670 685 687 694 695	RS3AD0432NA-4	RMGCFMIC 4K3 OHM +5% 62MI5W	
R386 387 510 511	RS3AD0910NA-5	RES CHIP 910HM 1/16W 5% 0603	
IC23 59	H01-IC74V244MG5-3	IC-LOGIC 74VHCT244A INVERTER CMOS	
R441 572	RS3AD0202NA-A	RMGCFMIC 2K0 OHM +5% 62MI5W	
R553 554 593 597 598 567 576	RS3AD0221NA-6	RMGCFMIC 220R0 OHM +5% 62MI5W	
C851	CZJII0471BE-2	CCCFMIC 470P0F +5% -5% 50.0V NP0 0603	
R452 494	RS3AD0121NA-A	RMGCFMIC 120R0 OHM +5% 62MI5W	
RS2	RS3AY0332NA-3	RCA 3K3 OHM +5% 62MI5W 4	
R477	RS3AD0470NA-7	RMGCFMIC 47R0 OHM +5% 62MI5W	
R483	RS3AD0750NA-1	RMGCFMIC 75R0 OHM +5% 62MI5W	
C603	CSDIE040ABG-1	CAP CHIP FORM,4P +-0.25P,50V,0603,COG.	
C602	CEHFC01062S-0	CE 10UF +20% 16V D4XL7 P2.5MM 2000hours 85C	
C601	CCZID0104NA-2	CC 100NOF +80% -20% 50.0V F	
R20	RC3DI0222IN-A	RCF 2K2 OHM +5% 250MI0W	
3SA-3151US-POMI-1-3		AC EMBD IMA PWR SW BD DPR2005	
P821	H01-WN02SE00000-6	CON 3.96MM PITCH HEADER 2 POS MOLEX 35328-0210	
P820	H01-WN02SB00000-9	CONN 2.0MM 2 MA ST NAT GT201-2P-TS	
SW80	H01-SWE4A21PDA%-5	SWITCH POWER SDKVB10100 5A 250V 4P	
3SA-3151US-VDMI-1-9		AC EMBD IMA VIDEO BD DPR2005	
	PBD04KVDI20-5	DPR2005 VIDEO SINGLE PCB 194MM*219MM*1.6t FR-1 1OZ	
P102	H01-WN13SB00000-2	CONN 2.0MM 13P GIL-S-13P-S2T2	
P101	H01-WN12AB00000-8	CONN WAFER 2.0MM 12P 35237-1210 WHT	
P100	H01-WN08AB100WH-7	CONNECT WAFER 2.0MM 8P 35237-0810 WHT	
Y100	H01-OSXBEL14M3AU-7	CRYSTAL 14.31818MHZ WOOIN	
Y101	H01-OSXBEL17M7AU-9	CRYSTAL 17.734475MHZ WOOIN	
IC32	H03-ICKIA7806I2-4	IC KIA7806AP VOLTQAGE REGULATOR TO-220AB	
NJ19	H01-SORA90173NN-6	JACK RCA 9P JB090173FN	
NJ10 11 12 13 14 15 16 17	H01-SORA11Y00NN-5	JACK RCA+S VIDEO C5016031DN	
SK10 11	H01-RLL0517811A-A	RELAY D3009(1-1462033-4)	
SK10 11	H03-RLL0517811A-5	RELAY D3009(1-1462033-4)	
3SA-3151US-VDAA-1-7		AC ESABD IAA VIDEO BD AXIAL DPR2005	
D102 104	H01-DG1N04148NB-4	D-SLP 1N4148 100.0V 150E-3A	
L100 101 102	H03-FB05B3580NN-7	BEAD AXIAL/TAP,HC3580 80.5ohm	
L107	H01-LALNB056ACR-A	INDUCTOR COIL AL02TB5R6J 5.6UH 1.9OHM +5%	
L104 105 106 108 110	H01-LAINB0470CR-2	LF 47UOH +10% 5.8 OHM 500MI0A	
3SA-3151US-VDAR-1-9		AC ESABD IAR VIDEO BD DPR2005	
C104 106 107 109 115 117 122 124 125 127 155 156 163 165 220 244 248 252 263	CEHEC02275E-9	CE 220UF +20% 10.0V D6.3XL11 P5MM 85C	
C269	CEHIC01065E-4	CE 10U0F +20% 50.0V 85C P5MM 5X11	
C149 150 151 152 157 158 159 160 161 162 166 167	CEHEC0477MN-A	CE 470U0F +20% 10.0V 6.3X11 85C ELITE	
C105 108 112 116 123 126 164 183 186 191 238 247 251 264	H01-CEHFC0106AH-5	CE 10U0F +20% 16.0V 85C AH SAMYOUNG	
C188 193 198 229 231 233 236 239 242 245 249 266 267 268	CEHFC01075E-1	CE 100UF +20% 16.0V D6.3XL11 P5MM 85C	

REF NO.	PARTS NO.	DESCRIPTION	TYPE
C102 215	CEMFC0226NN-9	CAP ELEC 22UF 16V M ELITE	
C154 172 174 179 222 235 241	CEHF04765E-3	CE47UF +20% 16.0V D5XL11 P5MM 85C	
C195 204 208 213	CEHIC01055E-6	CE 1UF +20% 50V D5XL11 P5MM 85C	
C185 189	H01-CEHIC0225AH-5	CE 2U2F +20% 50.0V 85C 5X11 SHL	
C205	CEHIC0474NN-9	CE 470N0F +20% 50.0V 85C 5X11 ELITE	
C194	CPIC0223NN-4	CPF 22N0F +10% 50.0V	
C196	CPIC0682NN-5	CPF 6N8F +10% 50.0V	
Q101 104 114 116	H01-TR2SA933ANW-2	TR-SLPLF 2SA933ASR P -3.0A -20V	
Q100 117	H01-TR2SC1740NW-9	TR-SLPLF 2SC1740S R N 150M10A 50V	
Q115	H03-TRMP5A56YNA-0	TR-SLPLF MP5A56 Y P -500M10A -300V	
	3SA-3151US-VDST-1-5	AC ESABD SMD VIDEO BD DPR2005	
C200	CZEII0100BE-0	CCCFMIC 10P0F +0P5F -0P5F 50.0V NPO 0603	
C100 101 103 110 111 114 118 119 121 153 168 169 170 175 176 177 180 181 182 209 210 211	CZJII0101BE-2	CCCFMIC 100P0F +5% -5% 50.0V NPO 0603	
C202	CZJII0270BE-1	CCCFMIC 27P0F +5% -5% 50.0V NPO 0603	
C201	CSJIE0300BG-2	CAP,CHIP FORM 30P +/-5% 50V C0G 0603	
C203 206 207 214	CZJII0390BE-2	CAP CHIP 39PF 50V CH J NPO 0603	
C228	CZJII0181BE-0	CCCFMIC 180P0F +5% -5% 50.0V NPO 0603	
C184 187 192 197 199	CZKII0103BC-5	CAP CHIP 10N0F +10% -10% 50.0V X7R 0603	
C227	CZKII0561BC-8	CAP CHIP 560P0F +10% -10% 50.0V X7R 0603	
C171 173 178 221 225 226 232 234 237 240 243 246 250	CZZFI0104BF-8	CAP CHIP 100N0F +80% -20% 16.0V Y5V 0603	
C190	CZKII0223BC-6	CAP CHIP 22N0F +10% -10% 50.0V X7R 0603	
D100 101 103 106 107	H01-DS1S50094NB-A	D-SLP 1SS355 35.0V 225M10A	
IC19 28	H01-ICBU4053BB4-7	IC BU4053BCF SOP16 ANALOG MPX/DEMPX	
IC29 30 31	H01-ICBU4094BD3-2	IC CMOS BU4094BF SOP16	
IC33	H01-ICLC74763I4-1	IC OSD LC74763M SOP30	
IC13 14 26	H01-ICMM1501XDL-A	IC-VIDEO SW MM1501XNRE SOT-26B	
IC16 17 18	H01-ICNJM2296D3-7	IC-LINEAR NJM2296	
IC27	H01-ICTSH95IDB4-6	IC-VIDEOPROC TSH95ID VIDEO AMPLIFIER	
Q102 103	H01-TRDTA114YNI-9	TR-SSD DTA114YKA P 10K0 OHM 47K0 OHM	
Q105 106 107 110 111 113	H01-TRDTC114YNI-5	TR-SSD DTC114YKA N 10K0 OHM 47K0 OHM	
R136 137 138 140 141 142 144 145 146 160 180 190 191 192 195 200 239	RS3AD0102NA-3	RMGCFMIC 1K0 OHM +5% 62MI5W	
R147	RS3AD0104NA-A	RMGCFMIC 100K0 OHM +5% 62MI5W	
IC15	H01-ICMM1511XDL-8	IC-VIDEO SW MM1511XNRE SOT-26B	
R182	RS3AD0101NA-5	RMGCFMIC 100R0 OHM +5% 62MI5W	
R100 104 105 112 117 118 122 126 127 158 159 163 165 179 199 201 210 211 212 213 214 215 238	RS3AD0103NA-1	RMGCFMIC 10K0 OHM +5% 62MI5W	
R185 188	RS3AD0105NA-8	RES CHIP 1M 1/16W +5% 0603	
R186 187 197	RS3AD0121NA-A	RMGCFMIC 120R0 OHM +5% 62MI5W	
R162 166 167	RS3AD0122NA-8	RMGCFMIC 1K2 OHM +5% 62MI5W	
R139 143	RS3AD0123NA-6	RMGCFMIC 12K0 OHM +5% 62MI5W	
R202	RS3AD0124NA-4	RMGCFMIC 120K0 OHM +5% 62MI5W	
D108 109 110 111 112 113 114 115 116 117	H03-DS05GBUSCNB-5	DIODE PG05GBUSC	
R196	RS3AD0152NA-A	RMGCFMIC 1K5 OHM +5% 62MI5W	
R168 194	RS3AD0154NA-6	RMGCFMIC 150K0 OHM +5% 62MI5W	
R181	RS3AD0221NA-6	RMGCFMIC 220R0 OHM +5% 62MI5W	
R206 207	RS3AD0222NA-4	RMGCFMIC 2K2 OHM +5% 62MI5W	
R153 161 164 240	RS3AD0223NA-2	RMGCFMIC 22K0 OHM +5% 62MI5W	
R203	RS3AD0224NA-0	RMGCFMIC 220K0 OHM +5% 62MI5W	
R150 152	RS1AD1580NA-0	RES CHIP 1580HM 1% 1/16W 0603	
IC10 11 12	H01-ICMM1510XDL-7	IC-VIDEO SW MM1510XNRE SOT-26A	
R154	RS3AD0431NA-6	RES CHIP,430 OHM,1/16W,+/-5%,0603	
R241	RS3AD0180NA-5	RES CHIP 18 OHM 1/16W +/-5% 0603.	
R149	RS3AD0331NA-A	RMGCFMIC 330R0 OHM +5% 62MI5W	
R205 208	RS3AD0333NA-6	RMGCFMIC 33K0 OHM +5% 62MI5W	
R217 218 219 220 221 222 223 224 226 227 228 229 230 231 232 233 234 235 236	RS3AD010ANA-6	RES, CHIP, 1, 1/16W, +/-5%, 0603	
R155 156	RS3AD0430NA-8	RMGCFMIC 43R0 OHM +5% 62MI5W	
R176	RS1AD0471NA-A	RESISTOR CHIP 470OHM 1/16W 1% 0603	
R177	RS1AD0511NA-2	RES CHIP 510OHM 1% 1/16W 0603	
R193	RS3AD0513NA-4	RMGCFMIC 51K0 OHM +5% 62MI5W	
R204 209	RS3AD0680NA-7	RMGCFMIC 68R0 OHM +5% 62MI5W	
R198	RS3AD0682NA-3	RMGCFMIC 6K8 OHM +5% 62MI5W	

REF NO.	PARTS NO.	DESCRIPTION	TYPE
R101 102 103 106 107 108 109 110 111 119 120 121 128 129 130 131 132 133	RS1AD0750NA-6	RES CHIP 75OHM 1% 1/16W 0603	
R225	RS3AD0820NA-6	RMGCFMIC 82R0 OHM +5% 62MI5W	
R169	RS3AD0822NA-2	RMGCFMIC 8K2 OHM +5% 62MI5W	
R113 114 115 116 123 124 125	H01-RS1AD78R7NA-9	RES CHIP 78.7OHM 1% 1/16W 0603	
C230	CEHFC01075E-1	CE 100UF +20% 16.0V D6.3XL11 P5MM 85C	

COMPLETE SMPS POWER SUPPLY PCB ASS'Y - PART# H01-ZVD04001300-8

COMPLETE TUNER MODULE(USA) - PART# H01-ZVD03TUNE00-9

DPR1005/2005 SMPS (Power Supply) Electrical Parts List

NOTE: Ordinarily the DPR1005/2005 SMPS Power Supply module is supplied only as a complete unit. Supplied Schematic and Parts list are included only for reference when the above part is not available and/or repair to component level is necessary. For h/k part number equivalents, contact harman/kardon at 516-255-4545 ext. 6553

		DPR2005US		DPR1005US				
Description		location/designator	Q/ty	location/designator	Q/ty	VENDOR1	VENDOR2	remarks
P.C.B	KJP-10013US	400*164	1			DUSAN		Black coating
P.C.B	KJP-10013EU	400*164				DUSAN		
P.C.B	KJP-7013EU	400*164				DUSAN		
P.C.B	KJP-7013US	400*164			1	DUSAN		
IC	KA1M0880B-DTU	U101	1	U101	1	FAIRCHILD		TO-3P
IC	KA431Z	U201	1	U201	1	FAIRCHILD		TO-92
IC	KA7805	U204	1	U204	1	FAIRCHILD		TO-220
IC	S1117-50PI	U202	1	U202	1	AUK		TO-220
IC	KA7905	U207	1	U207	1	FAIRCHILD		TO-220
IC	KIA7812	U205	1	U205	1	KEC		TO-220
IC	KA7815	U208	1	U208	1	FAIRCHILD		TO-220
IC	KA7818	U203	1	U203	1	FAIRCHILD		TO-220
IC	KA7912	U206	1	U206	1	FAIRCHILD		TO-220
MOS-FET	FQA30N40	Q102.103.104.105	4			FAIRCHILD		TO-3P
MOS-FET	IRFP350			Q102.103.104.105	4	IR		
TR	KTN2222A(KSP2222A)	Q201	1	Q201	1	Yoosuck	FAIRCHILD	TO-92
TR	C1008	Q101,202.204	3	Q101,202.204	3	FAIRCHILD	KEC	
TR	A708	Q203.205	2	Q203.205	2	FAIRCHILD	KEC	
PHOTO COUPLER	ET1103	PC101.102	2	PC101.102	2	VISHAY		
BD DIODE	PBS2505G(PBS2506)	BD101	1	BD101	1	Daebo	LRC	
BD DIODE	DF06(600V1A)	BD201,BD202	2	BD201,BD202	2	Daebo	LRC	
SCH DIODE	31DQ06	D201,202	2	D201,202	2	NI		
SCH DIODE	31DF2	D204	1	D204	1	NI		
SCH DIODE	KCU30A30	D214.215	2			NI		
SCH DIODE	KCF25A20/KCH20A20			D214.215	2	NI		
SCH DIODE	HER204	D203,205,206,216,217	5	D203,205,206,216,217	5	SungHo		
SW DIDDE	1N4148	D102.218.219,220.221.222.223,224	8	D102.218.219,220.221.222.223,224	8	SungHo		
UF DIODE	UF4004	D101.104.207	3	D101.104.207	3	SungHo		
DIODE	1N4007	D212.213	2	D212.213	2	SungHo		
UF DIDDE	UF4007	D103	1	D103	1	SungHo		
ZN DIDDE	1N4744(1W 15V)	ZD101.102.103.104	4	ZD101.102.103.104	4	SungHo		
ZN DIDDE	1N4754					SungHo		
ZN DIDDE	1N5231(1/2W 5V)	ZD201	1	ZD201	1	SungHo		
LINEAR TRANS	33*41(TPW4101)	T101	1	T101	1	WooJin elecom		
LINEAR TRANS	33*41(TPW4102)					WooJin elecom		
TRANSFORMER	EE5555(KJP-10013 T1)	T103	1			Kyusan Telecom		
TRANSFORMER	EE5555(KJP-7013T1)			T103	1	Kyusan Telecom		
TRANSFORMER	EER3541(KJP-10013 T2)	T102	1			Kyusan Telecom		
TRANSFORMER	EER3541(KJP-7013T2)			T102	1	Kyusan Telecom		
MULTI COIL	MPP 47PHI(10013MC)	L206	1			Kyusan Telecom		
MULTI COIL	MPP 47PHI(7013MC)			L206	1	Kyusan Telecom		

DPR1005/2005 SMPS (Power Supply) Electrical Parts List							
		DPR2005US		DPR1005US			
TOROIDAL	IRON13 ϕ	T203	1	T203	1	Kyusan Telecom	
TRANSFORMER	EE1927(KJP-10013 T3)	T201,202	2			Kyusan Telecom	
TRANSFORMER	EE1927(KJP-7013 T3)			T201,202	2	Kyusan Telecom	
LINE FILTER	38PHI(15T*15T)	LF101.LF102	2			WooJin elecrom	
LINE FILTER	38PHI(19T*19T)			LF101.LF102	2	WooJin elecrom	
BAR CORE	OB5x22mm MIN 6uH	L201.202.203,204.205	5	L201.202.203,204.205	5	Kyusan Telecom	
DRUM CORE	14*20 8mH	L207	1	L207	1	Kyusan Telecom	
BEED	L3550	L101	1	L101	1	Kyusan Telecom	
BOX CAP-	AC275V 105	C101,C103	2			PILKO	
BOX CAP-	AC275V 474	C102	1	C101.102.103	3	PILKO	SUNIL
CERAMIC CAP-	Y1 101	C125,126	2	C125,126	2	DONGIL	DAEMYOUNG
CERAMIC CAP-	Y1 102	C120,127,128	3	C120	1	DONGIL	DAEMYOUNG
CERAMIC CAP-	Y1 222	C104,105,119	3			DONGIL	DAEMYOUNG
	Y1 152			C104.105.119.127.128	5	DONGIL	DAEMYOUNG
CERAMIC CAP-	Y1 471					DONGIL	DAEMYOUNG
CERAMIC CAP-	1KV102	C201.202.241.242	4	C201.202.241.242	4	DONGIL	DAEMYOUNG
CERAMIC CAP-	2KV 221	C118	1	C118	1	DONGIL	DAEMYOUNG
DISK CERMIC CAP-	50V 104	C110.112.231.232,233.234.235 C237.238.239.244,245,246,247,250	15	C110.112.231.232,233.234.235 C237.238.239.244,245,246,247,250	15	DONGIL	DAEMYOUNG
CERAMIC CAP-	50V 103	C251,252	2	C251,252	2	DONGIL	DAEMYOUNG
CERAMIC CAP-	50V 102	C254	1	C254	1	DONGIL	DAEMYOUNG
CERAMIC CAP-	50V 101	C253	1	C253	1	DONGIL	DAEMYOUNG
GP CAP-	DC63V105	C243.248.C249	3	C243.248.C249	3	PILKO	
GP CAP-	DC63V224	C114.115.116.117	4	C114.115.116.117	4	PILKO	
NP-CAP	630V 472 (10m/m)	C109	1	C109	1	SuLuyng	
PP CAP-	250V 4.7 μ F	C121	1	C121,	1	SuLuyng	
AL,CAPACITOR	105 $^{\circ}$ C 10V 470uF KMG	C221,226,229	3	C221,226,229	3	SAMYOUNG	
AL,CAPACITOR	105 $^{\circ}$ C 10V 1000uF KMG	C204,C213	2	C204,C213	2	SAMYOUNG	
AL,CAPACITOR	105 $^{\circ}$ C 10V 2200uF KMG	C203	1	C203	1	SAMYOUNG	
AL,CAPACITOR	105 $^{\circ}$ C 16V 470uF KMG	C217	1	C217	1	SAMYOUNG	
AL,CAPACITOR	105 $^{\circ}$ C 16V 1000uF KMG	C225	1			SAMYOUNG	
AL,CAPACITOR	105 $^{\circ}$ C 16V 2200uF KMG	C212,215	2	C212,215	2	SAMYOUNG	
AL,CAPACITOR	105 $^{\circ}$ C 25V 220uF KMG	C219	1	C219	1	SAMYOUNG	
AL,CAPACITOR	105 $^{\circ}$ C 25V 1000uF KMG	C205.206,214.216,227	5	C205.206,214.216,227.225	6	SAMYOUNG	
AL,CAPACITOR	105 $^{\circ}$ C 35V 470uF KMG	C108,209	2	C108,209.218	3	SAMYOUNG	
AL,CAPACITOR	105 $^{\circ}$ C 35V 1000uF KMG	C208	1	C208	1	SAMYOUNG	
AL,CAPACITOR	105 $^{\circ}$ C 35V 2200uF KMG	C207	1	C207	1	SAMYOUNG	
AL,CAPACITOR	105 $^{\circ}$ C 50V 1uF KMG	C113	1	C113	1	SAMYOUNG	
AL,CAPACITOR	105 $^{\circ}$ C 50V 47uF KMG	C111	1	C111	1	SAMYOUNG	
AL,CAPACITOR	105 $^{\circ}$ C 63V 100uF KMG	C210,211	2	C210,211	2	SAMYOUNG	
AL,CAPACITOR	105 $^{\circ}$ C 63V 47uF KMG	C228	1	C228	1	SAMYOUNG	
AL,CAPACITOR	105 $^{\circ}$ C 63V 2200uF KMG	C222.223.224	3			SAMYOUNG	
AL,CAPACITOR	105 $^{\circ}$ C 50V 2200uF KMG			C222.223.224	3	SAMYOUNG	
AL,CAPACITOR	85 $^{\circ}$ C 200V 2200uF SMK	C106.107	2			SAMYOUNG	
	85 $^{\circ}$ C 200V 1200uF SMK			C106.107	2	SAMYOUNG	
AL,CAPACITOR	85 $^{\circ}$ C 16V 2200uF SHL	C220	1	C220	1	SAMYOUNG	
AL,CAPACITOR	85 $^{\circ}$ C 50V 470uF SHL	C218	1			SAMYOUNG	
VARISTER	14D471					HL	
M.O.R RESISTOR	1W 1.5	R123	1	R123	1	DI-Electronics	Hanbu

DPR1005/2005 SMPS (Power Supply) Electrical Parts List

		DPR2005US		DPR1005US			
M.O.R RESISTOR	1W 22	R213.214	2	R213.214	2	DI-Electronics	Hanbu
M.O.R RESISTOR	1W 100K	R106,107,109®	3	R106,107,109®	3	DI-Electronics	Hanbu
M.O.R RESISTOR	1W 220K	R108®	1	R108®	1	DI-Electronics	Hanbu
M.O.R RESISTOR	2W 4.7K	R203	1	R203	1	DI-Electronics	Hanbu
CEMENT RESISTER	5W 470®	R122	1	R122	1	DI-Electronics	Hanbu
CEMENT RESISTER	10W 2.2K®	R215,R216.217.218,219	5			DI-Electronics	Hanbu
CEMENT RESISTER	10W 1.5K®			R215,R216.217.218,219	5	DI-Electronics	Hanbu
Wire wound resistor	5W 15	R104,105	2	R104,105	2	DI-Electronics	Hanbu
VARIABLE RESISTER	5K	VR201,202	2	VR201,202	2	DI-Electronics	Hanbu
CARBON RESISTOR	1/2W 10K 5%	R204®	1	R204®	1	DI-Electronics	Hanbu
CARBON RESISTOR	1/2W 820K 5%	R112	1	R112	1	DI-Electronics	Hanbu
CARBON RESISTOR	1/2W 1M 5%	R102	1	R102	1	DI-Electronics	Hanbu
CARBON RESISTOR	1/4W 4.7 5%	R223	1	R223	1	DI-Electronics	Hanbu
CARBON RESISTOR	1/4W 10 5%	R201,202	2	R201,202	2	DI-Electronics	Hanbu
CARBON RESISTOR	1/4W 22 5%	R114,116,118,120	4	R114,116,118,120	4	DI-Electronics	Hanbu
CARBON RESISTOR	1/4W 47 5%	R111	1	R111	1	DI-Electronics	Hanbu
CARBON RESISTOR	1/4W 82 5%					DI-Electronics	Hanbu
	1/4W 100 5%	R110	1	R110	1	DI-Electronics	Hanbu
CARBON RESISTOR	1/4W 330 5%	R207	1	R207	1	DI-Electronics	Hanbu
CARBON RESISTOR	1/4W 1K 5%	R205,210	2	R205,210	2	DI-Electronics	Hanbu
CARBON RESISTOR	1/4W 100K 5%	R206	1	R206	1	DI-Electronics	Hanbu
CARBON RESISTOR	1/4W 3.9K 5%	R115,117,119,121	4	R115,117,119,121	4	DI-Electronics	Hanbu
CARBON RESISTOR	1/4W 4.7K 5%	R211,224	2	R211,224	2	DI-Electronics	Hanbu
CARBON RESISTOR	1/4W 47K 5%	R113	1	R113	1	DI-Electronics	Hanbu
CARBON RESISTOR	1/8W 220 5%			R221	1	DI-Electronics	Hanbu
CARBON RESISTOR	1/8W 330 5%	R222	1			DI-Electronics	Hanbu
CARBON RESISTOR	1/8W 1K 5%	R220	1	R222	1	DI-Electronics	Hanbu
CARBON RESISTOR	1/8W 2K 5%			R220	1	DI-Electronics	Hanbu
CARBON RESISTOR	1/8W 2.7K 5%			R225	1	DI-Electronics	Hanbu
CARBON RESISTOR	1/8W 680 5%	R221	1			DI-Electronics	Hanbu
CARBON RESISTOR	1/8W 4.7KF 1%	R225	1			DI-Electronics	Hanbu
METAL RESISTOR	1/4W 4.7KF 1%	R208,209	2	R208,209	2	DI-Electronics	Hanbu
FUSE	250V T20A(65TS)	F101	1			LITTLE FUSE	
FUSE	250V T8A(65TS)					LITTLE FUSE	
FUSE	250V T12A(65TS)			F101	1	LITTLE FUSE	
FUSE	218010(250V10A)					LITTLE FUSE	
FUSE CRIP	FC61B	F101,101	2	F101,101	2	LITTLE FUSE	
FUSE CRIP	D502					LITTLE FUSE	
HEATSINK	70*70*65H*6T	HS101	1	HS101	1	Jindo	Black coating
HEATSINK	15*11T*35H	HS106,107,108,109,7	5	HS106,107,108,109,7	5	SamKwang	Black coating
HEATSINK	47*16T*50H	HS103	1	HS103	1	SamKwang	Black coating
HEATSINK	39*12T*65H	HS105	1	HS105	1	SamKwang	Black coating
HEATSINK	140*101*78H-A(KJP10013)	HS102	1			Jindo	Black coating
HEATSINK	KJP7013A			HS102	1	Jindo	
HEATSINK	140*101*78H-B(KJP10013)	HS104	1			Jindo	Black coating
HEATSINK	KJP7013B			HS104	1	Jindo	
CONNECTOR-HDR	YW025-11P	CN201	1	CN201	1	Yunho	
CONNECTOR-HDR	YW025-10P	CN202	1	CN202	1	Yunho	
CONNECTOR-HDR	YW025-2P	CN204	1	CN204	1	Yunho	

DPR1005/2005 SMPS (Power Supply) Electrical Parts List

		DPR2005US		DPR1005US			
CONNECTOR-HDR	35313-0810 8PIN	CN203	1	CN203	1	MOLEX	
CONNECTOR-HDR	VL6.2mm 3PIN	CN101	1	CN101	1	JST	
RELAY	ALE15B12	RL101	1	RL101	1	NAIS	
JUMPER	6mm	J109	1	J109	1		
JUMPER	7.5mm	J17	1	J17	1		
JUMPER	10mm	J102,103,111,1,2,7,8,10,11,16	10	J102,103,111,1,2,7,8,10,11,16	10		
JUMPER	11mm	J108,22	2	J108,22	2		
JUMPER	12.5mm	J4,9,12,13,14,15,18,19,20,21,26	11	J4,9,12,13,14,15,18,19,20,21,26	11		
JUMPER	15mm	J110,3,24	3	J110,3,24	3		
JUMPER	17.5mm	J106,107,5,25	4	J106,107,5,25	4		
JUMPER	20mm	J104,105,J6,23	4	J104,105,J6,23	4		
JUMPER	22.5mm	J101	1	J101	1		
PAD RUBBER	TO3P	U101.D214.215.Q102.103.104.105	7	U101.D214.215.Q102.103.104.105	7		
BOLT	3x12mm		8		8	HanYang	
BOLT	3x10mm		7		7	HanYang	
BOLT	3x10mm(T/T)		9		9	HanYang	
BOLT	3x8mm		7		7	HanYang	
BOLT	4x10mm		3		3	HanYang	
Lug terminal			11		11		
BACKLITE	8*7.5*54L(M3 HOLE 3*1)		2		1		
	SUB PCB						
PCB	CEM1(48*51)		1		1	DUSAN	
IC	KA3525	U1	1	U1	1	FAIRCHILD	
IC	HA17393	U2	1	U2	1	HITACHI	FAIRCHILD
TR	KA2222	Q1.2	2	Q1.2	2	YooSuck	FAIRCHILD
DIODE	1N4148	D2	1	D2	1	SungHon	
DIODE	1N5234	D1	1	D1	1	SungHon	
DISK CERAMIC CAP	50V 104	C1.3.4.10.11	5	C1.3.4.10.11	5	DONGIL	
GP CAP	63V 104	C13	1	C13	1	PILKO	
MYLER CAP	100V 223	C6	1	C6	1	SoLyung	
MYLER CAP	100V 152	C7.9	2	C7.9	2	SoLyung	
AL-CAP	105°C 35V 47uF()	C2.5.8	3	C2.5.8	3	SAMYONG	
AL-CAP	105°C 50V 4.7uF()		1		1	SAMYONG	
CARBON RESISTOR	1/4W 100 5%	R18	1	R18	1	DI-Electronics	Hanbu
CARBON RESISTOR	1/8W 10 5%	R16.17	2	R16.17	2	DI-Electronics	Hanbu
CARBON RESISTOR	1/8W 22 5%	R14	1	R14	1	DI-Electronics	Hanbu
CARBON RESISTOR	1/8W 2.2K 5%	R5.6	2	R5.6	2	DI-Electronics	Hanbu
METAL RESISTOR	1/8W 4.7K 5%	R7.11	2	R7.11	2	DI-Electronics	Hanbu
CARBON RESISTOR	1/8W 22K 5%	R10	1	R10	1	DI-Electronics	Hanbu
CARBON RESISTOR	1/8W 82KF 1%	R12	1			DI-Electronics	Hanbu
	1/8W 62KF 1%			R12	1	DI-Electronics	Hanbu
METAL RESISTOR	1/8W 4.7KF 1%	R4,8,9,13	4	R4,8,9,13	4	DI-Electronics	Hanbu
CARBON RESISTOR	1/8W 6.8KF 1%	R15	1	R15	1	DI-Electronics	Hanbu
METAL RESISTOR	1/8W 10KF 1%	R3	1	R3	1	DI-Electronics	Hanbu
METAL RESISTOR	1/8W 9.1KF 1%	R2	1	R2	1	DI-Electronics	Hanbu
METAL RESISTOR	1/8W 100KF 1%	R1	1	R1	1	DI-Electronics	Hanbu
CONNECTOR-BD IN	5267-2Pin	CN2	1	CN2	1	Molex	
CONNECTOR-BD IN	YFAW254-7Pin		1		1		
CONNECTOR-BD IN	YFAW254-10Pin		1		1		

IC BLOCK DIAGRAMS

1.M74HCU04
 DSP PART IC701.702

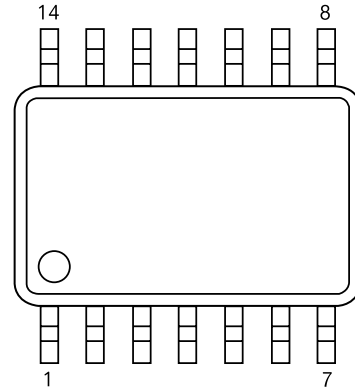
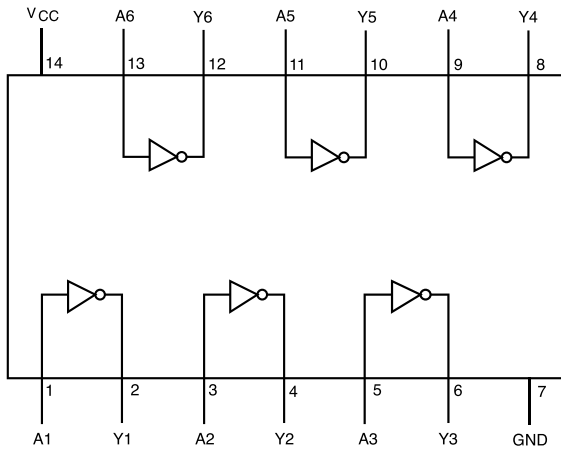

2.CS42528
 DSP PART IC700

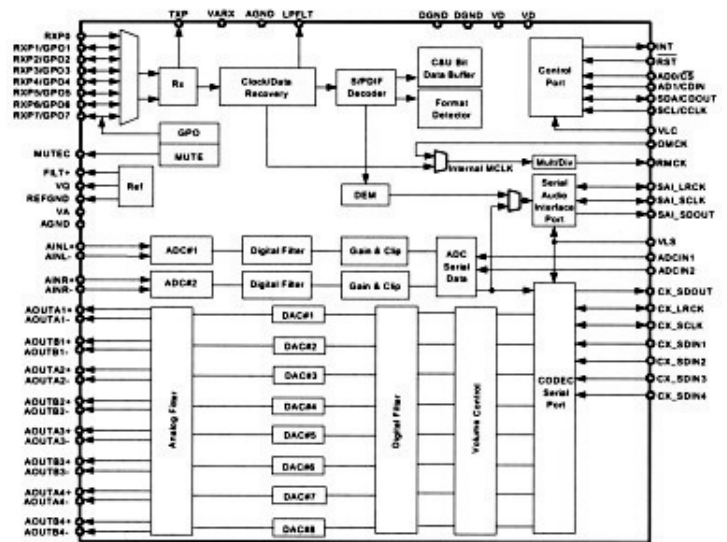
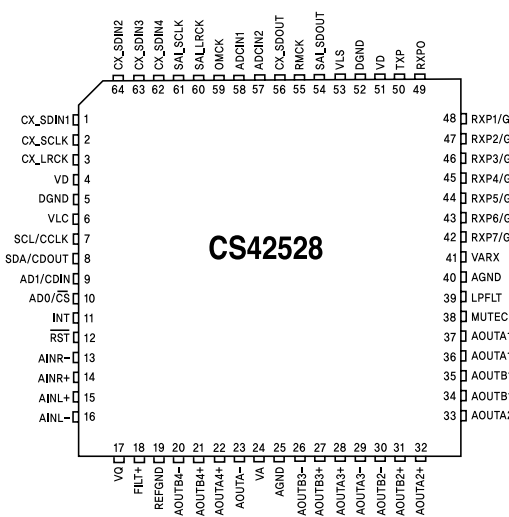

TC9273F

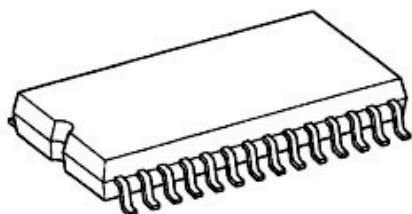

SOP28-P-450-1.27

4.TOTX179L
 DSP PART NJ76

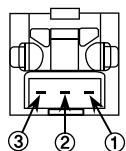

- Pin connection
- 1. Output
 - 2. GND
 - 3. Vcc

Fiber optic connector insertion side

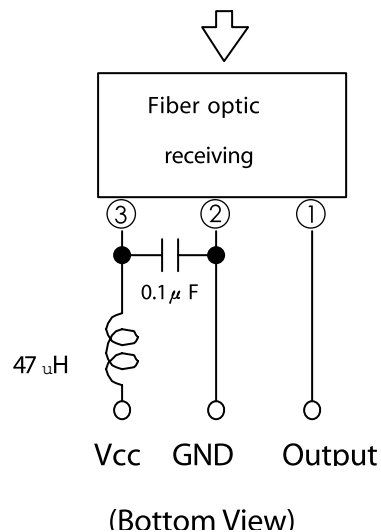

TORX179L
 DSP PART NJ74.NJ75
 SUPPLY PART NJ79

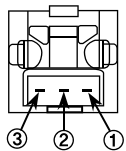

- Pin connection
- 1. GND
 - 2. Vcc
 - 3. Input

Fiber optic connector insertion side

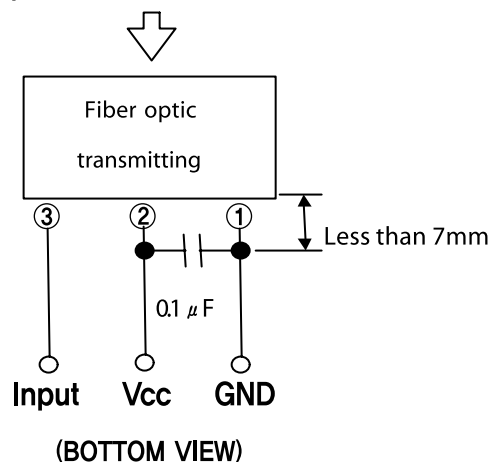

5.NJM6324
DSP PART

IC803

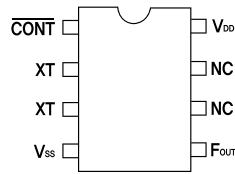

NJU6324XE

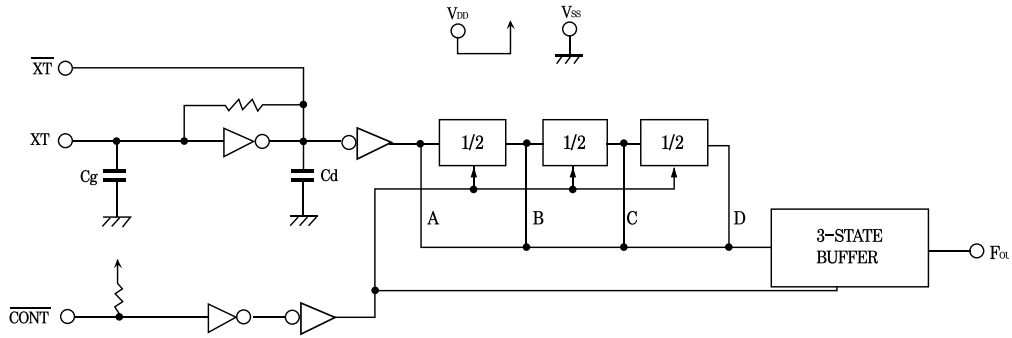

6.NJM4566AM
PROCESSOR PART

IC22

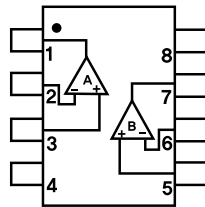

NJM4566AM

NJM4566AD
NJM4566AM
NJM4566AV

7.AT492V8192A
DSP PART

IC804

AT49BV/LV8192A(T) TSOP Top View
Type 1

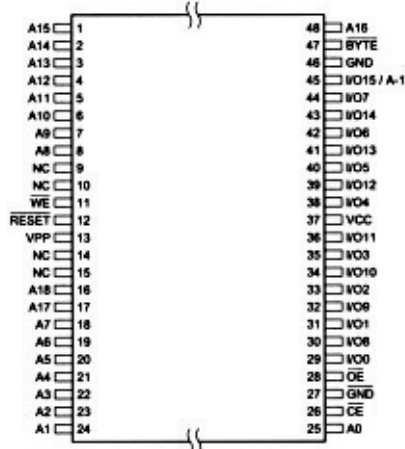

AT49BV/LV8192A(T) Block Diagram

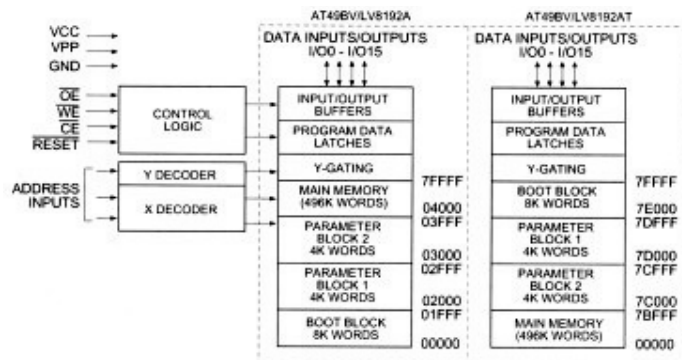

8.UPD70F3033BG
DSP PART

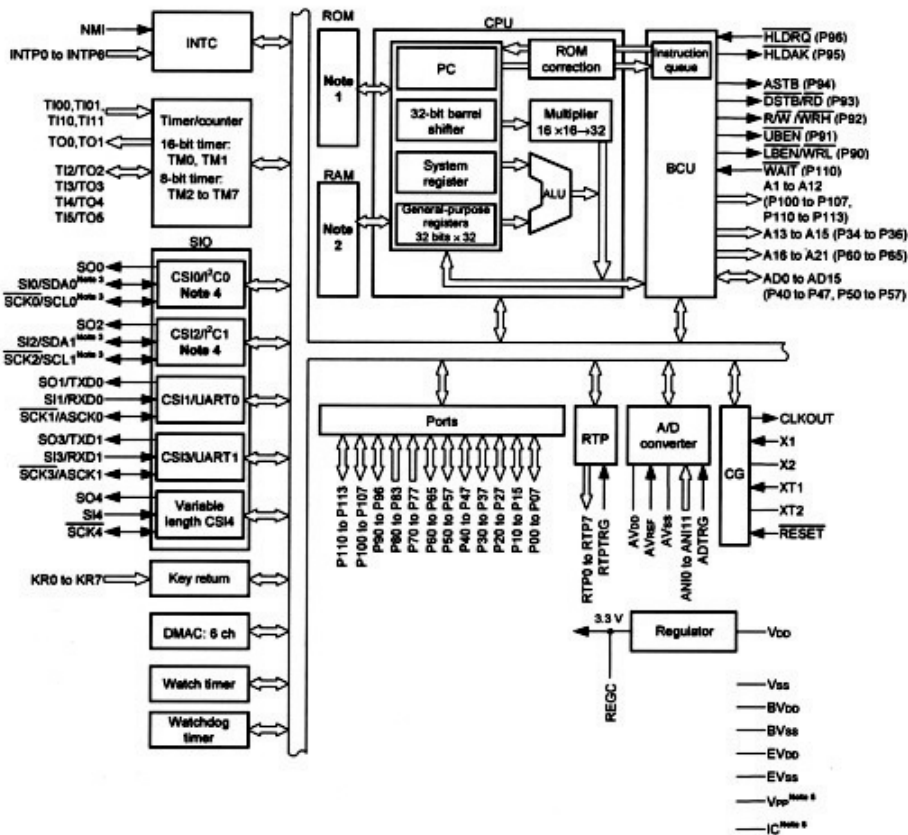
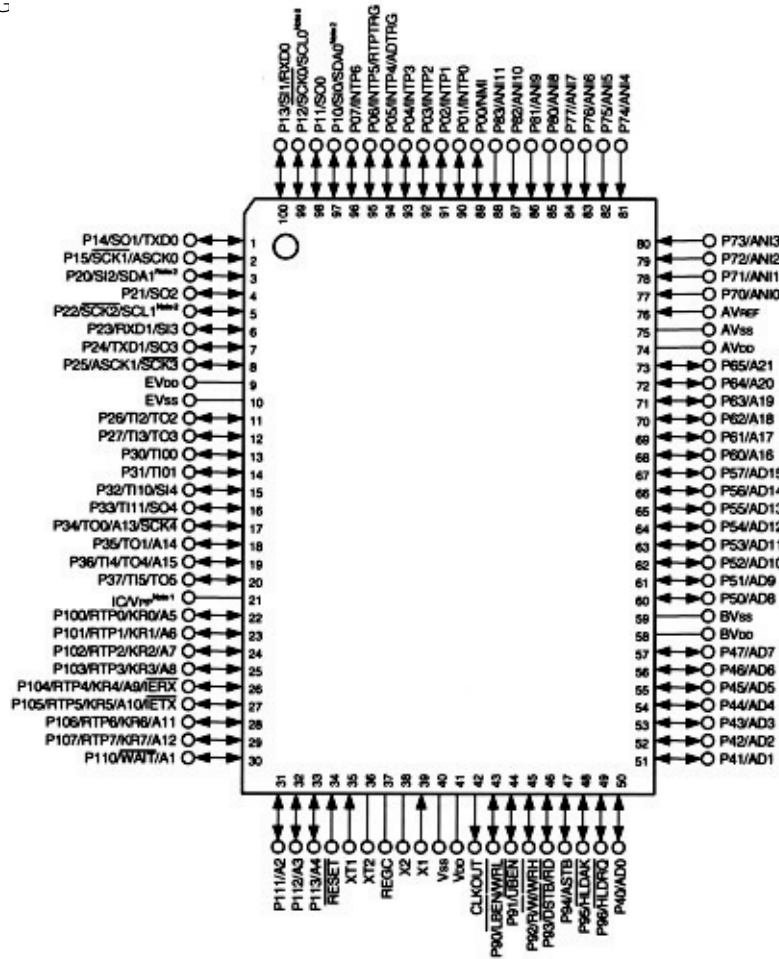

DPR1005/2005 MICOM PORT ASSIGN

PIN	V850 NAME	RECEVIER NAME	IN/OUT	Discription
1	P14/SO1/TXD0	RS-232 TX	OUT	UART TX PORT
2	P15/SCK1/ASCK0	VPP_CONTROL	OUT	VPP CONTROL FOR FLASH UPGRADE
3	P20/SI2/SDA1	D2AUDIO -RST	OUT	D2AUDIO RESET
4	P21/SO2			6dB VOLUME UP FOR HDCD
5	P22/SCK2/SCL1	FL STB	OUT	FL RESET
6	P23/RXD1/SI3	FL BLK	IN	FL DATA IN
7	P24/TXD1/SO3	FL DI	OUT	FIP DATA OUT
8	P25/ASCK1/SCK3	FL CLK	OUT	FIP DRIVER IC CLOCK OUT
9	EVDD	EVDD	POWER	VDD
10	EVSS	EVSS	POWER	GND
11	P26/TI2/TO2	ADC RESET	OUT	ADC RESET
12	P27/TI3/TO3	CODEC_RESET	OUT	CS42528, CS4391A RESET
13	P30/TI00	RMC_IN	IN	REMOCON IN
14	P31/TI01	CODEC_CE	OUT	CS42528, CS4391A CHIP ENABLE
15	P32/TI10/S14	RMC_MULTI	IN	MULTI ROOM REMOCON
16	P33/TI11/SO4	CODEC_CLK	OUT	CS42528 CHIP CLK
17	P34/TO0/SCK4	CODEC_DATA_OUT	OUT	CS42528 DATA OUT
18	P35/TO1	CODEC_DATA_IN	IN	CS42528 DATA IN
19	P36/TI4/TO4	CODEC_INT	IN	CS42528 INT
20	P37/TI5/TO5			3.3V I2C IO SELECT (0:OUT, 1:IN)
21	IC/VPP	VPP	IN	7.8V AT FLASH WRITE
22	P100/RTP0/KR0	DSP_RESET	OUT	CS49400 RESET(DSP)
23	P101/RTP1/KR1	DSP_HINBSY	IN	CS49400 HINBSY(DSP)
24	P102/RTP2/KR2	DSP_INTERQ_AB	IN	CS49400 INTERQ_AB(DSP)
25	P103/RTP3/KR3	DSP_CLK_AB	OUT	CS49400 CLK AB
26	P104/RTP4/KR4	DSP_CE_AB	OUT	CS49400 CE AB
27	P105/RTP5/KR5	DSP_DATA_OUT_AB	OUT	CS49400 DATA OUT(DSP)
28	P106/RTP6/KR6	DSP_DATA_IN_AB	IN	CS49400 DATA IN(DSP)
29	P107/RTP7/KR7	DSP_INTERQ_C	IN	CS49400 INTERQ C(DSP)
30	P110/WAIT	DSP_CLK_C	OUT	CS49400 CLK C(DSP)
31	P111	DSP_CE_C	OUT	CS49400 CE C(DSP)
32	P112	DSP_DATA_OUT_C	OUT	CS49400 DATA OUT C(DSP)
33	P113	DSP_DATA_IN_C	IN	CS49400 DATA IN C(DSP)
34	/RESET	RESET	IN	LOW ACTIVE
35	XT1	XT1	IN	Pull_Down
36	XT2	XT2	OUT	OPEN
37	REGC	REGC	POWER	VDD
38	X2	Fx_OUT	OUT	20.00MHz RESONATOR
39	X1	Fx_IN	IN	20.00MHz RESONATOR
40	VSS	VSS	POWER	GND
41	VDD	VDD	POWER	5V

42	CLKOUT	CLKOUT	OUT	OPEN
43	P90/LBEN/WRL			NC
44	P91/UBEN			NC
45	P92/RW/WRH	HP MUTE	OUT	HEADPHONE MUTE
46	P93/DSTB/RD	I2C DATA	OUT	I2C-SDA (EEPROM, DDX8228, D2A)
47	P94/ASTB	I2C CLK	OUT	I2C-SCL (EEPROM, DDX8228, D2A)
48	P95/HLDAK	VOL ST	OUT	9459 VOLUME IC STROB
49	P96/HLDRQ	4094 CE	OUT	4094 CHIP ENABLE
50	P40	4094 CLK	OUT	4094 CLK
51	P41	4094 DATA	OUT	4094 DATA
52	P42	VOL DATA	OUT	9459 VOLUME IC DATA
53	P43	VOL CLK	OUT	9459 VOLUME IC CLK
54	P44	SEL DATA	OUT	9273, 9162 FUNCTION IC DATA
55	P45	SEL CLK	OUT	9273, 9162 FUNCTION IC CLK
56	P46	SEL ST1	OUT	9273_1 FUNCTION IC CHIP ENABLE
57	P47	SEL ST2	OUT	9273_2 CHIP FUNCTION IC ENABLE
58	BVDD	BVDD	POWER	VDD
59	BVSS	BVSS	POWER	GND
60	P50	T_MUTE	OUT	TUNER MUTE OUT
61	P51	TUNED	IN	TUNED CHECK IN
62	P52	T_CE	OUT	TUNER PLL IC(LC72131) CHIP ENABLE
63	P53	T_CLOCK	OUT	TUNER PLL IC(LC72131) CLOCK
64	P54	T_DATA IN/STEREO	IN	TUNER PLL IC(LC72131) DATA IN
65	P55	T_DATA OUT	OUT	TUNER PLL IC(LC72131) DATA OUT
66	P56	FMUTE	OUT	FRONT PREOUT MUTE
67	P57	CMUTE	OUT	CENTER PREOUTR MUTE
68	P60	SMUTE	OUT	SURROUND PREOUT MUTE
69	P61	SBMUTE	OUT	SURR BACK PREOUT MUTE
70	P62	SUBMUTE	OUT	SUB WOOFER MUTE
71	P63	PMUTE	OUT	D2A AMP POWER DOWN
72	P64	RECMUTE	OUT	REC MUTE
73	P65	MULTI MUTE	OUT	MULTI ROOM MUTE
74	AVDD	AVDD	POWER	VDD
75	AVSS	AVSS	POWER	GND
76	AVREF	AVREF	POWER	VDD
77	P70/ANI0	AD KEY1	ADIN	A/D KEY INPUT1
78	P71/ANI1	AD KEY2	ADIN	A/D KEY INPUT2
79	P72/ANI2			NC
80	P73/ANI3			NC
81	P74/ANI4	ENCODE1	IN	VOLUME ENCODER INPUT 1
82	P75/ANI5	ENCODE2	IN	VOLUME ENCODER INPUT 2
83	P76/ANI6	YC/COMP CHECK	ADIN	Y/C,COMPO jack check in
84	P77/ANI7	HP_IN	IN	HEADPHONE INPUT
85	P80/ANI8	STEP	IN	TUNER FREQ OPTION

86	P81/ANI9			NC
87	P82/ANI10	PROTECTION	IN	PROTECTION IN(Normal-high)
88	P83/ANI11			NC
89	P00/NMI	STANDBY	OUT	MAIN POWER ON/OFF
90	P01/INTP0	POWER DOWN	INTP0	POWER DOWN CHECK : RISING EDGE
91	P02/INTP1	RDS_CLOCK	INTP1	RDS_CLOCK
92	P03/INTP2	RDS_DATA	IN	RDS_DATA
93	P04/INTP3	COAX_INOUT SEL	IN	CS42528 MUTE
94	P05/INTP4/ADTRG	SYNC pluse check	IN	Pal,ntsc pulse width check
95	P06/INTP5/RTPTRG	Sync in/out check	IN	Sync in,off check
96	P07/INTP6	A19	OUT	AT49LV8192A A19
97	P10/SI0	OSD CE	OUT	OSD CHIP ENABLE
98	P11/SO0	OSD CLK	OUT	OSD CLK
99	P12/SCK0	OSD DATA	OUT	OSD DATA
100	P13/SI1/RXD0	RS-232 RX	RX	UART RX PORT

9. BU4094BCF
 DSP PART
 VIDEO PART
 FRONT PARRT

IC602
 IC19, IC20
 IC101

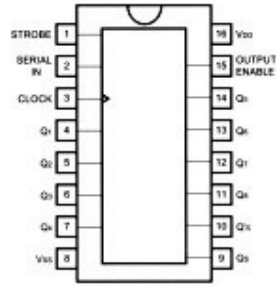
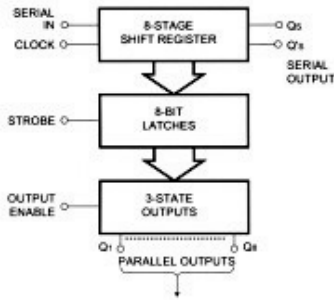

BU4094BCF

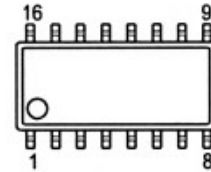

10. VCOX 24M576HZ
 DSP PART Y800

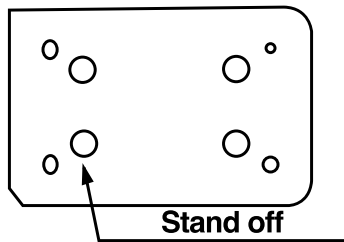
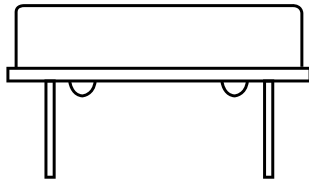

<14 PIN DIP>

PIN #	CONNECTION
# 1	INH or No Connection
# 7	Ground
# 8	Output
# 14	Vdc

11. BA033T
 MAIN PART

IC53

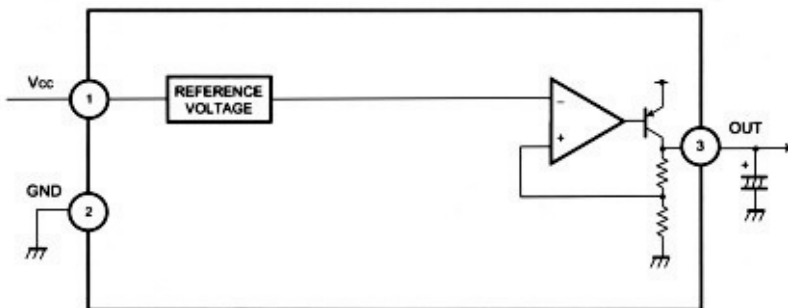

BAOOT Series

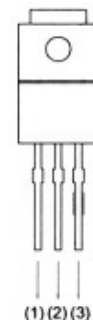

(1)Vcc
 (2)GND
 (3)OUT

TO220FP

12.NJM2296M
VIDEO PART
IC10.11.12

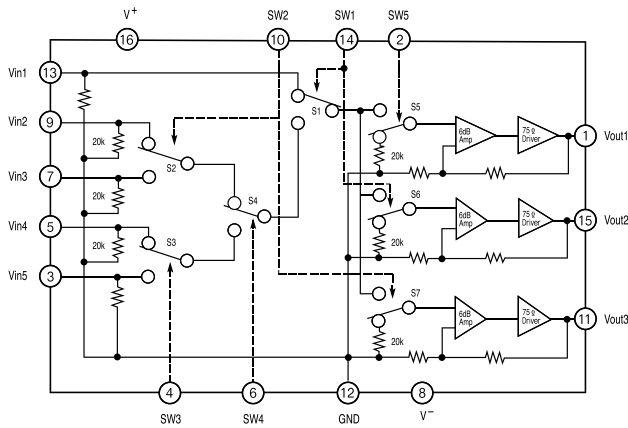

13.MM1505
VIDEO PART
IC13.15.23

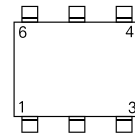
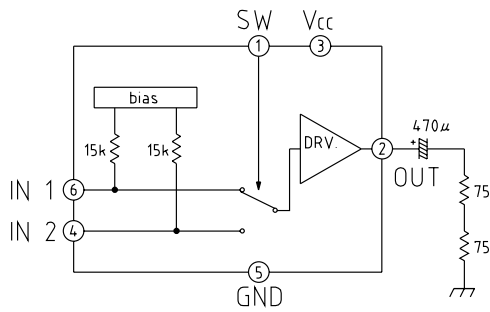

14.MM1501
VIDEO PART
IC14,25,26

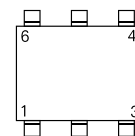
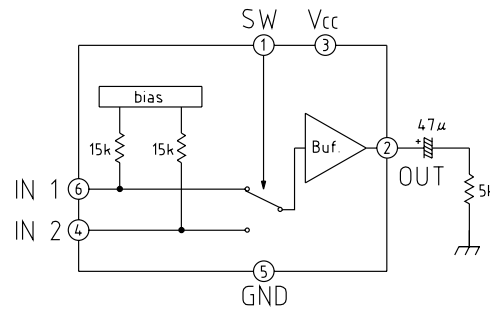

15.MM1511
VIDEO PART
IC27

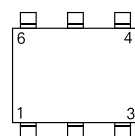
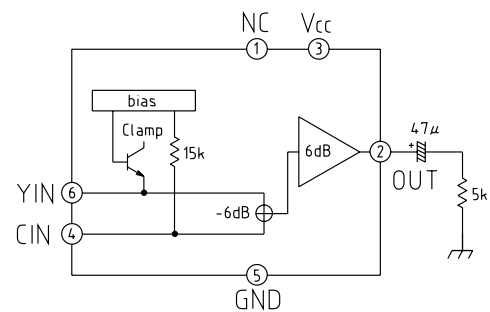

16.PHOTOCOUPLER PC-17T1
VIDEO PART

IC40.51.52

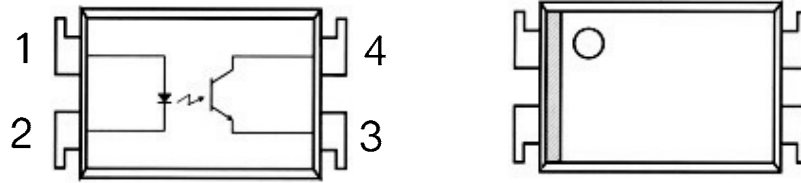

PIN Connections

- 1.Anode
- 2.Cathode
- 3.Emitter
- 4.Collector

17.TC9162AF PROCESSOR PART

IC14

PIN CONNECTION (TOP VIEW)

TC9162AF
TC9163AF
TC9164AF

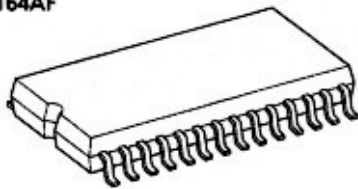

SOP28-P-450-1.27

TC9162AN/AF

V _{SS}	1	28	V _{DD}
L-S ₁	2	27	R-S ₁
L-S ₂	3	26	R-S ₂
L-COM ₁	4	25	R-COM ₁
L-S ₃	5	24	R-S ₃
L-S ₄	6	23	R-S ₄
L-COM ₂	7	22	R-COM ₂
L-S ₅	8	21	R-S ₅
L-S ₆	9	20	R-S ₆
L-COM ₃	10	19	R-COM ₃
L-S ₇	11	18	R-S ₇
L-COM ₄	12	17	R-COM ₄
ST	13	16	DATA
GND	14	15	CK

18.TC9163AF PROCESSOR PART

IC3

TC9162AF
TC9163AF
TC9164AF

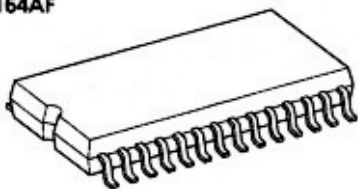

SOP28-P-450-1.27

TC9162AN/AF

V _{SS}	1	28	V _{DD}
L-S ₁	2	27	R-S ₁
L-S ₂	3	26	R-S ₂
L-COM ₁	4	25	R-COM ₁
L-S ₃	5	24	R-S ₃
L-S ₄	6	23	R-S ₄
L-COM ₂	7	22	R-COM ₂
L-S ₅	8	21	R-S ₅
L-S ₆	9	20	R-S ₆
L-COM ₃	10	19	R-COM ₃
L-S ₇	11	18	R-S ₇
L-COM ₄	12	17	R-COM ₄
ST	13	16	DATA
GND	14	15	CK

19.TC9482F
PROCESSOR PART IC19

TC9482F

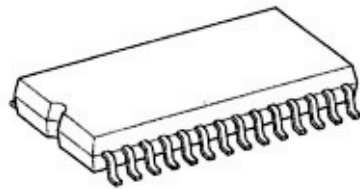

SOP28-P-450-1.27

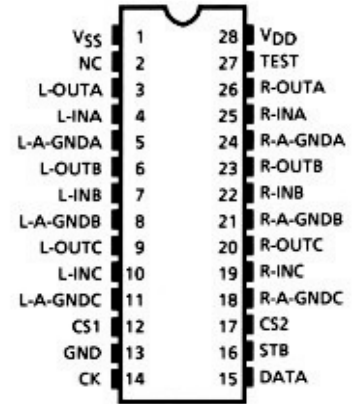

20.TC9481F
PROCESSOR IC28

TC9481F

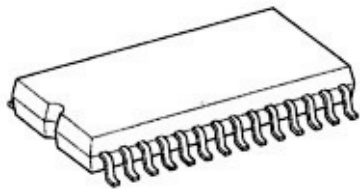

SOP28-P-450-1.27

TC9481F

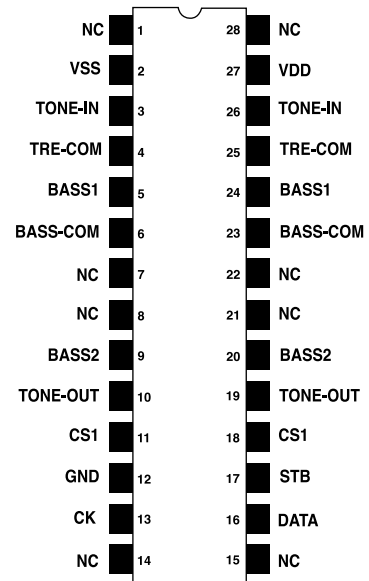

21.KIC9459F
PROCESSOR IC2, 18

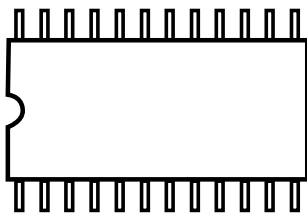

KIC9459F

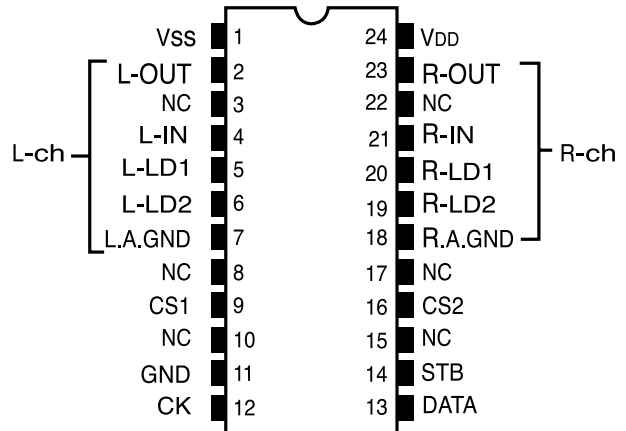

22.TSH95
VIDEO PART IC17

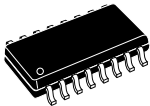

D
SO16
(Plastic Micropackage)

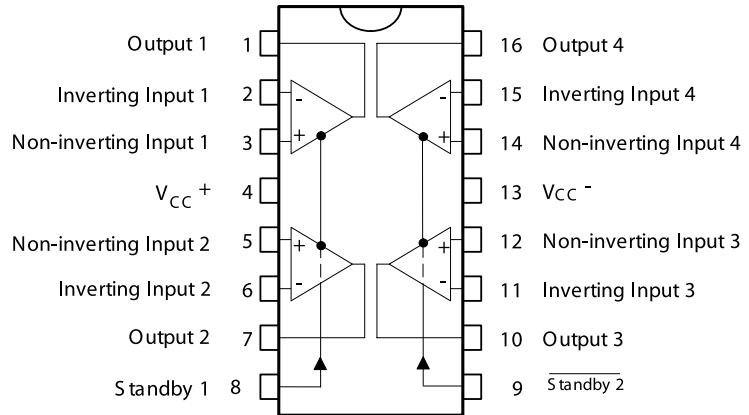

23.MPD4721
VIDEO PART IC50

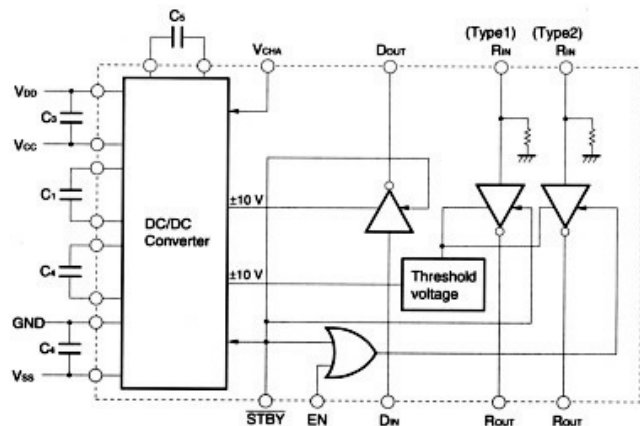
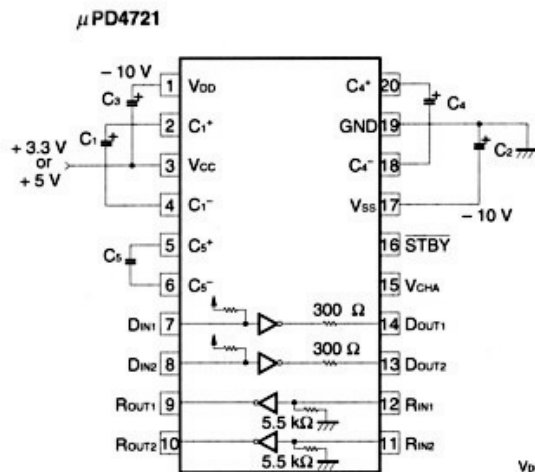

24.K4S161622D-TC80
 DSP PART IC805

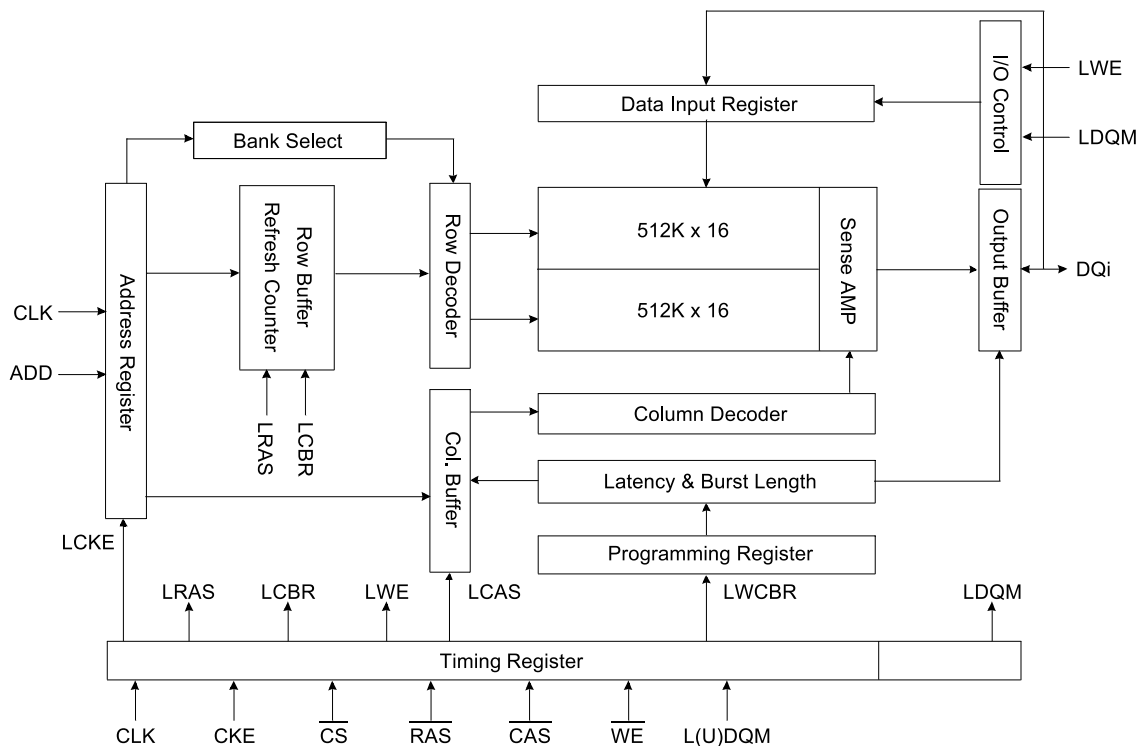
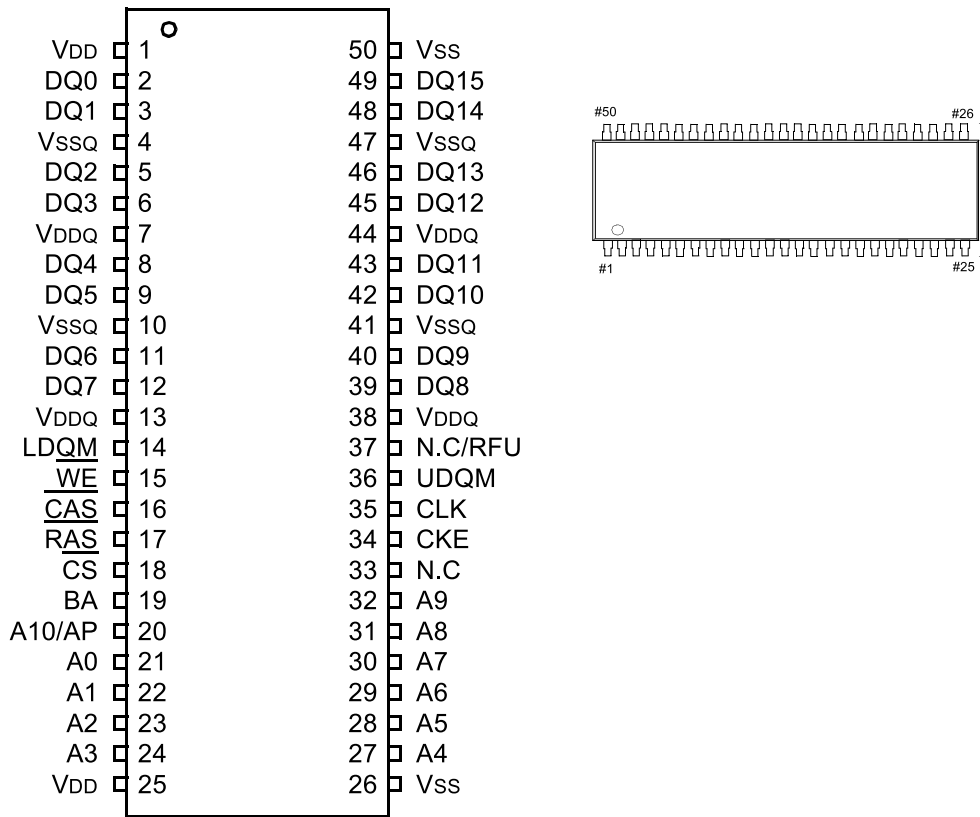

25.M24C04
DSP PART IC603

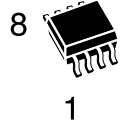
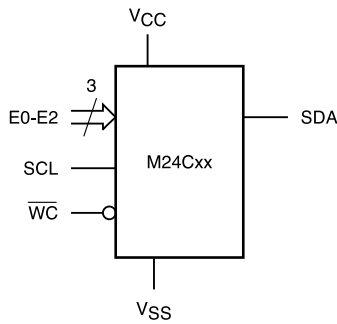

SO8 (MN)
150 mil width

E0, E1, E2	Chip Enable
SDA	Serial Data
SCL	Serial Clock
\overline{WC}	Write Control
VCC	Supply Voltage
VSS	Ground

M24Cxx

16Kb/8Kb/4Kb/2Kb/1Kb

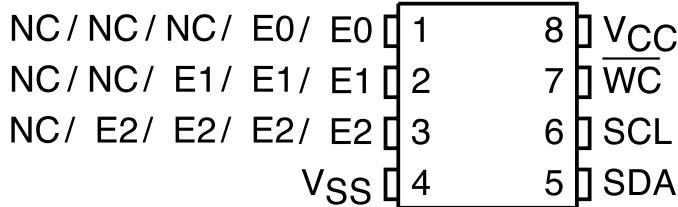

26.74VHC2441A
DSP PART IC802

74VHCT24A
DSP PART IC801

Connection Diagram

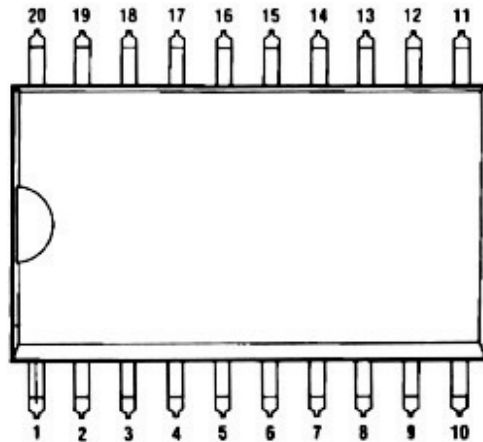
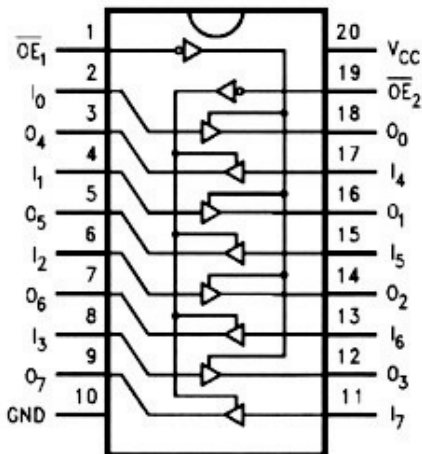

27.2C74763M
VIDEO PART

IC22

System Block Diagram

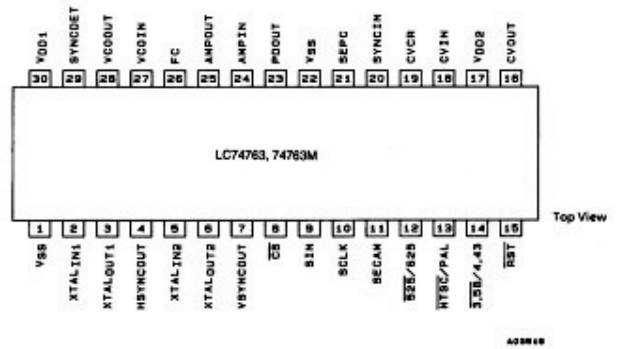
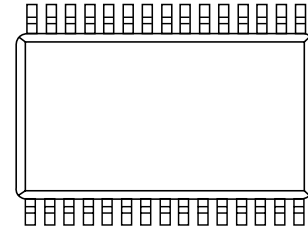
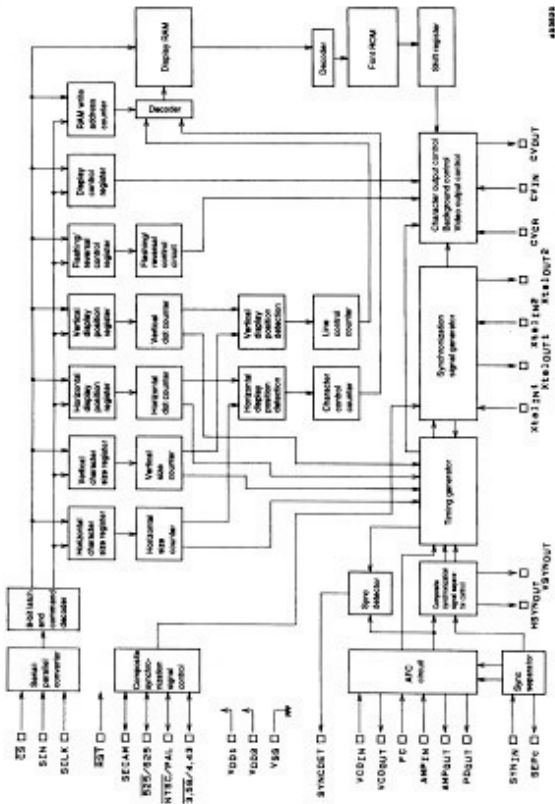

28.FL
HCA-18LL03
FRONT PART

DP10

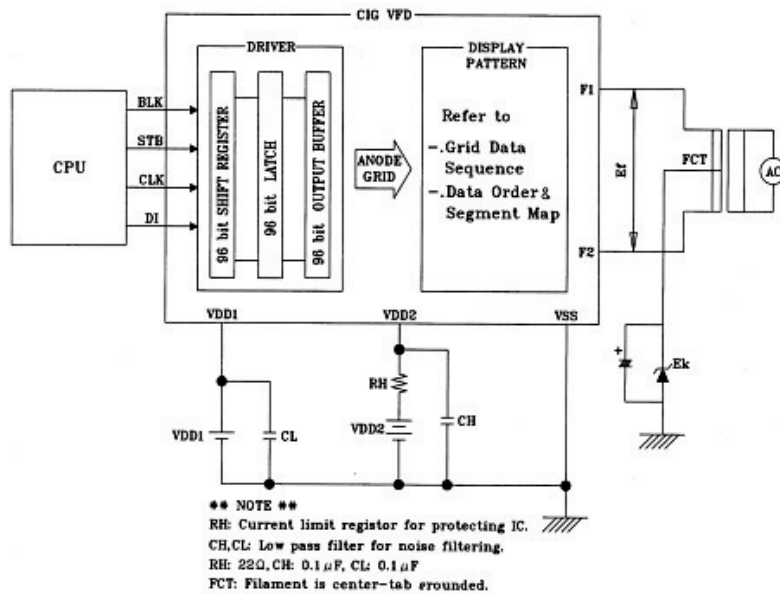

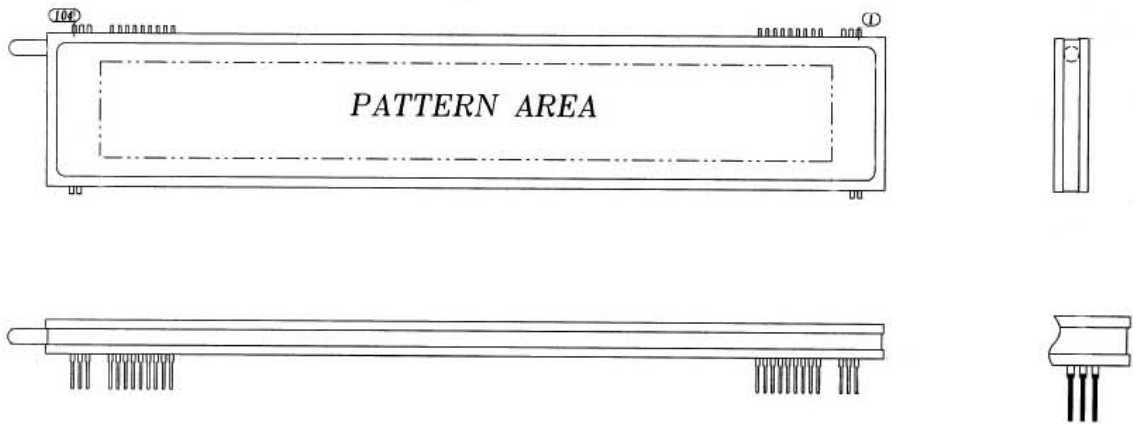

PIN CONNECTION

PIN NO.	104	103	102	101	100	99	98	97	96	95	94	93	92	91	90~15	14~8	5	4	3	2	1
CONNECTION	F2	F2	F2	NP	NP	VDD2	VSS	VSS	CLK	DO	DI	BLK	STB	VDD1	NP	NC	NP	NP	F1	F1	F1

***Notes**

- Fn : Filament Pin
- NP : No Pin
- NC : No Connection Pin
- * DO(Serial data output) : Be left open if not used.

MODEL : HCA-18LL03
 OUTER DIMENSIONS
 Rev. ① 18-Feb-2003

3.PROCESSOR APRT
 IC6.IC10

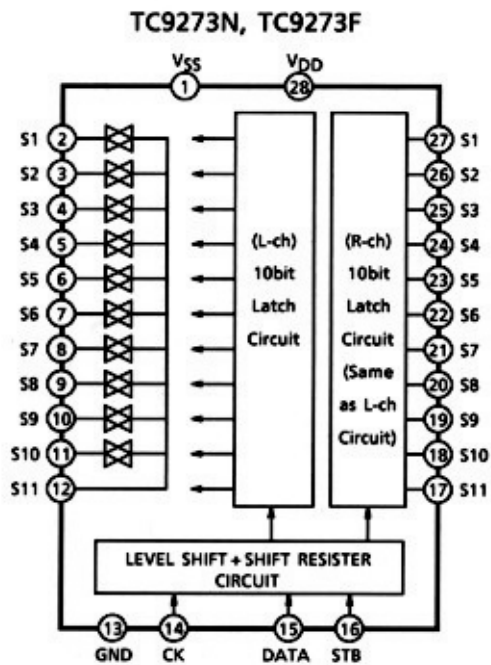

TC9273N, TC9273F

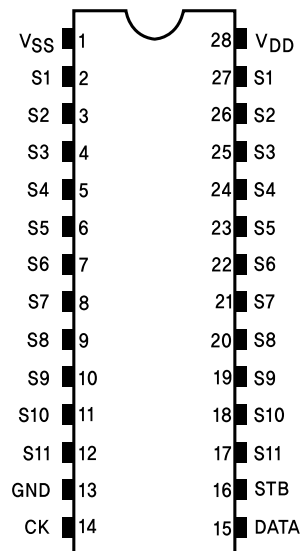

29.NJM2068M
 DSP PART
 PROCESSOR PART

IC100-IC111.IC116.IC117.IC400.IC401.IC402.IC403.IC404
 IC1.IC4.IC7.IC8.IC9.IC11.IC12.IC13.IC15.IC16.IC17.IC20
 IC21.IC23.IC24.IC25.IC26.IC27
 IC22
 IC901-904

MAIN PART
 VIDEO PART

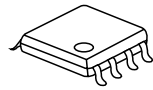

NJM2068M

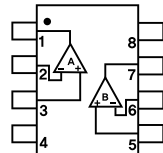

NJM2068D
 NJM2068M
 NJM2068V

30.KIA78R08API
 DSP PART IC601

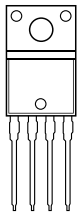

1.Vin 2.VO 3.GND 4.Vdis

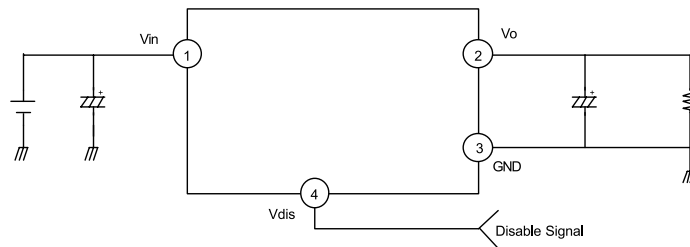

31.RPM6938-RSIP-A3
 FRONT PART RM100

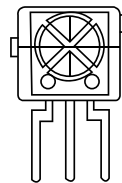
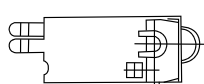

PIN NO.	
①	ROUT
②	GND
③	Vcc

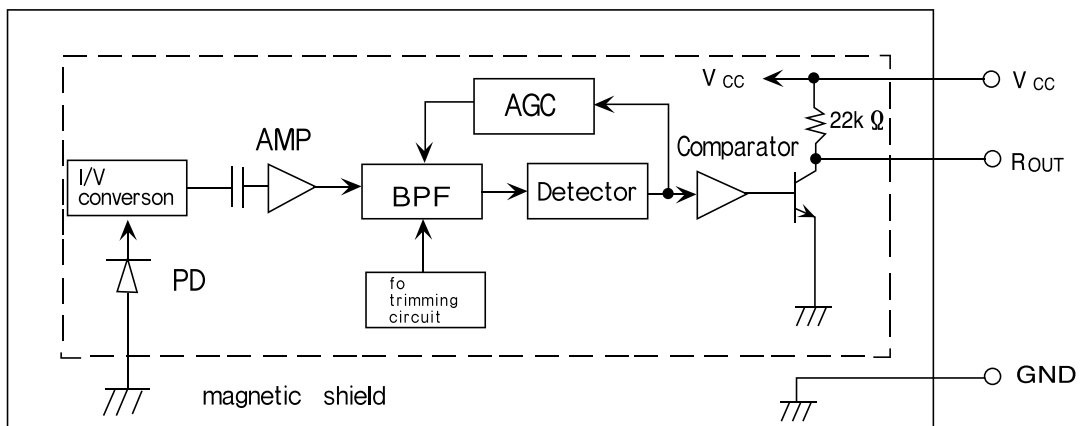

32.BU4053BF
VIDEO PART IC16

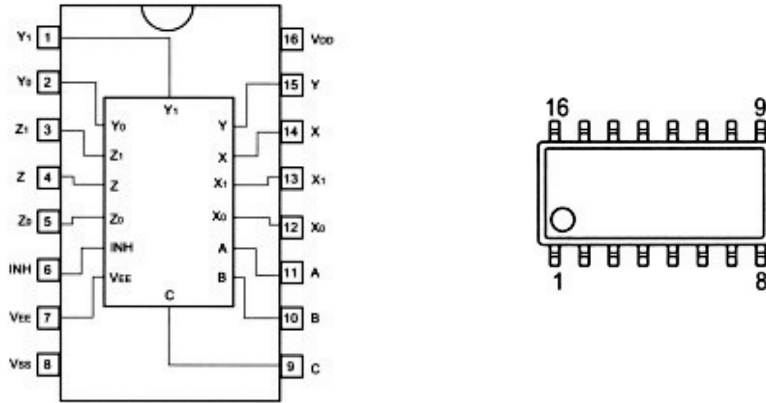

33.CS5361
DSP PART IC112.IC113.IC114.IC115

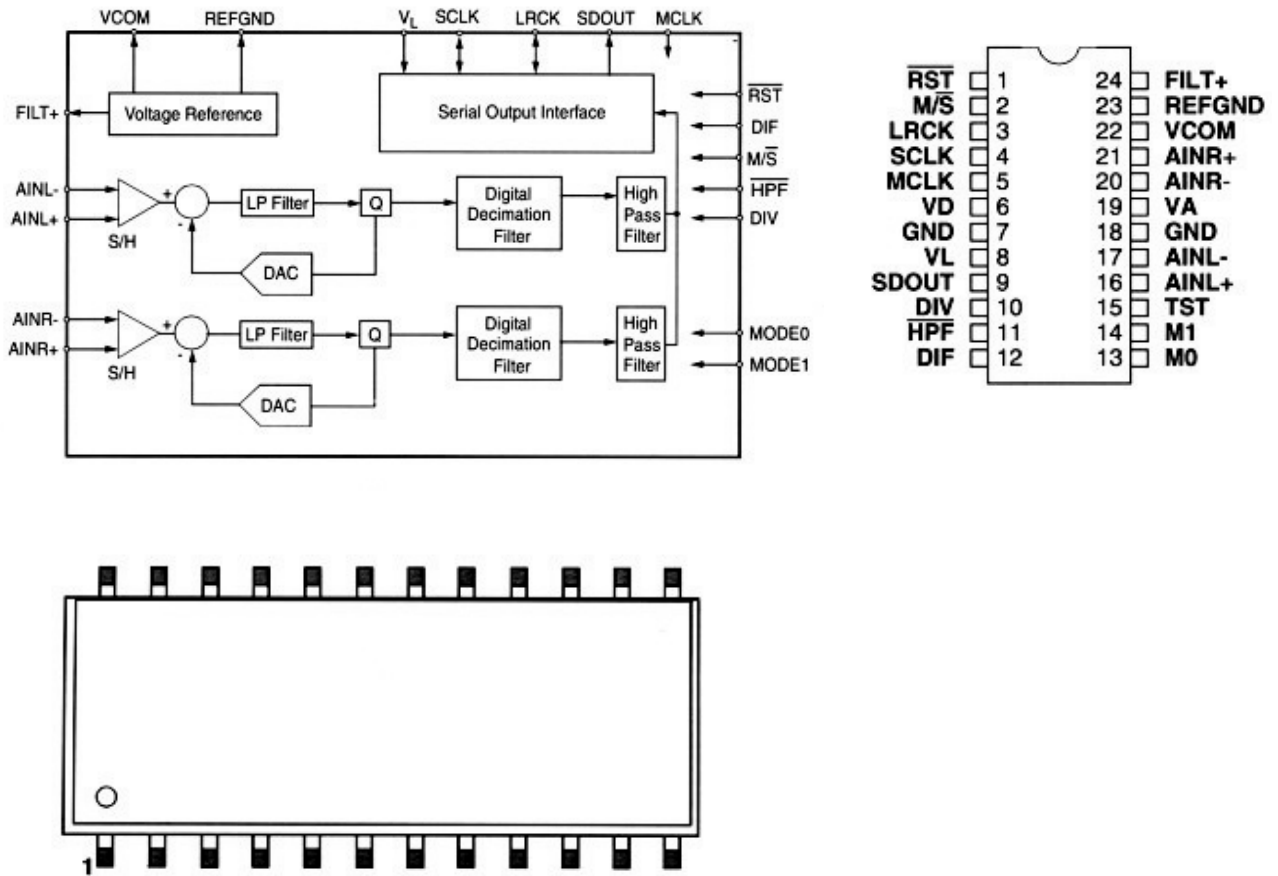

CS49400
DSP PART

IC800

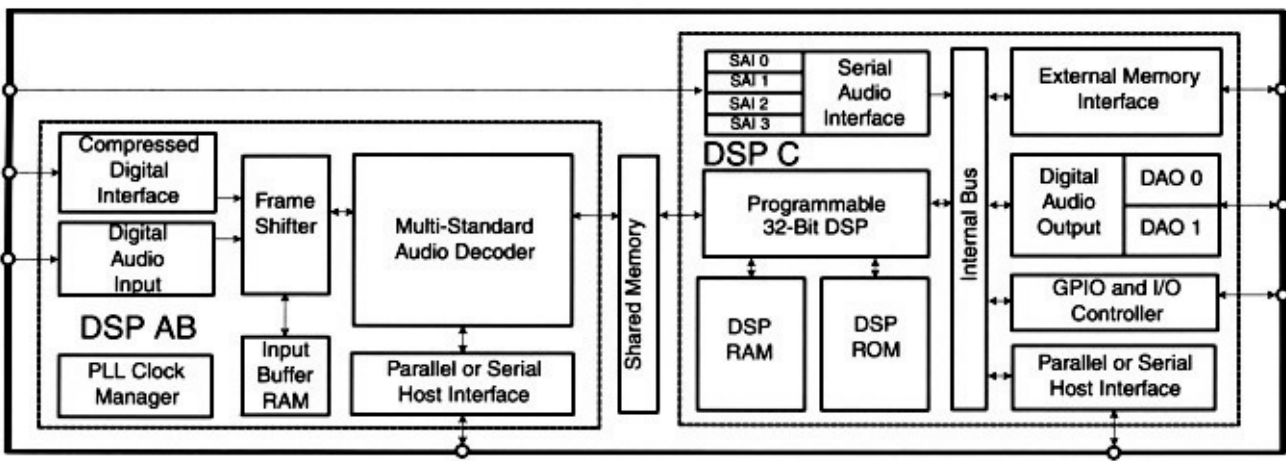
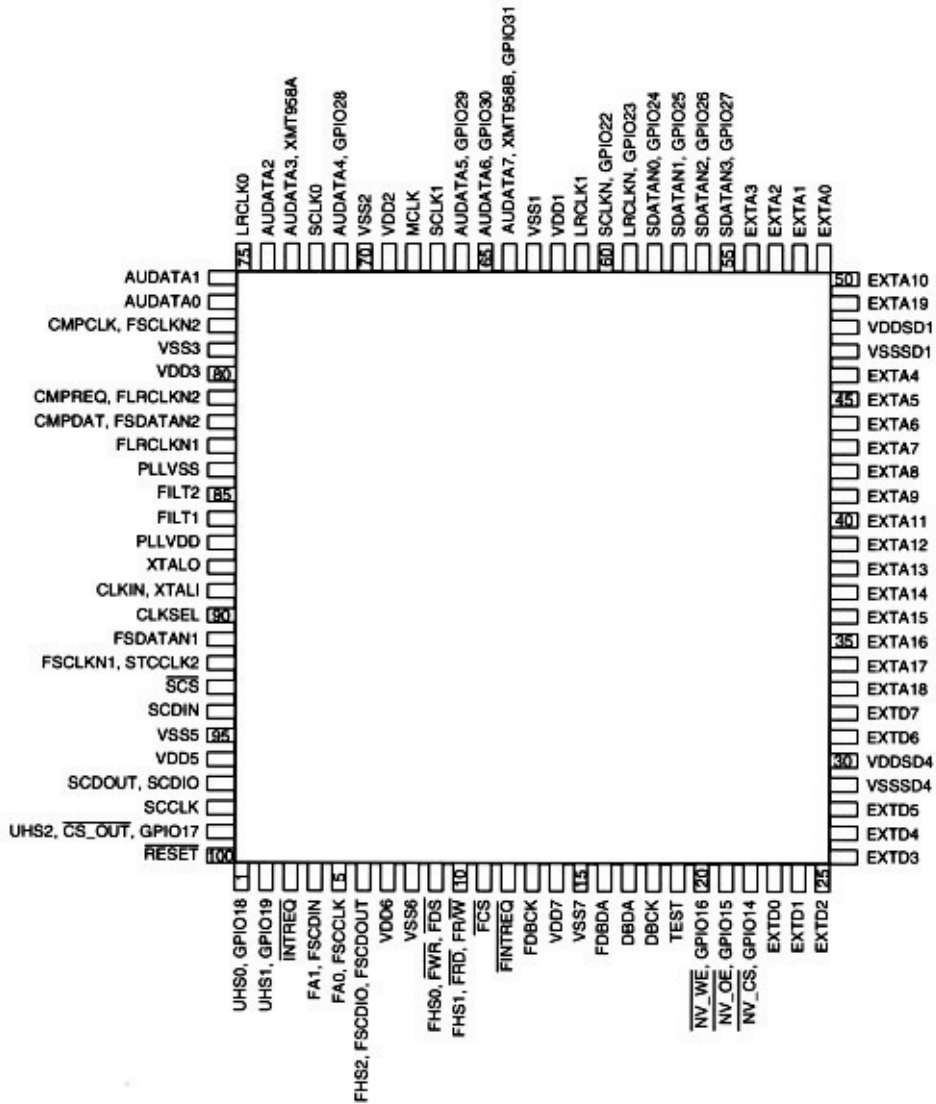

TRANSISTOR BLOCK

- 1.KRC107M
- MAIN PART Q443
- VIDEO PART Q400.501.502
- DTC114YS
- VIDEO PART Q107.110

EQUIVALENT CIRCUIT

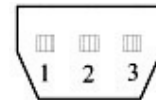
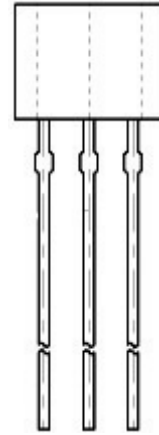
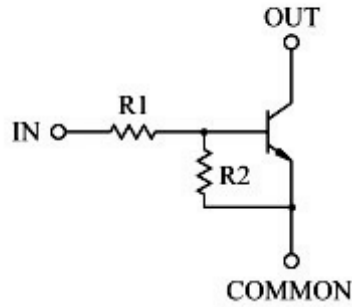

- 1. EMITTER
- 2. COLLECTOR
- 3. BASE

- 2.2SA1145Y
- MAIN PART Q309.310.411.412
- SURROUND PART Q305.405.505

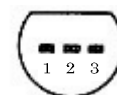
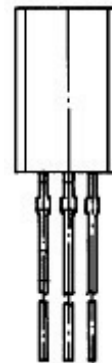
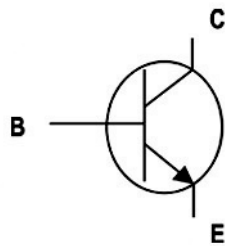

- 1. EMITTER
- 2. COLLECTOR
- 3. BASE

13.KIA7915
 MAIN PART IC52
 KIA7905
 MAIN PART IC56

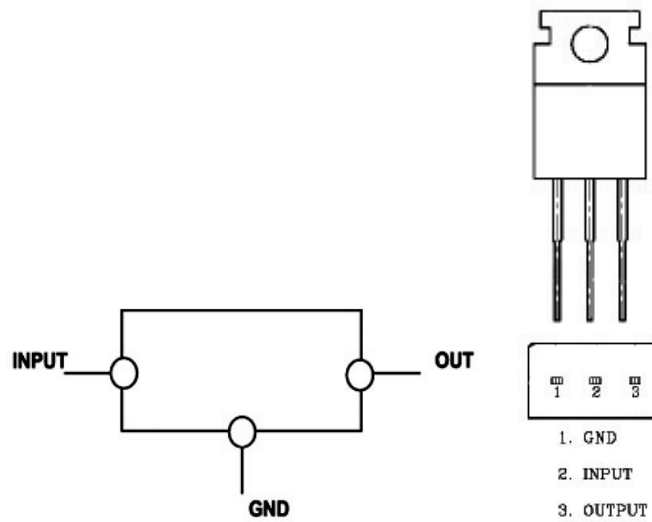

14.DTC114Y
 DSP PART Q600.601.604.605.606.607.608.609.612.613.700
 FRONT PART Q102.103.801.802.803.804.805
 PROCESSOR PART Q54
 VIDEO PART Q105.106.113

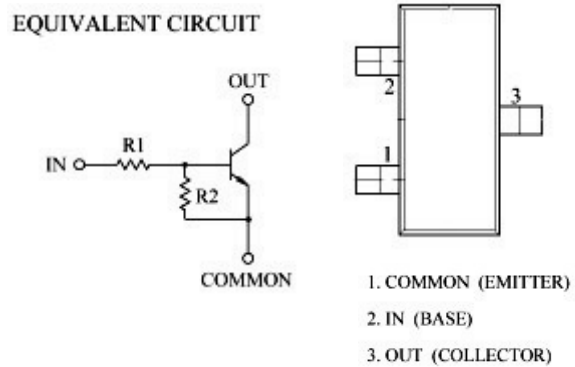

15.DTA114Y
 DSP PART Q402.403
 PROCESSOR PART Q20.3.13.14.17.23.25.32.34.35.37.41.43.50.52
 VIDEO PART Q102.103

EQUIVALENT CIRCUIT

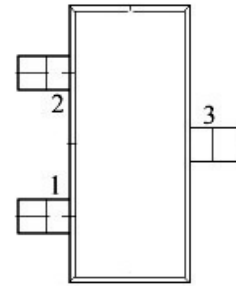
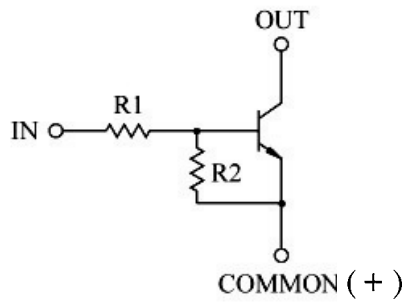

- 1. COMMON (EMITTER)
- 2. IN (BASE)
- 3. OUT (COLLECTOR)

16.KTD1304N
 DSP PART Q400.401
 FRONT PART Q800
 PROCESSOR PART Q4.7.8.9.10.11.12.15.16.51.53.58.59

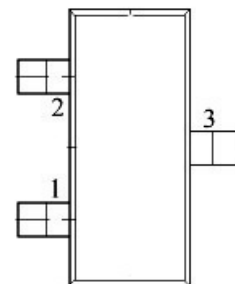
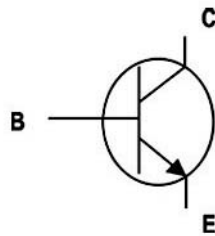

- 1. EMITTER
- 2. BASE
- 3. COLLECTOR

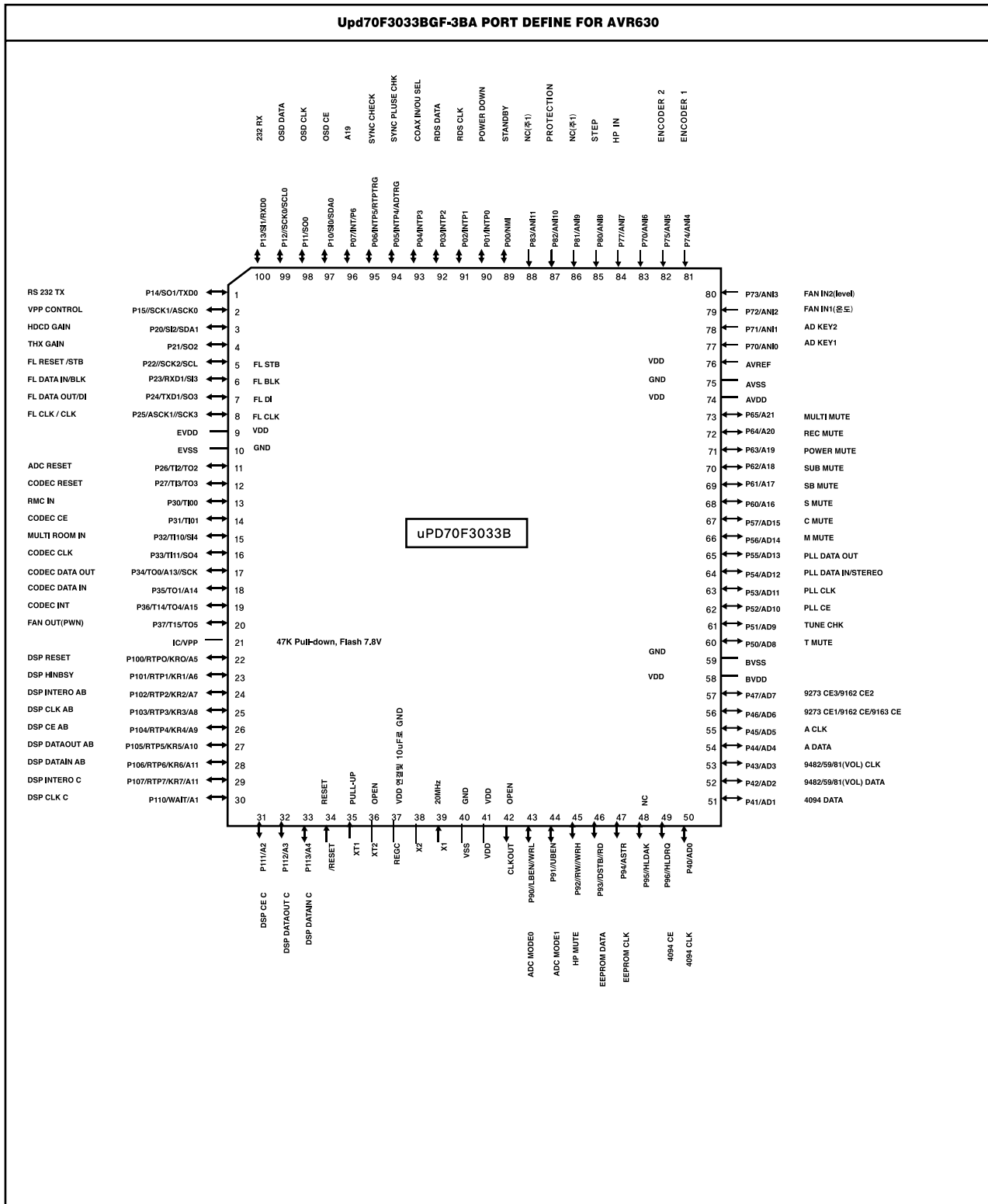

1. Key assignment

- voltage divider method

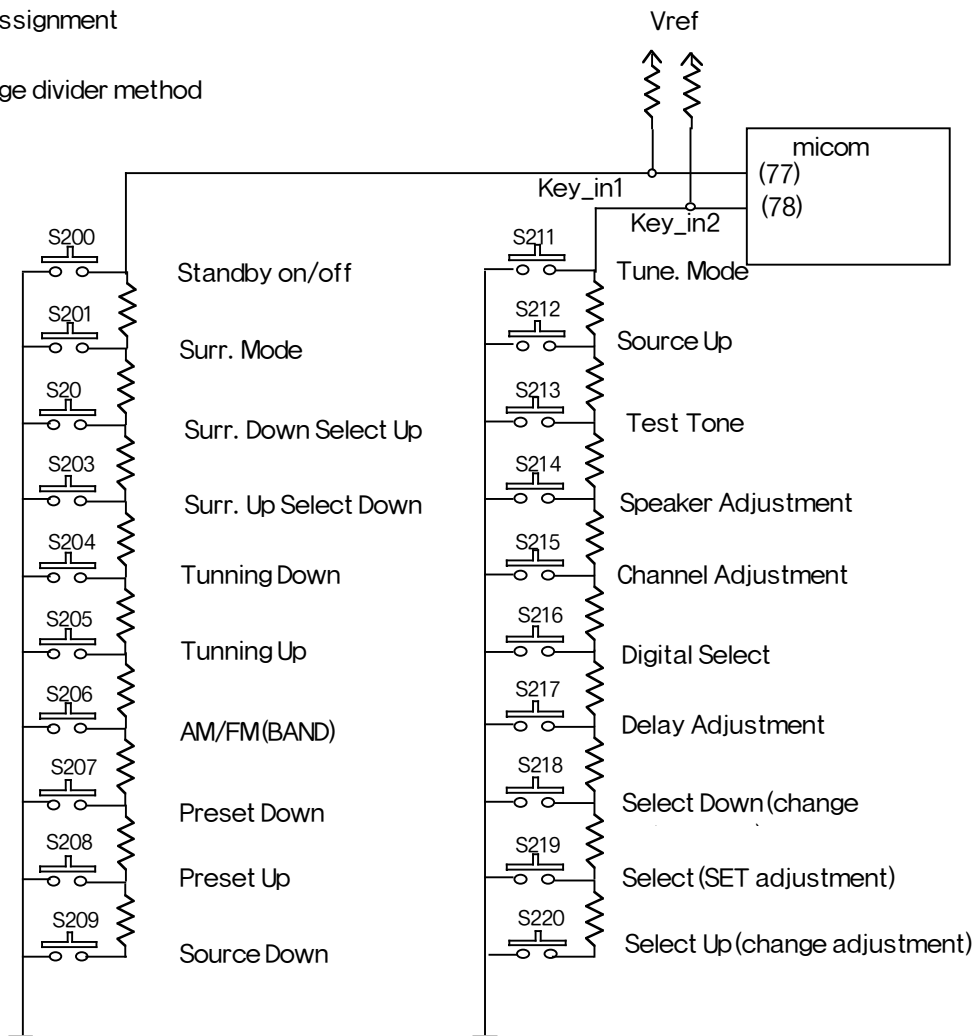

2. Define Option

1) TUNER OPTION:

HIGH(PULL UP - R168(10K)) : RDS
 LOW(PULL DPWN - R654(10K)) : NO RDS

2) NTSC/PAL:

STANDBY OFF--> SELECT UP(FOR 2 SEC) --> SELECT NTSC/PAL BY TOGGLE SELECT UP KEY

----> SET NTSC OR PAL BY SET KEY

OUTLET BOARD (TOP VIEW)

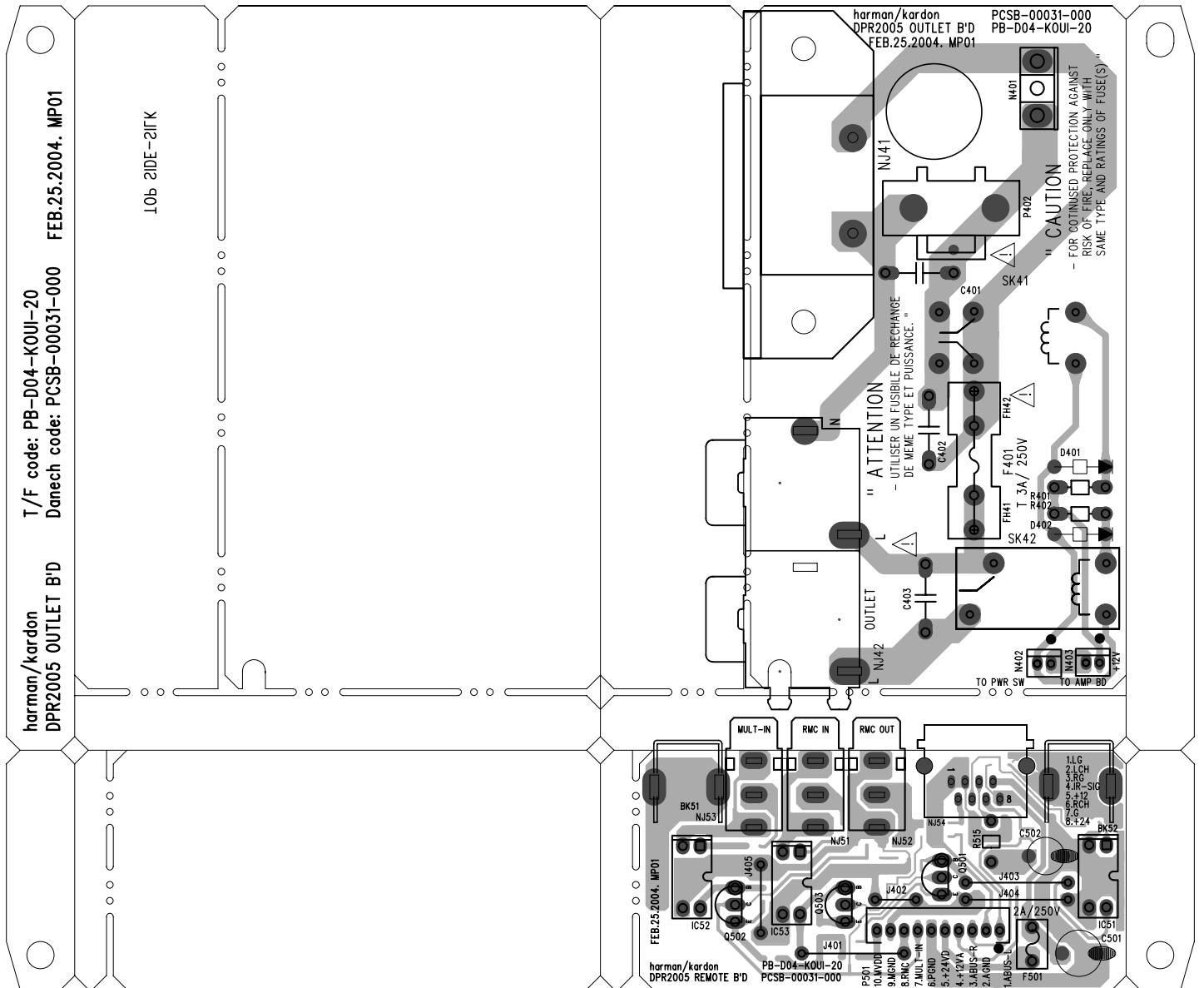

OUTLET BOARD (BOTTOM VIEW)

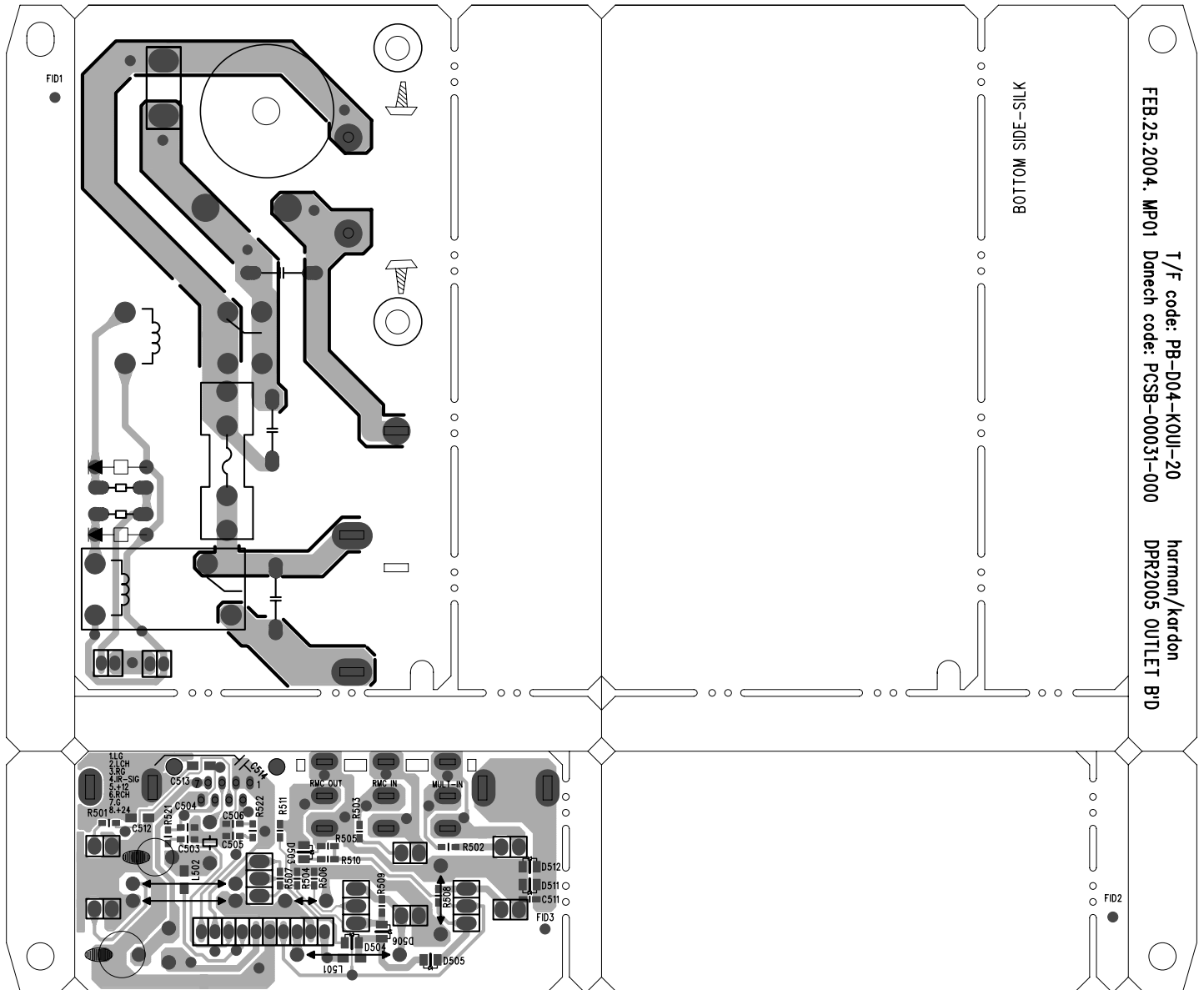

VI DEO BOARD (TOP VI EV)

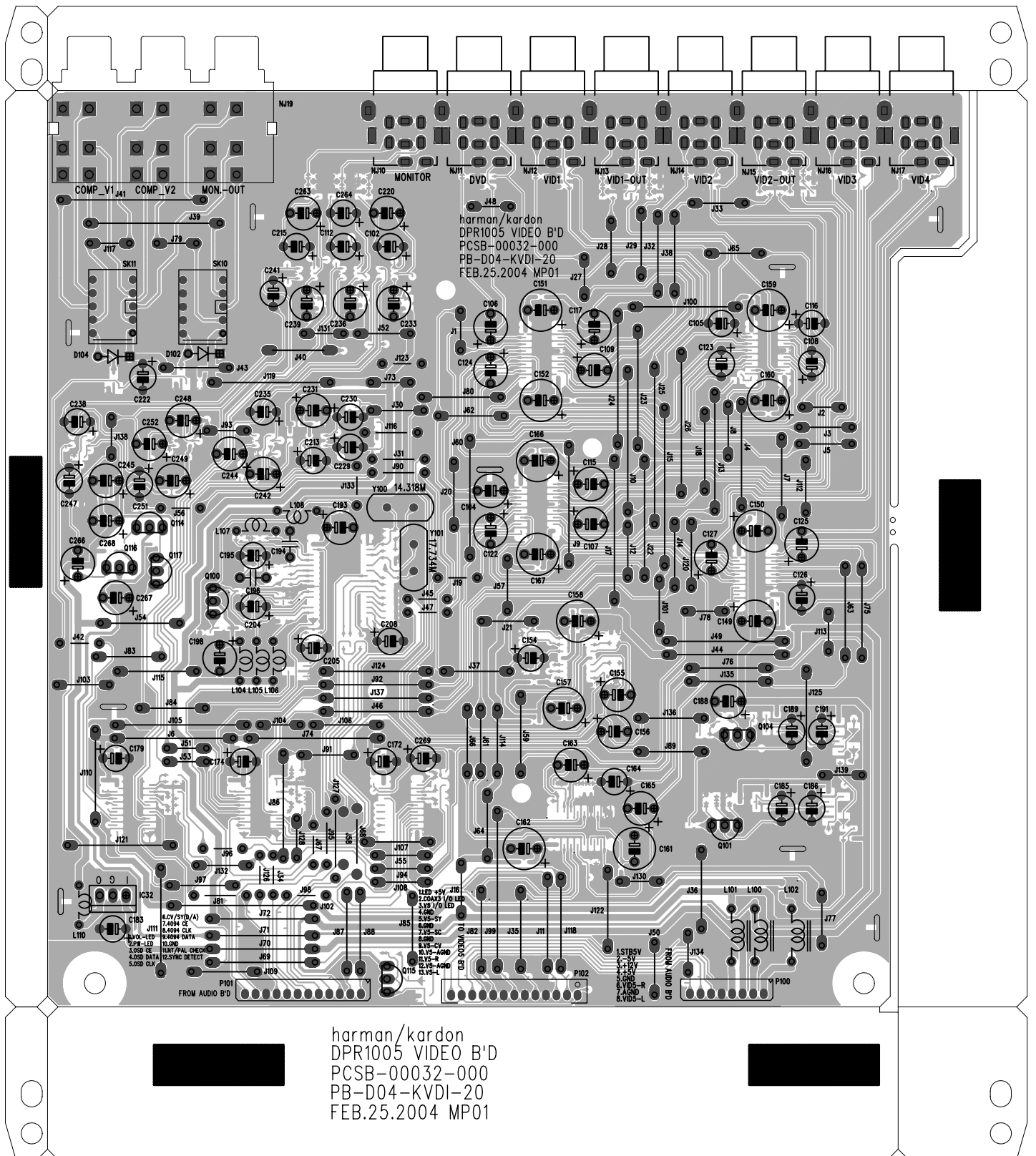

VI DEO BOARD (BOTTOM VI EV)

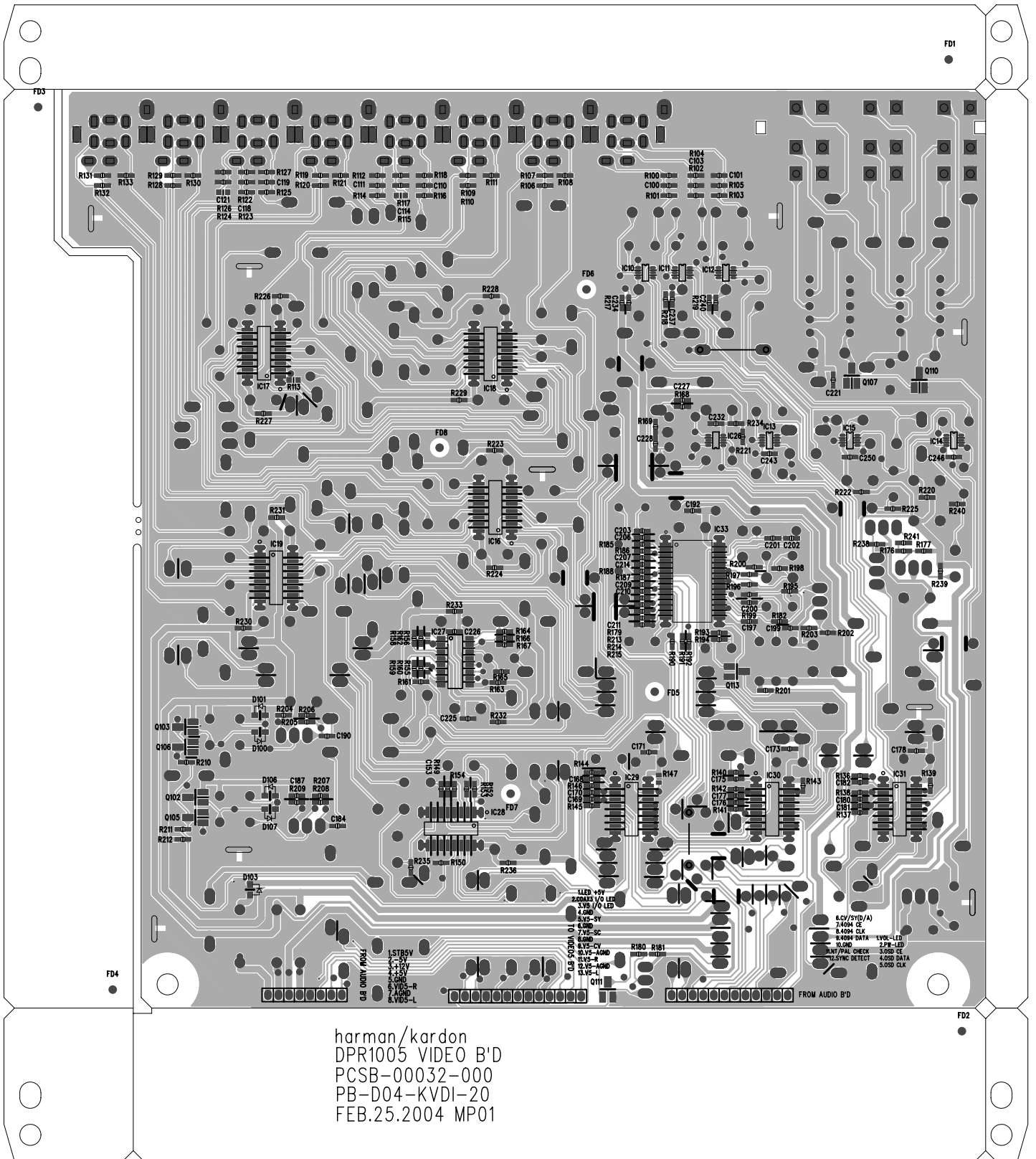

PROCESSOR BOARD (TOP VIEW)

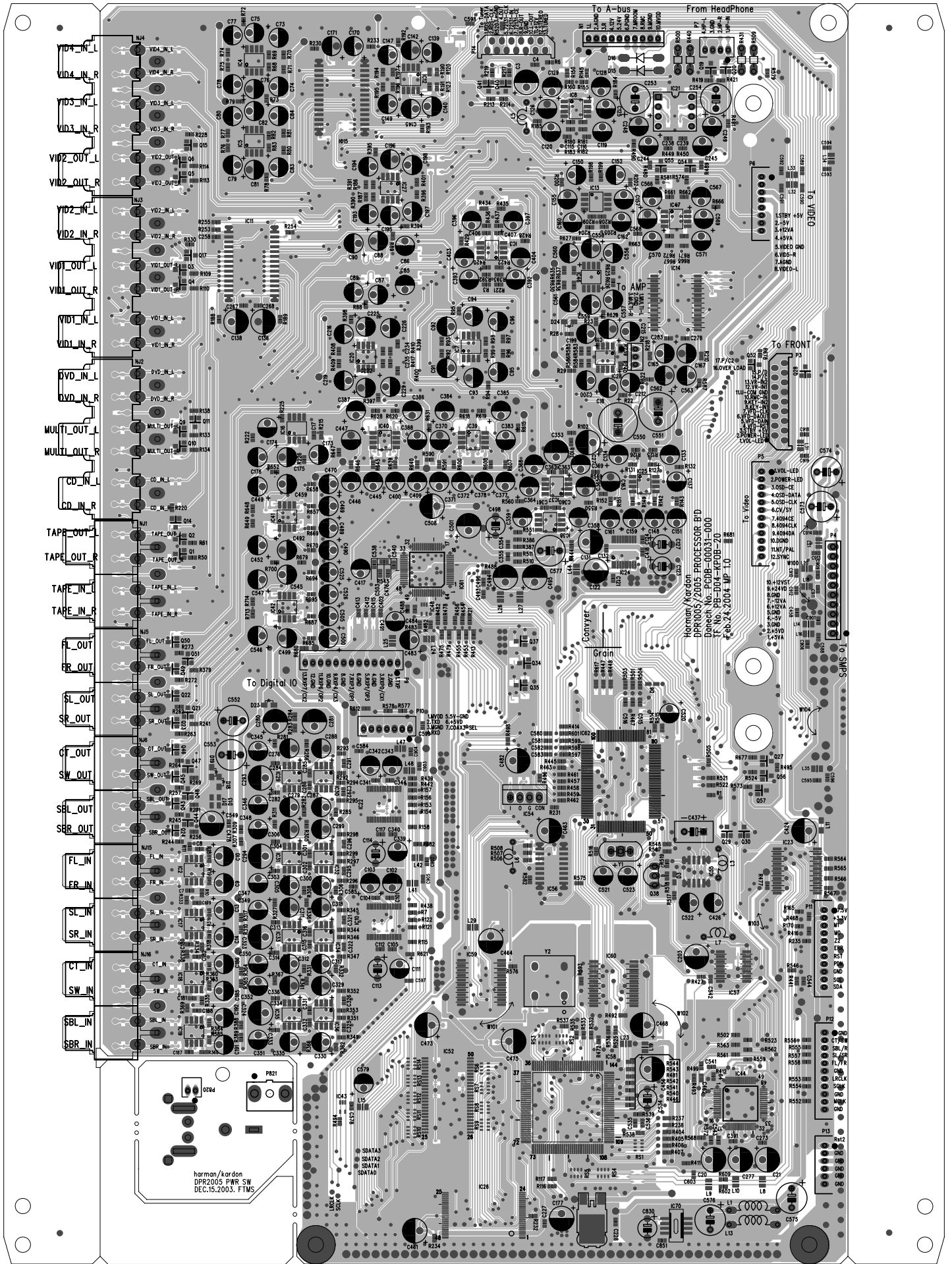

PROCESSOR BOARD (BOTTOM VIEW)

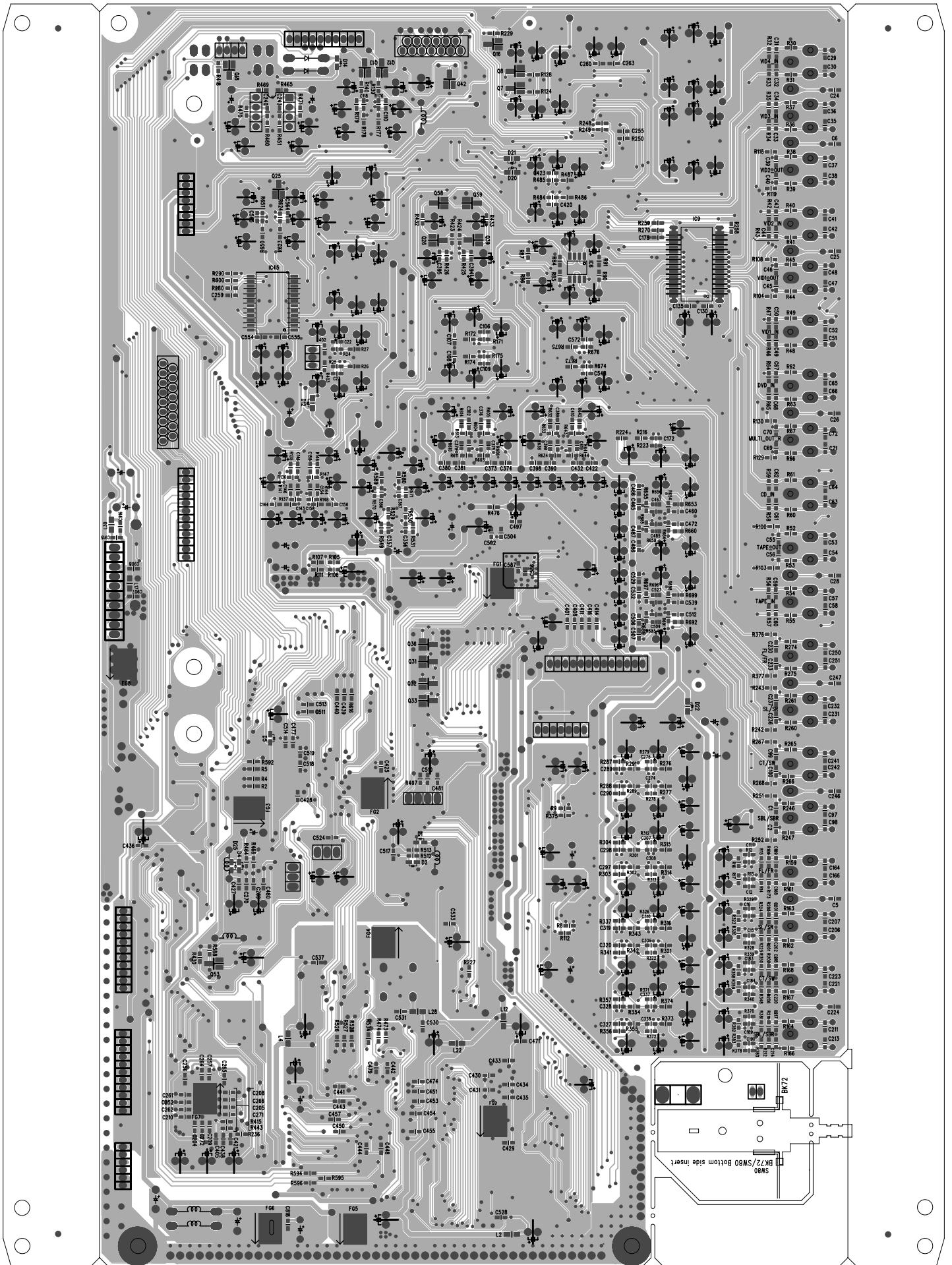

FRONT BOARD (TOP VIEW)

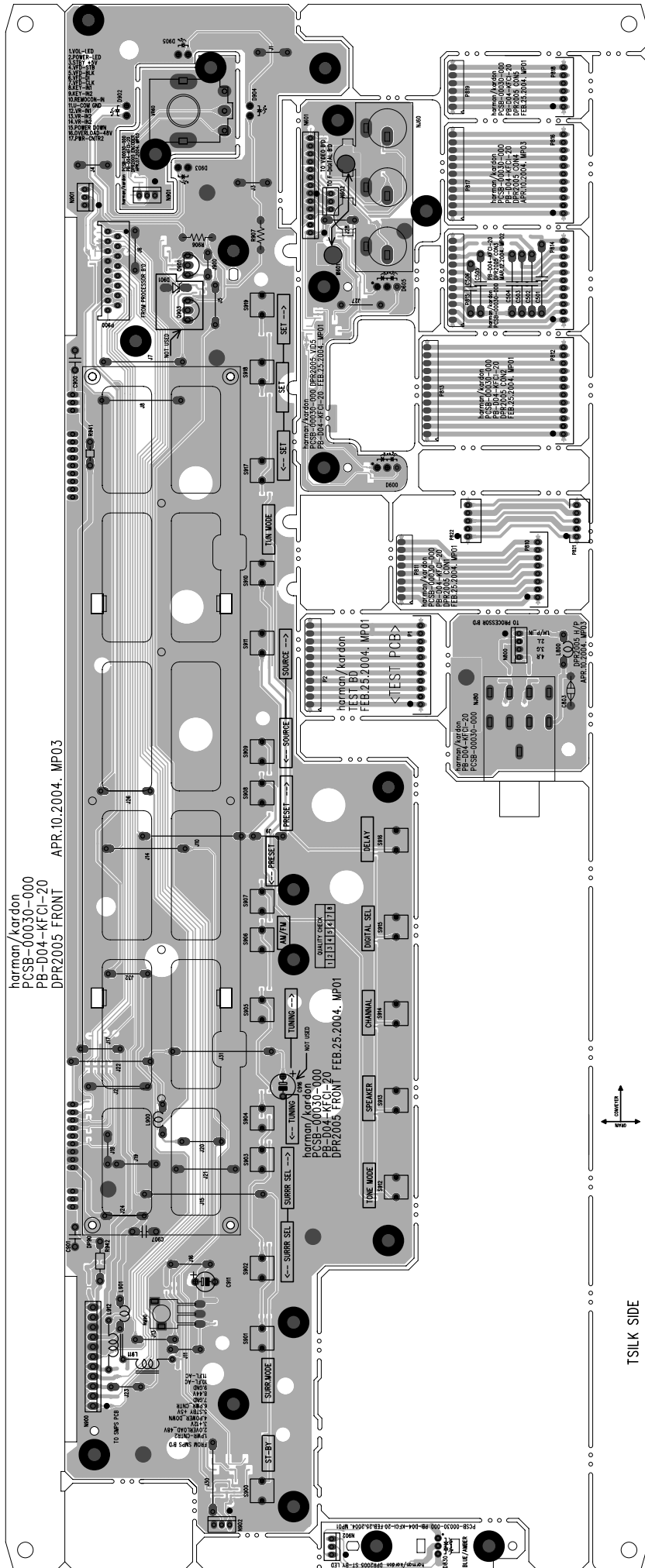

FRONT BOARD (BOTTOM VIEW)

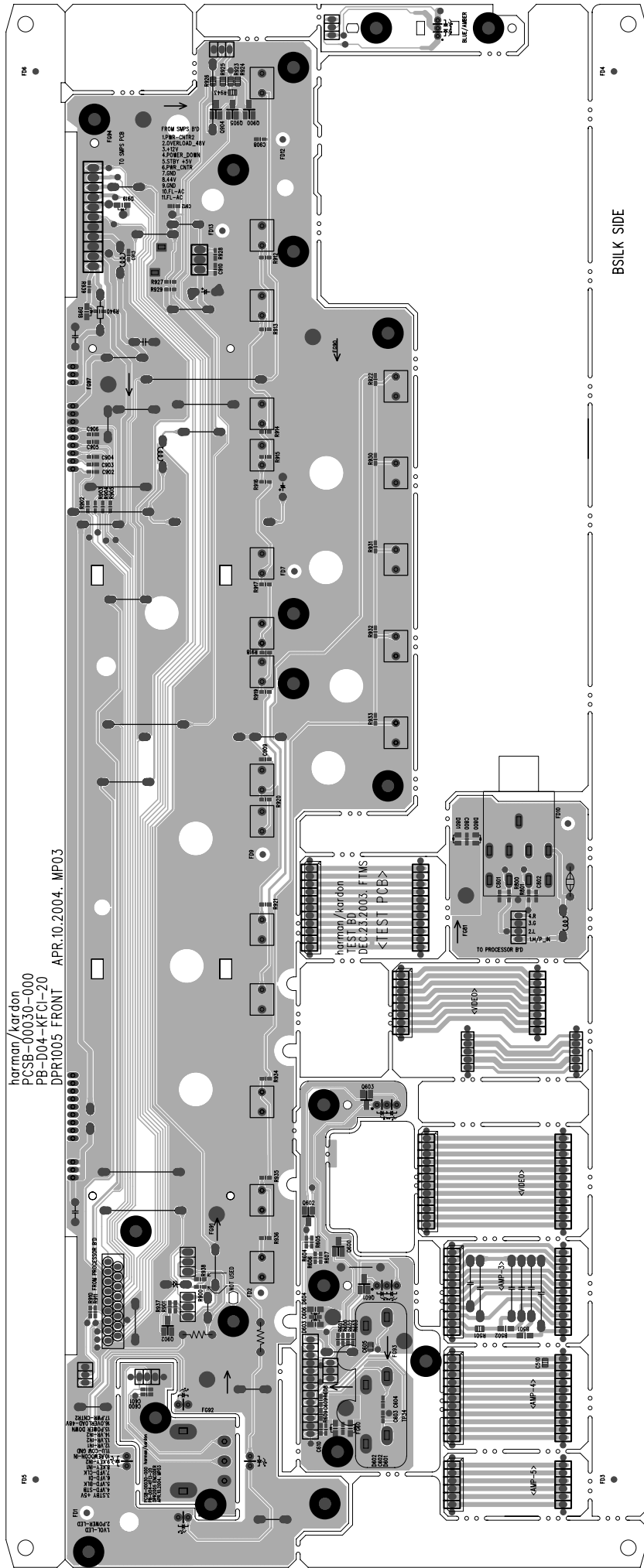

harman/kardon
 PCSB-00030-000
 PB-D04-KFCI-20
 DPR1005 FRONT APR.10.2004, MP03

harman/kardon
 TEST ED
 DEC.23.2003, FTMS
 <TEST PCB>

AMP BOARD (TOP VIEW)

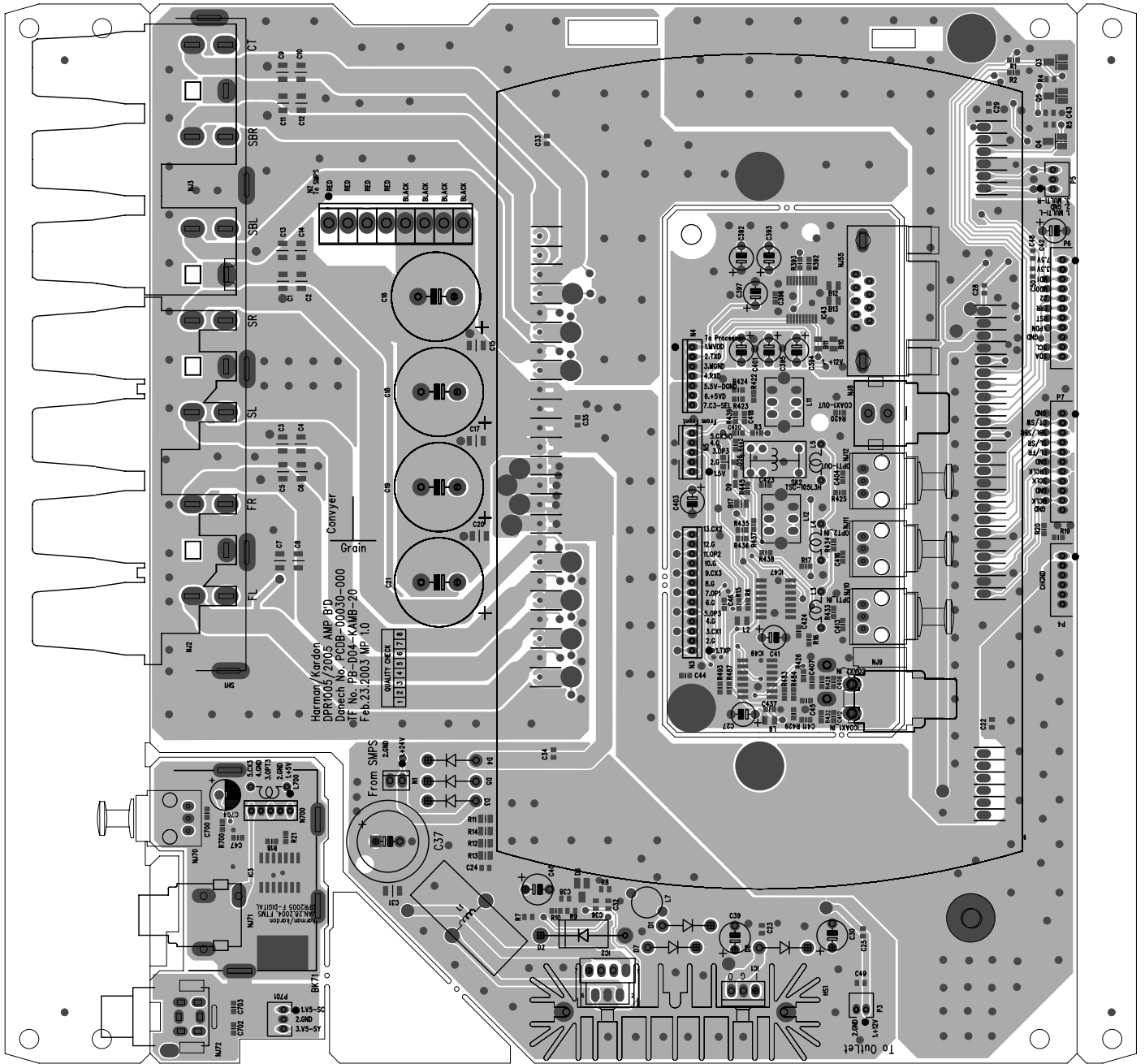

AMP BOARD (BOTTOM VIEW)

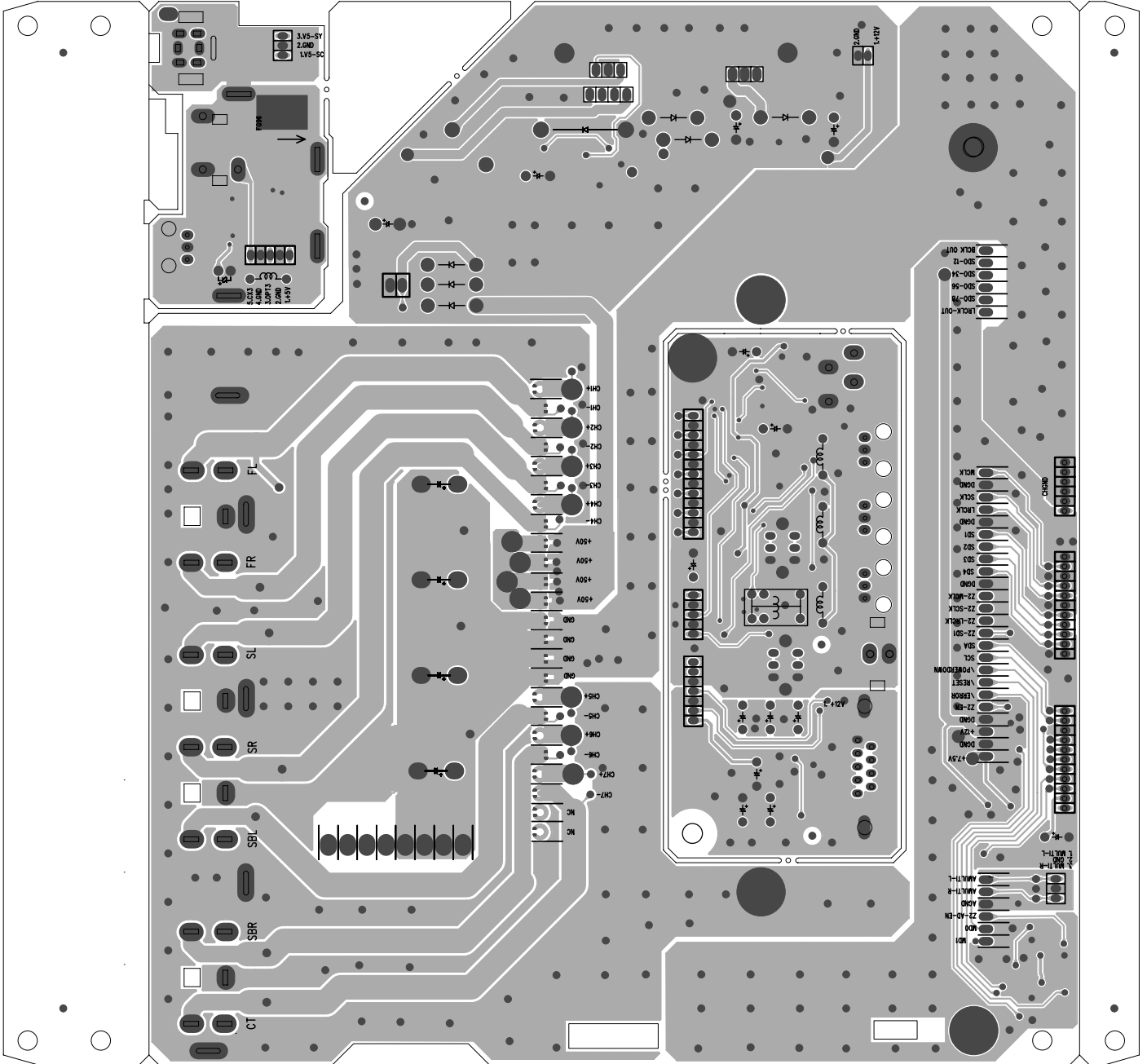

NOTE: Ordinarily the DPR1005/2005 SMPS Power Supply module is supplied only as a complete unit. Supplied Schematic and Parts list are included only for reference when the above part is not available and/or repair to component level is necessary.

For h/k part number equivalents, contact harman/kardon at 516-255-4545 ext. 6553

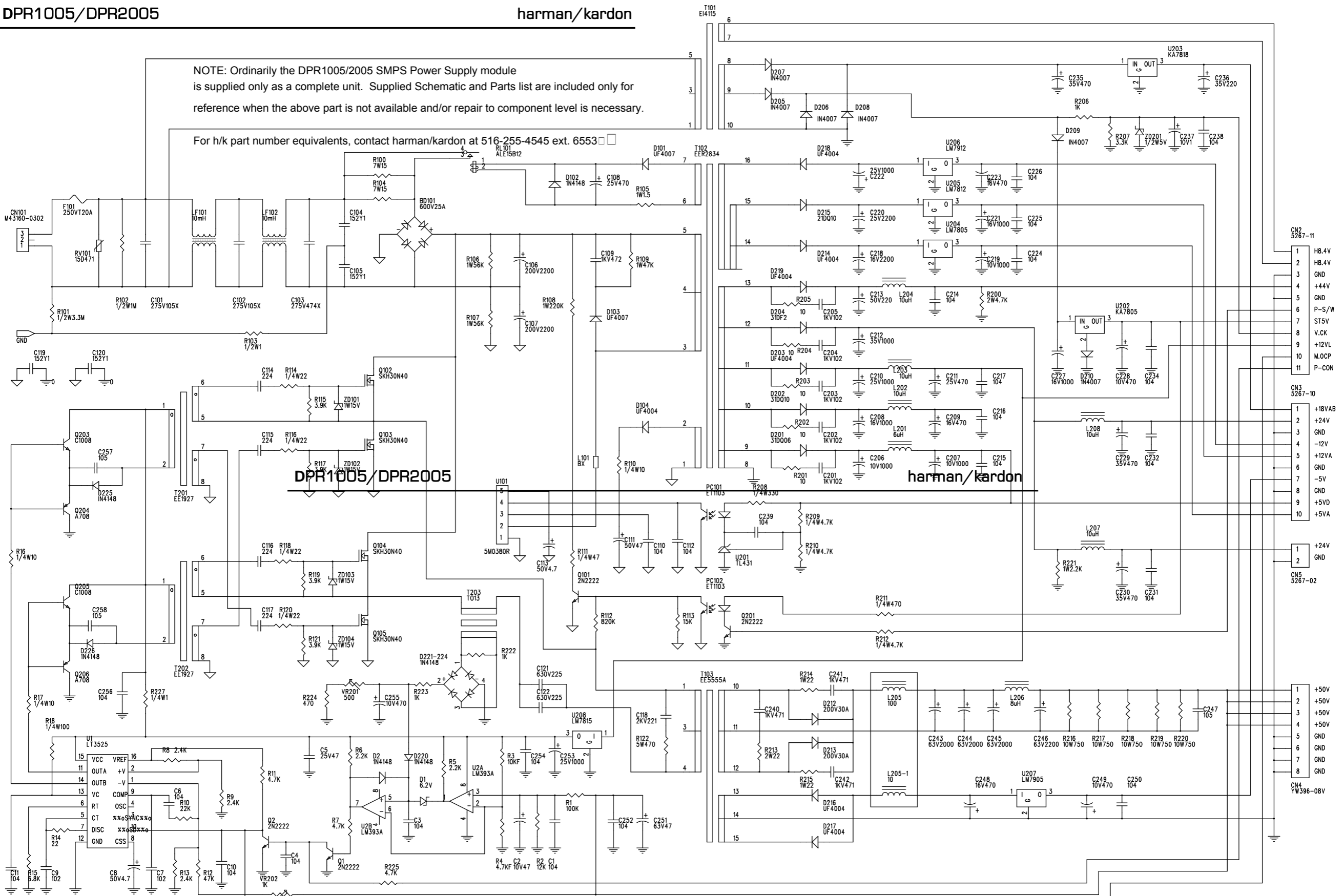

DPR1005/DPR2005

harman/kardon

Title	AUDIO POWER	
Size	Document Number	Rev
A2	KJP2001	1
Date:	Tuesday, December 09, 2003 9:00	Sheet 1 of 1

SCHEMATIC DIAGRAM

harman kardon
DPR2005/1005 OUTLET B'D

REVISION RECORD		
NO.	Date	Contents

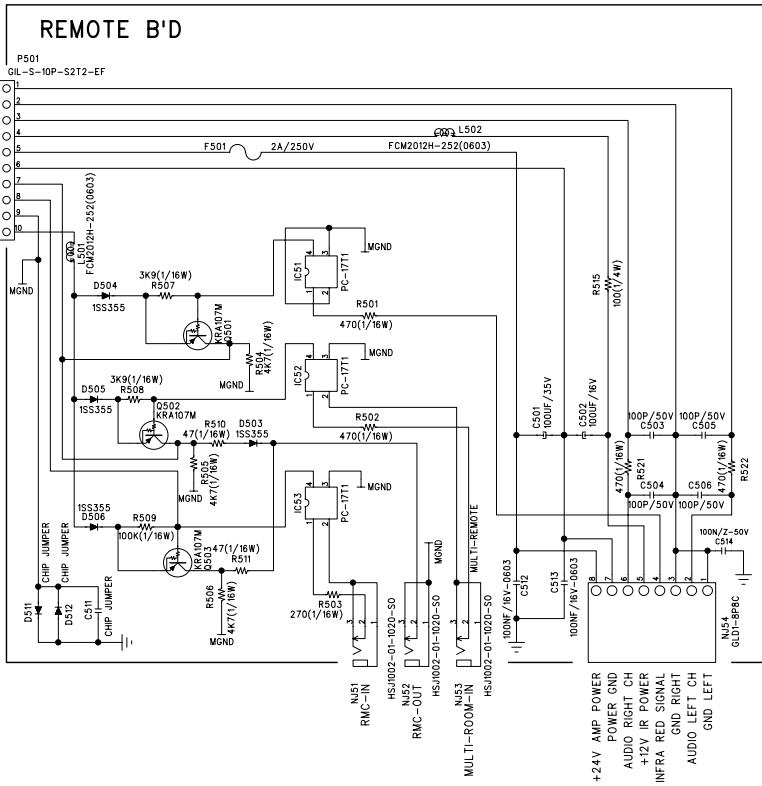
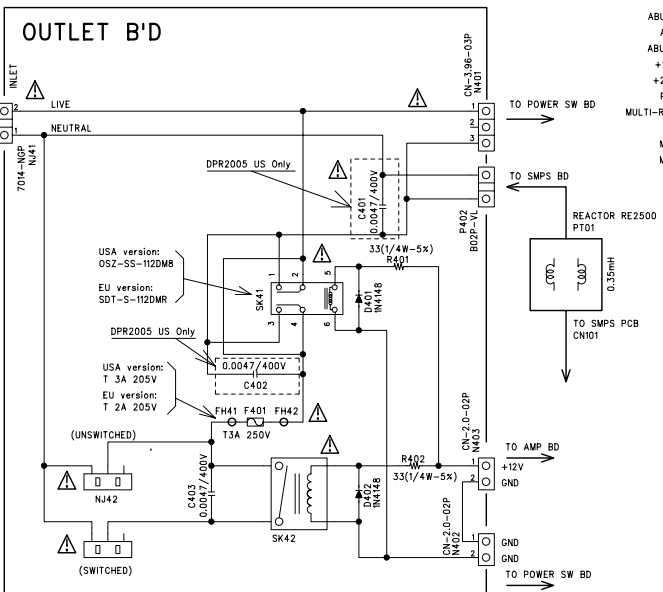

*** IMPORTANT SAFETY NOTICE. COMPONENTS IDENTIFIED BY **MARK** HAVE SPECIAL CHARACTERISTICS IMPORTANT FOR SAFETY. WHEN REPLACING ANY OF THESE COMPONENTS USE ONLY MANUFACTURER'S SPECIFIED PARTS.
 *** THE UNIT OF RESISTANCE IS OHM.
 K=1000 OHM, M=1000 KOHM.
 *** THE UNIT OF CAPACITANCE IS MICROFARAD (uF)
 uF=10⁻⁶ F
 *** THIS SCHEMATIC DIAGRAM MAY MODIFIED AT ANYTIME WITH THE IMPROVEMENT OF PERFORMANCE.

Category	AV RECEIVER	Model	DPR2005/1005
Stage	Ver.	Sheet	B'D name
		4 / 10	OUTLET
Draw	Approved	Date	Drawing No

SCHEMATIC DIAGRAM harman/kardon DPR1005/2005 FRONT B'D

REVISION RECORD		
No.	Date	Contents

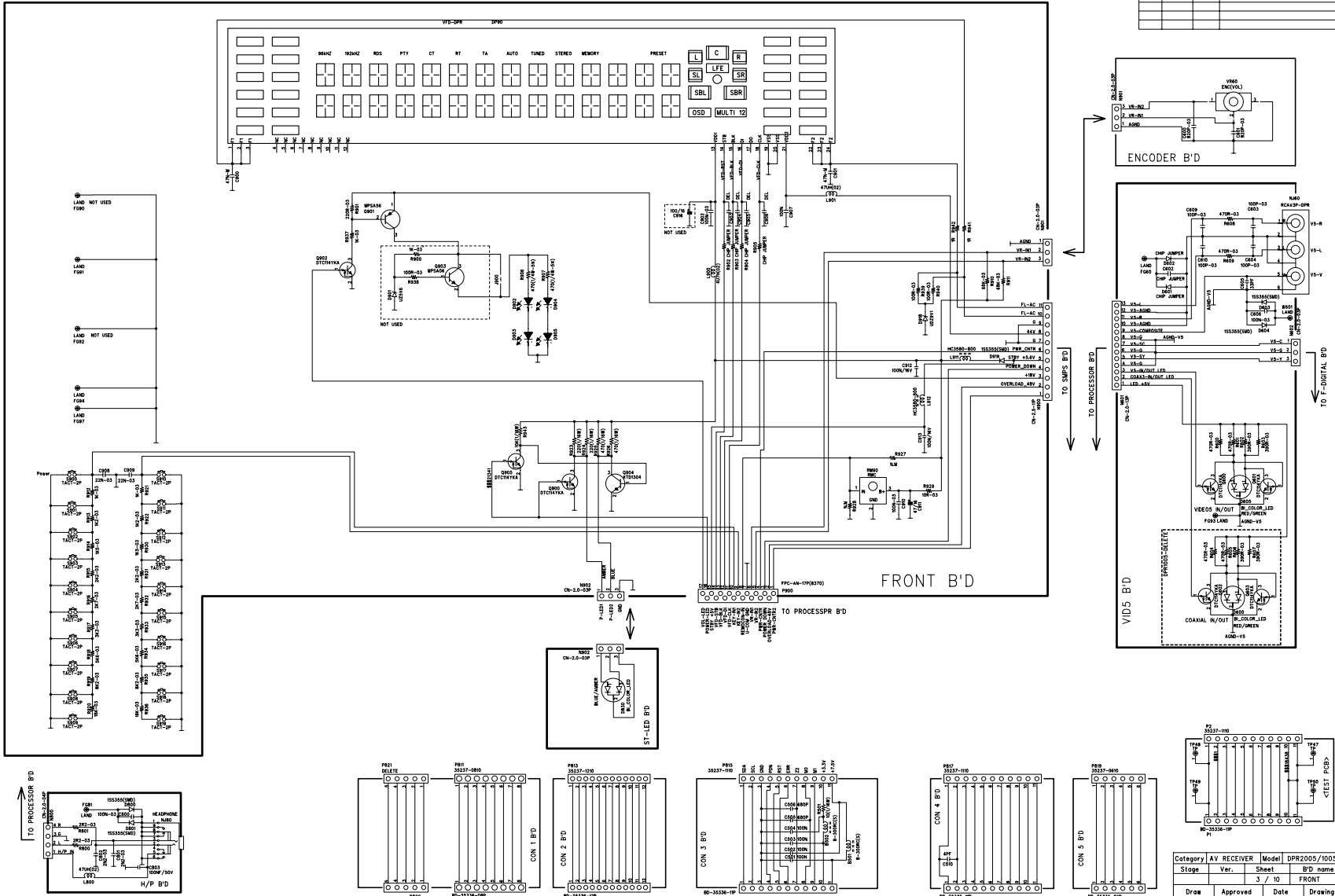

Category	AV RECEIVER	Model	DPR2005/1005
Stage	Ver.	Sheet	B'D Name
Draw	Approved	Date	FRONT
			Drawing No

SCHEMATIC DIAGRAM

harman kardon DPR2005/1005 PROCESSOR B'D (1/5)

REVISION RECORD		
NO.	Date	Contents

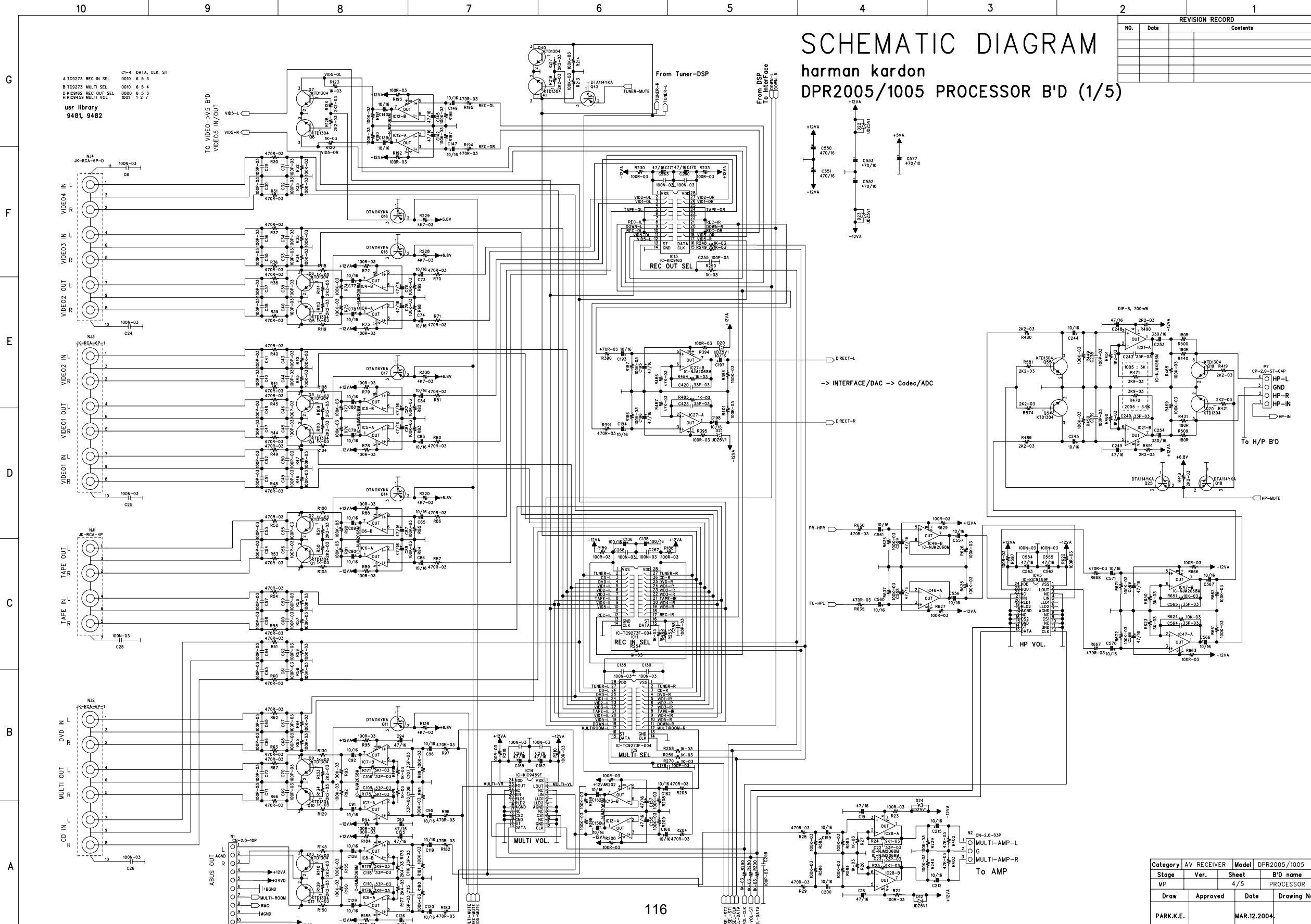

Category	AV RECEIVER	Model	DPR2005/1005
Stage	Ver.	Sheet	B'D name
MP		4/5	PROCESSOR
Draw	Approved	Date	Drawing No
PARK.K.E.		MAR.12.2004	

SCHEMATIC DIAGRAM

harman kardon

DPR2005/1005 PROCESSOR B'D (2/5)

REVISION RECORD		
NO.	Date	Contents

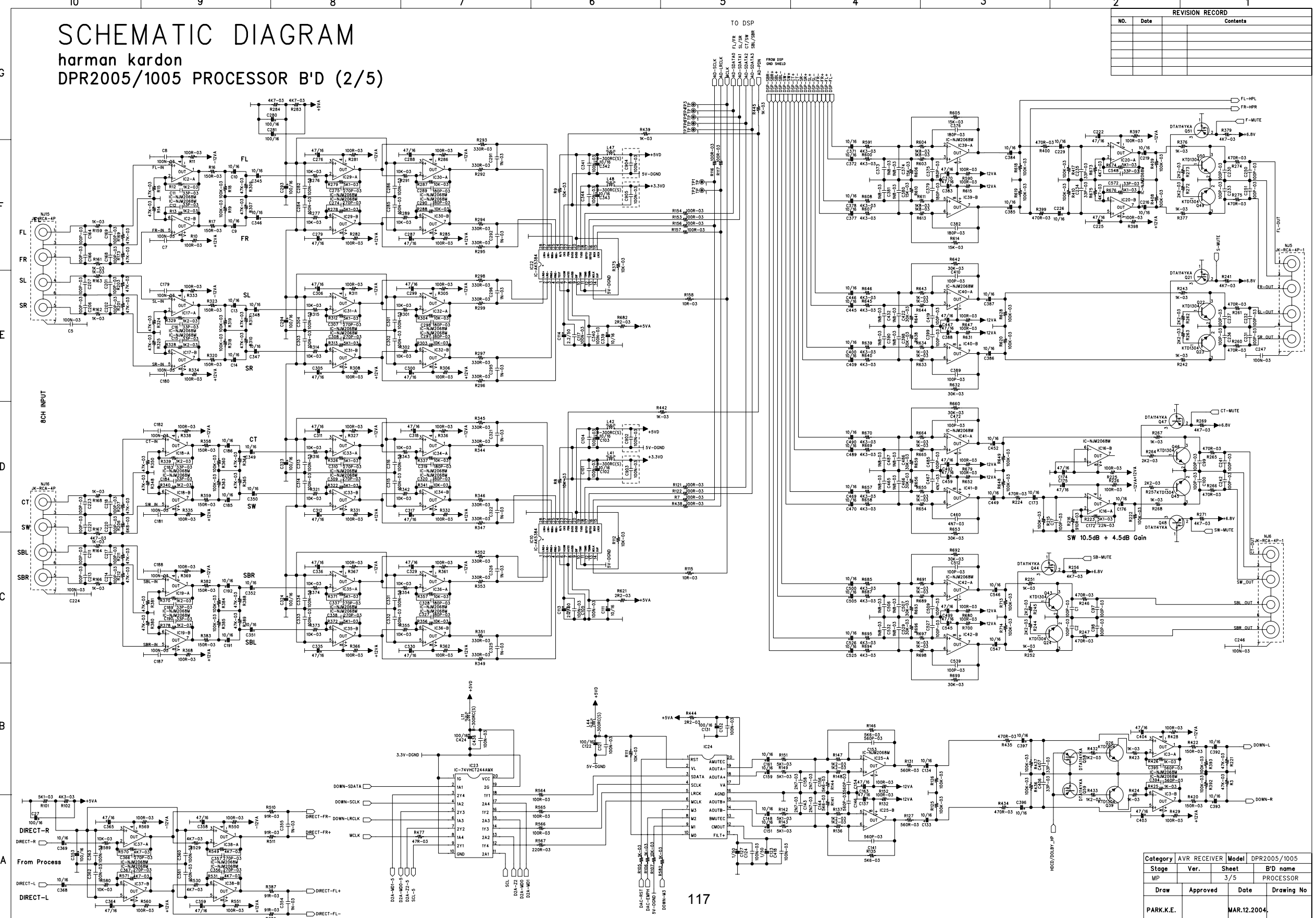

Category	AVR RECEIVER	Model	DPR2005/1005
Stage	Ver.	Sheet	B'D name
MP		3/5	PROCESSOR
Draw	Approved	Date	Drawing No
PARK.K.E.		MAR.12.2004.	

REVISION RECORD		
NO.	Date	Contents

SCHEMATIC DIAGRAM

harman kardon

DPR2005/1005 PROCESSOR B'D (3/5)

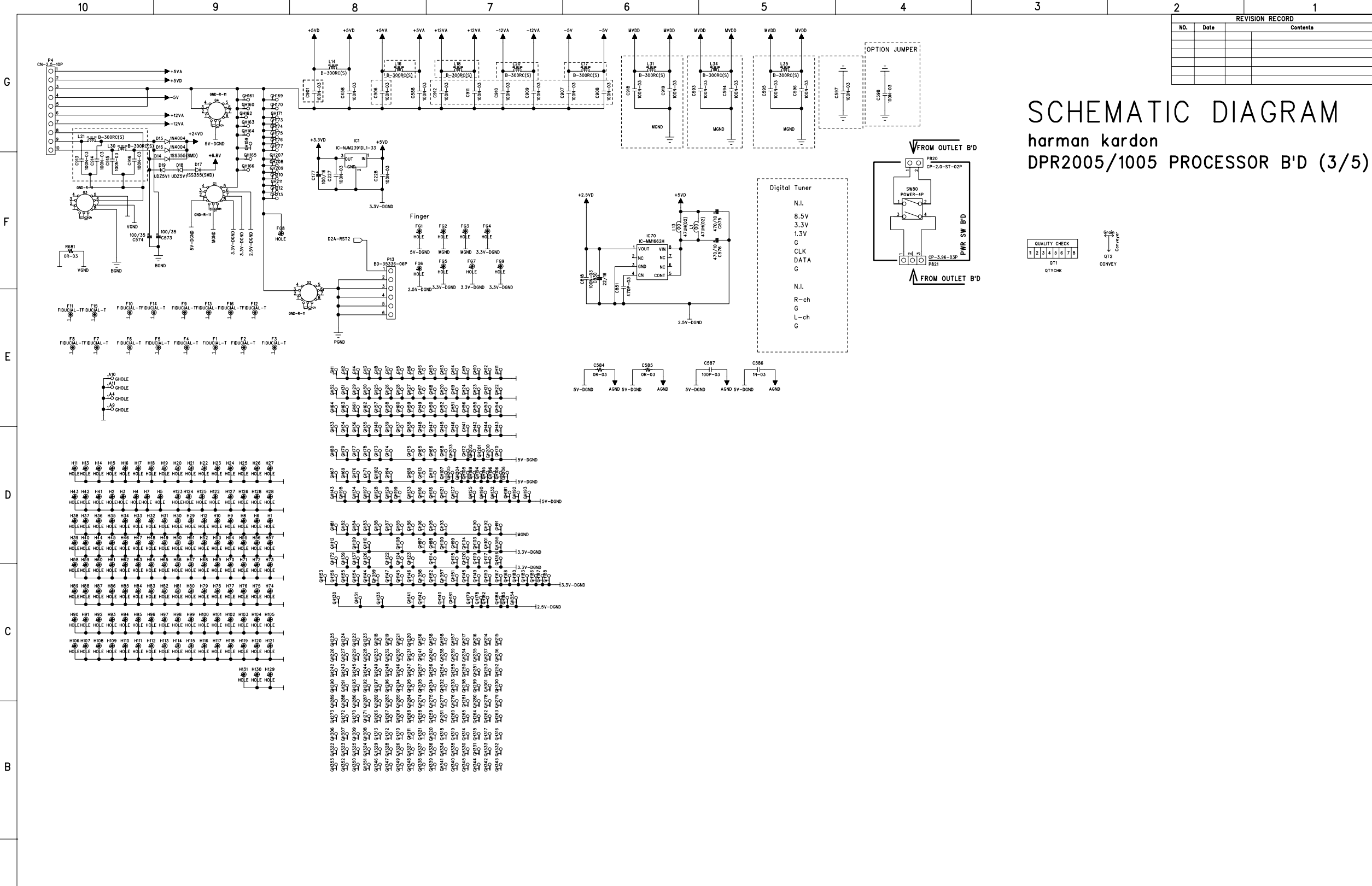

Category	AV RECEIVER	Model	DPR2005/1005
Stage	Ver.	Sheet	B'D name
MP		5/5	PROCESSOR
Draw	Approved	Date	Drawing No
PARK.K.E.		MAR.12.2004.	

SCHEMATIC DIAGRAM

harman kardon

DPR2005/1005 PROCESSOR B'D (4/5)

REVISION RECORD		
No.	Date	Contents

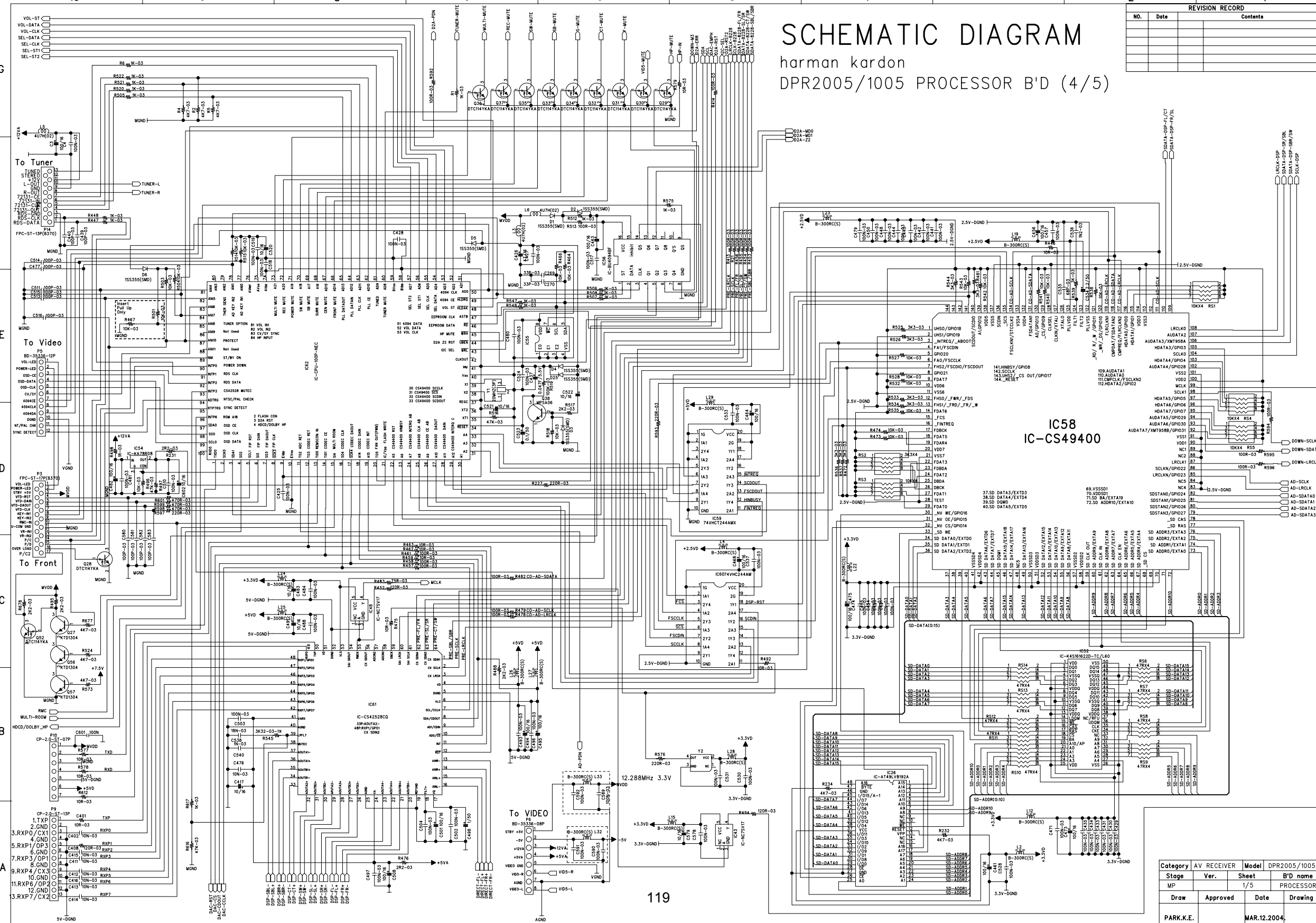

Category	AV RECEIVER	Model	DPR2005/1005
Stage	Ver.	Sheet	B'D name
MP		1/5	PROCESSOR
Draw	Approved	Date	Drawing No
PARK.K.E.		MAR.12.2004.	

SCHEMATIC DIAGRAM

harman kardon
DPR2005/1005 PROCESSOR B'D (5/5)

REVISION RECORD		
No.	Date	Contents

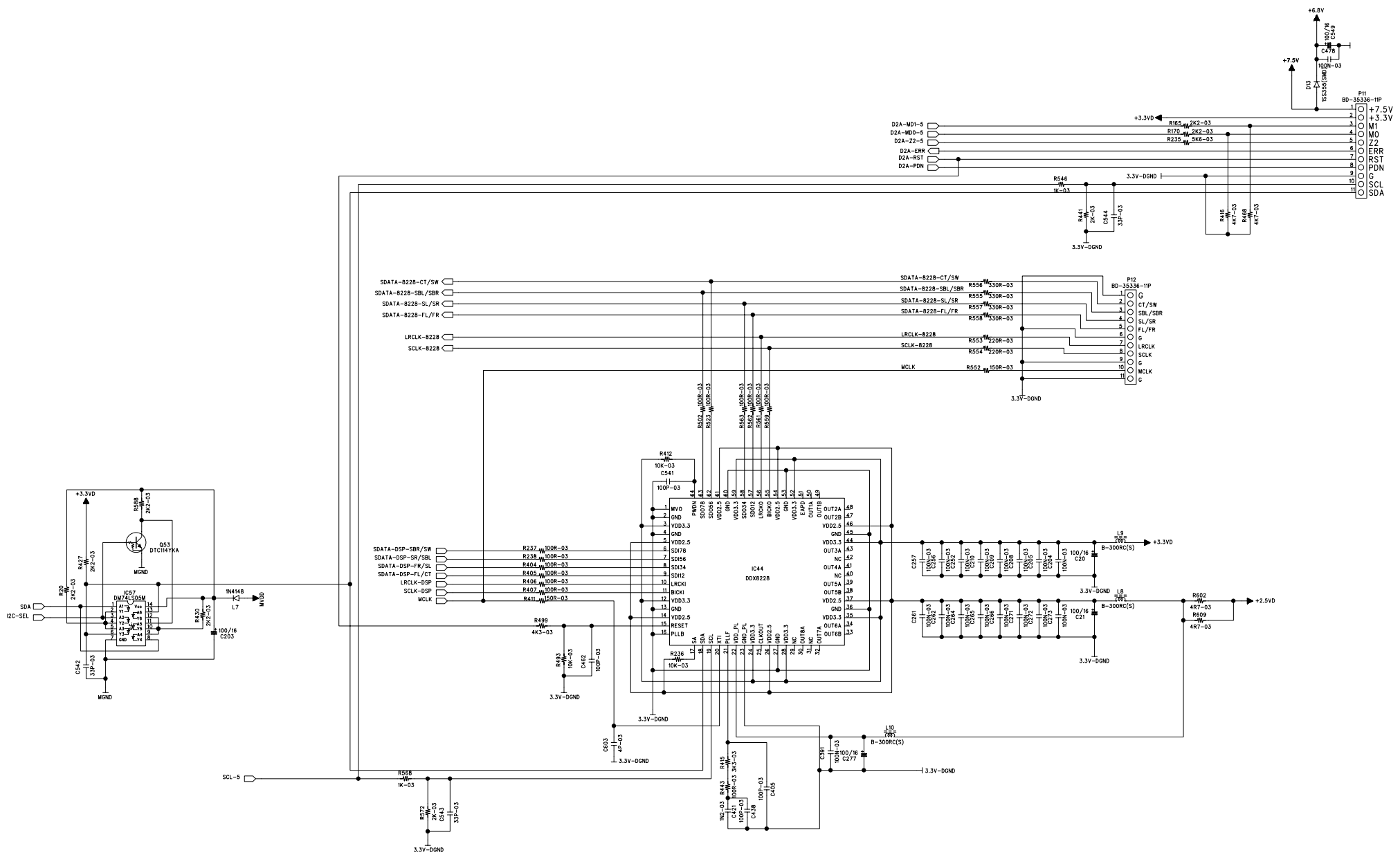

Category	AV RECEIVER	Model	DPR2005/1005
Stage	Ver.	Sheet	B'D name
MP		2/5	PROCESSOR
Draw	Approved	Date	Drawing No
PARK.K.E.		MAR.12.2004	

REVISION RECORD		
No.	Date	Contents

SCHEMATIC DIAGRAM

harman kardon DPR2005/1005 AMP B'D (1/2)

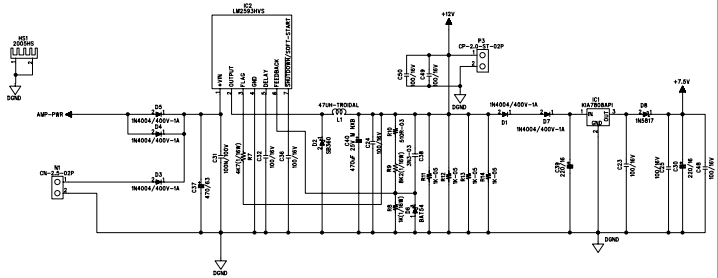
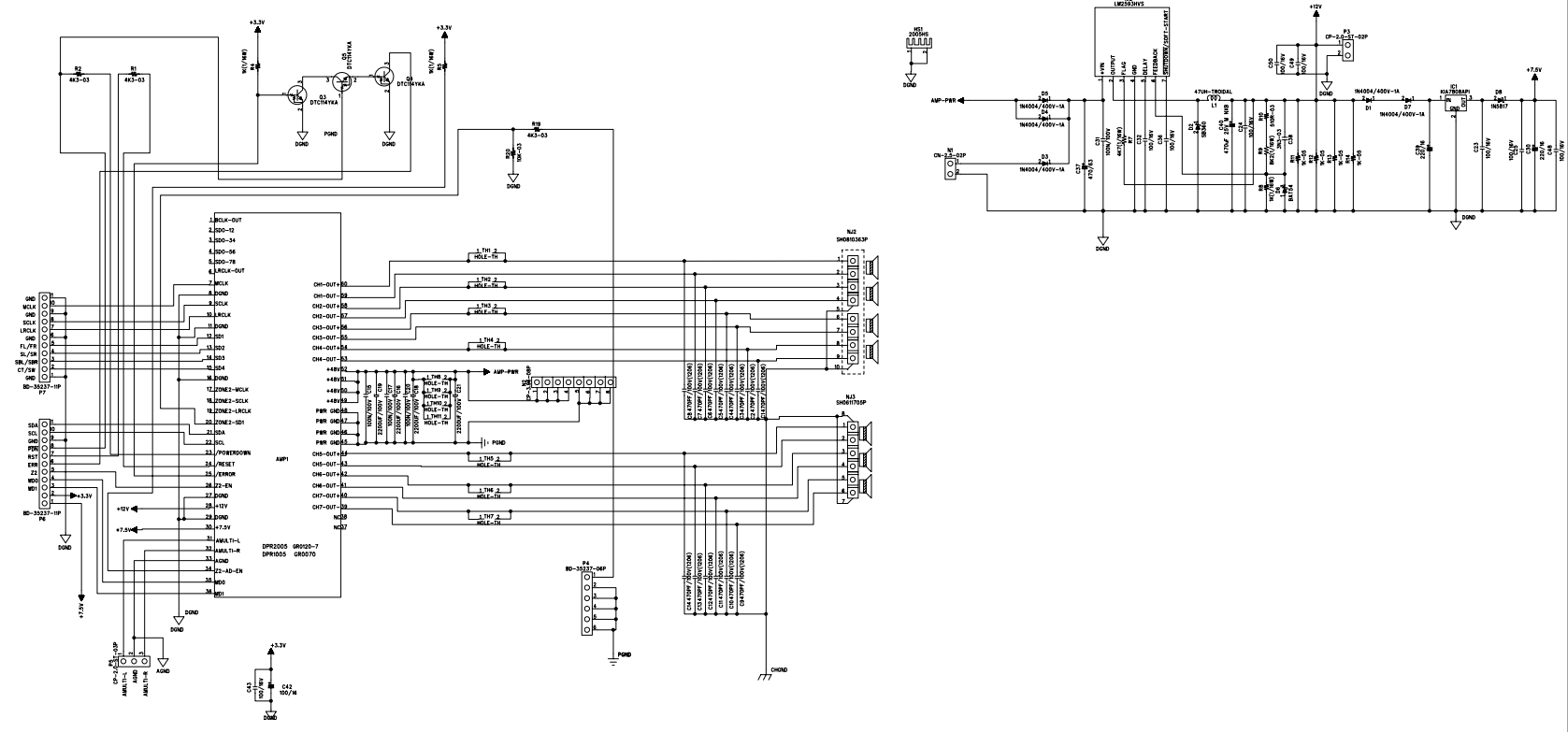

Category	AV RECEIVER	Model	DPR2005/1005
Stage	Ver.	Sheet	B'D name
		1 / 10	AMP
Draw	Approved	Date	Drawing No

REVISION RECORD		
NO.	Date	Contents

SCHEMATIC DIAGRAM

harman kardon DPR2005/1005 AMP B'D (2/2)

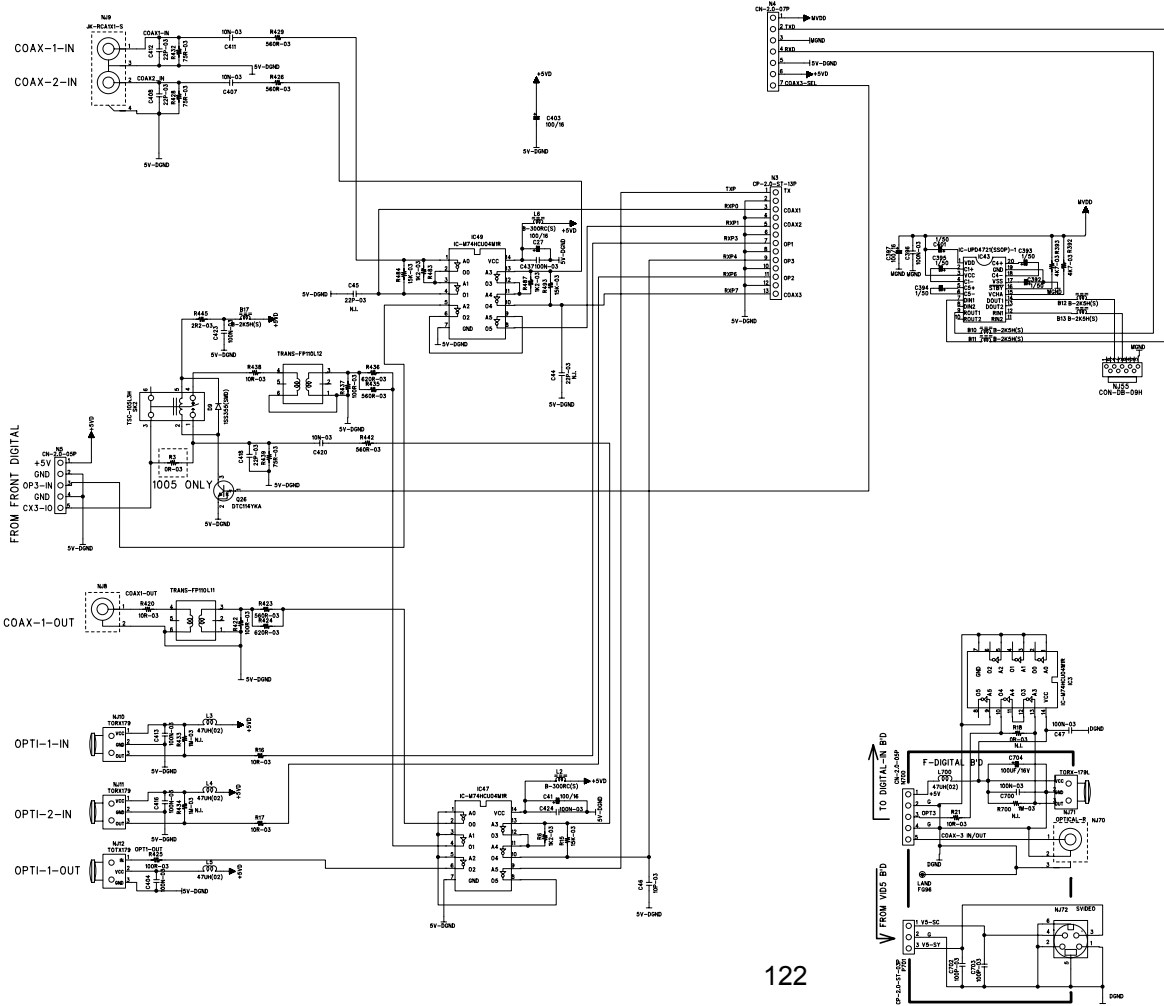

Category	AV RECEIVER	Model	DPR2005/1005
Stage	Ver.	Sheet	B'D name
		2 / 10	AMP
Draw	Approved	Date	Drawing No

SCHEMATIC DIAGRAM

harman/kardon DPR1005/2005 VIDEO B'D

No.	Date	REVISION RECORD

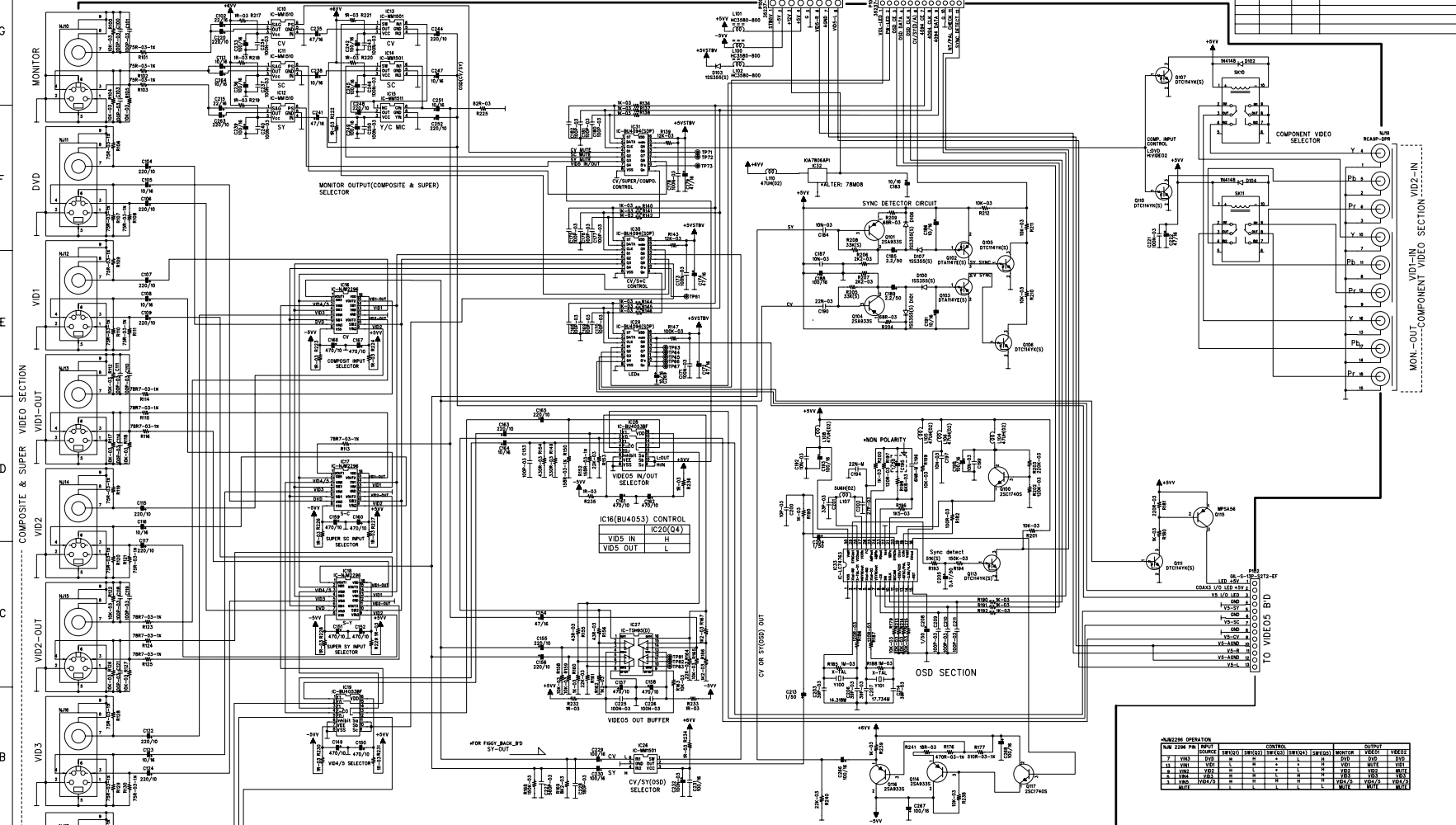

SWITCHING TABLE			+MONITOR OUT OPERATION - OSD FUNCTION									
			OUTPUT			INPUT CONDITION						
IC31(4094) CONTROL	IC30(4094) CONTROL	IC29(4094) CONTROL	CV ONLY DETECT	Q1(C31) SEMI OSD FULL OSD	Q2(C31) ON(H) NON OSD(L)	Q3(C31) OFF(L) ON(H)	Q6(C30) CV(L) ON(H)	Q8(C31) OFF(L) ON(H)	Q7(C30) ON(H) OFF(L)	CV-DETECT	SY-DETECT	FULL OSD
Q1 CV OUT MUTE(NM/SD)	Q1 NJM2296 SW1	Q1 VOLUME LED	SY DETECT	ON(H) FULL OSD	ON(H) NON OSD(L)	ON(H) OFF(L)	ON(H) ON(H)	ON(H) ON(H)	ON(H) OFF(L)	H	L	OFF
Q2 SC OUT (OSD/NON OSD)	Q2 NJM2296 SW2	Q2 POWER LED	NONE SOURCE	ON(H) FULL OSD	ON(H) NON OSD(L)	ON(H) OFF(L)	ON(H) ON(H)	ON(H) ON(H)	ON(H) OFF(L)	H	L	OFF
Q3 SY OUT MUTE(NM/SD)	Q3 NJM2296 SW3	Q3 +5V LED	MUTE	ON(H) FULL OSD	ON(H) NON OSD(L)	ON(H) OFF(L)	ON(H) ON(H)	ON(H) ON(H)	ON(H) OFF(L)	H	L	OFF
Q4 VDS IN/OUT	Q4 NJM2296 SW4	Q4 COAX I/O LED		ON(H) FULL OSD	ON(H) NON OSD(L)	ON(H) OFF(L)	ON(H) ON(H)	ON(H) ON(H)	ON(H) OFF(L)	H	L	OFF
Q5 COMBTV SELECT(NM/PA)	Q5 NJM2296 SW5	Q5 COAX I/O LED		ON(H) FULL OSD	ON(H) NON OSD(L)	ON(H) OFF(L)	ON(H) ON(H)	ON(H) ON(H)	ON(H) OFF(L)	H	L	OFF
Q6 NC	Q6 CV/SY IN SELECT	Q6 NC		ON(H) FULL OSD	ON(H) NON OSD(L)	ON(H) OFF(L)	ON(H) ON(H)	ON(H) ON(H)	ON(H) OFF(L)	H	L	OFF
Q7 NC	Q7 CV/SY+SC SELECT	Q7 NC		ON(H) FULL OSD	ON(H) NON OSD(L)	ON(H) OFF(L)	ON(H) ON(H)	ON(H) ON(H)	ON(H) OFF(L)	H	L	OFF
Q8 SC-OUT MUTE	Q8 VDI4/VDS SELECT	Q8 NC		ON(H) FULL OSD	ON(H) NON OSD(L)	ON(H) OFF(L)	ON(H) ON(H)	ON(H) ON(H)	ON(H) OFF(L)	H	L	OFF

+MONITOR OPERATION										
SW 2296 PA	SW1	SW2	SW3	SW4	SW5	SW6	SW7	SW8	SW9	SW10
V IN	ON	ON	ON	ON	ON	ON	ON	ON	ON	ON
V OUT	ON	ON	ON	ON	ON	ON	ON	ON	ON	ON
VDS	ON	ON	ON	ON	ON	ON	ON	ON	ON	ON
VDS+SC	ON	ON	ON	ON	ON	ON	ON	ON	ON	ON
VDS+SC+MUTE	ON	ON	ON	ON	ON	ON	ON	ON	ON	ON

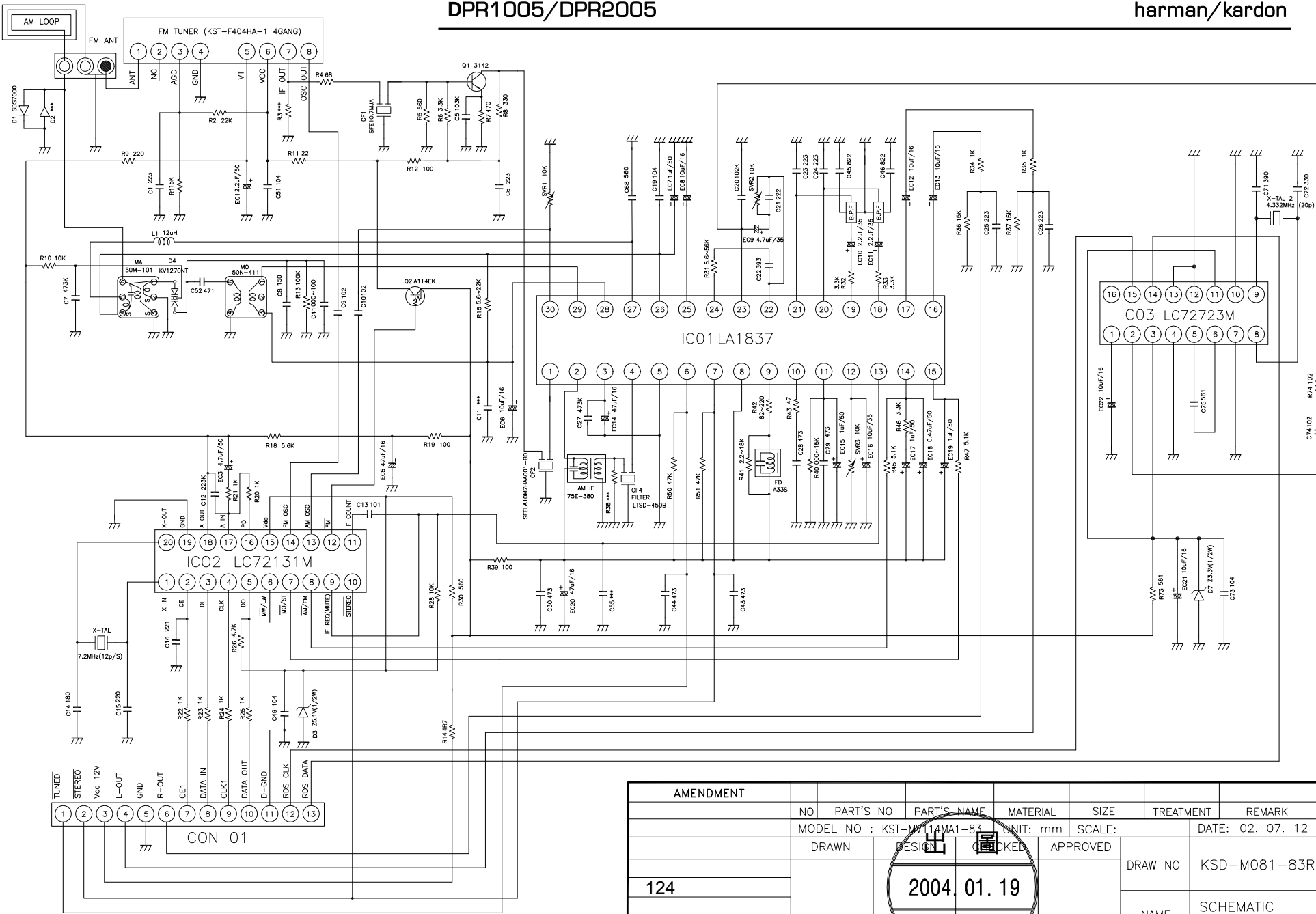

AMENDMENT							
NO	PART'S NO	PART'S NAME	MATERIAL	SIZE	TREATMENT	REMARK	
MODEL NO : KST-M114MA1-83			UNIT: mm	SCALE:	DATE: 02. 07. 12		
DRAWN	DESIGN	CHECK	APPROVED	DRAW NO	KSD-M081-83R		
<div style="border: 2px solid black; border-radius: 50%; width: 100px; height: 100px; display: flex; align-items: center; justify-content: center; margin: 0 auto;"> <div style="text-align: center;"> <p>2004. 01. 19</p> <p>(株)光星電子</p> </div> </div>				NAME	SCHEMATIC DIAGRAM		

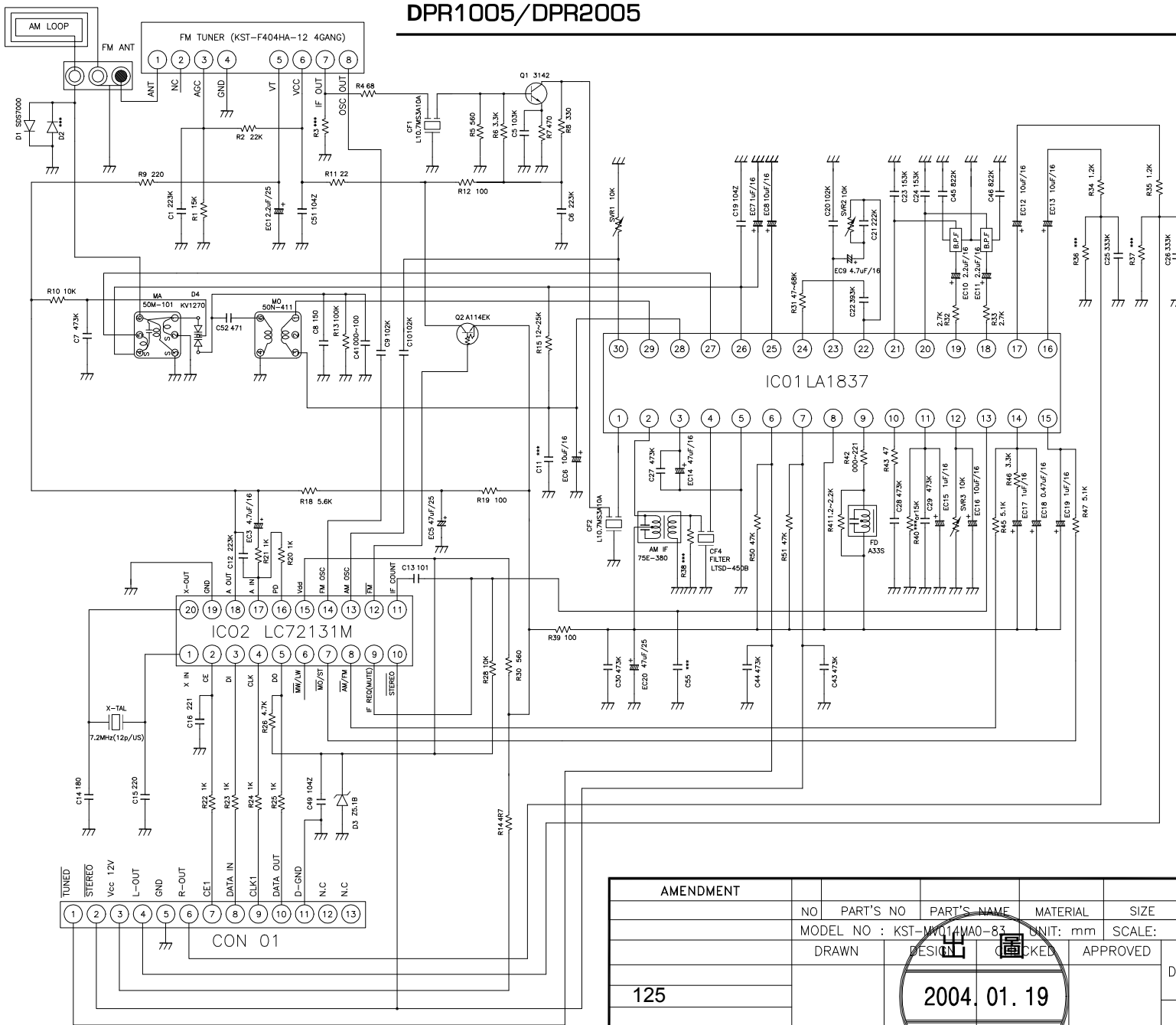

AMENDMENT							
NO	PART'S NO	PART'S NAME	MATERIAL	SIZE	TREATMENT	REMARK	
MODEL NO : KST-MW11MA0-83			UNIT: mm	SCALE:	DATE: 2004.03.13		
DRAWN	DESIGN	CHECKED	APPROVED	DRAW NO		KSD-M081-83	
<div style="border: 2px solid black; border-radius: 50%; width: 100px; height: 100px; display: flex; align-items: center; justify-content: center; margin: 0 auto;"> <div style="text-align: center;"> <p>2004.01.19</p> <p>(株)光星電子</p> <p>技術部</p> </div> </div>				NAME		SCHEMATIC DIAGRAM	

125

harman/kardon DPR1005,2005 WIRING DIAGRAM

REVISION RECORD		
NO.	Date	Contents

G
F
E
D
C
B
A

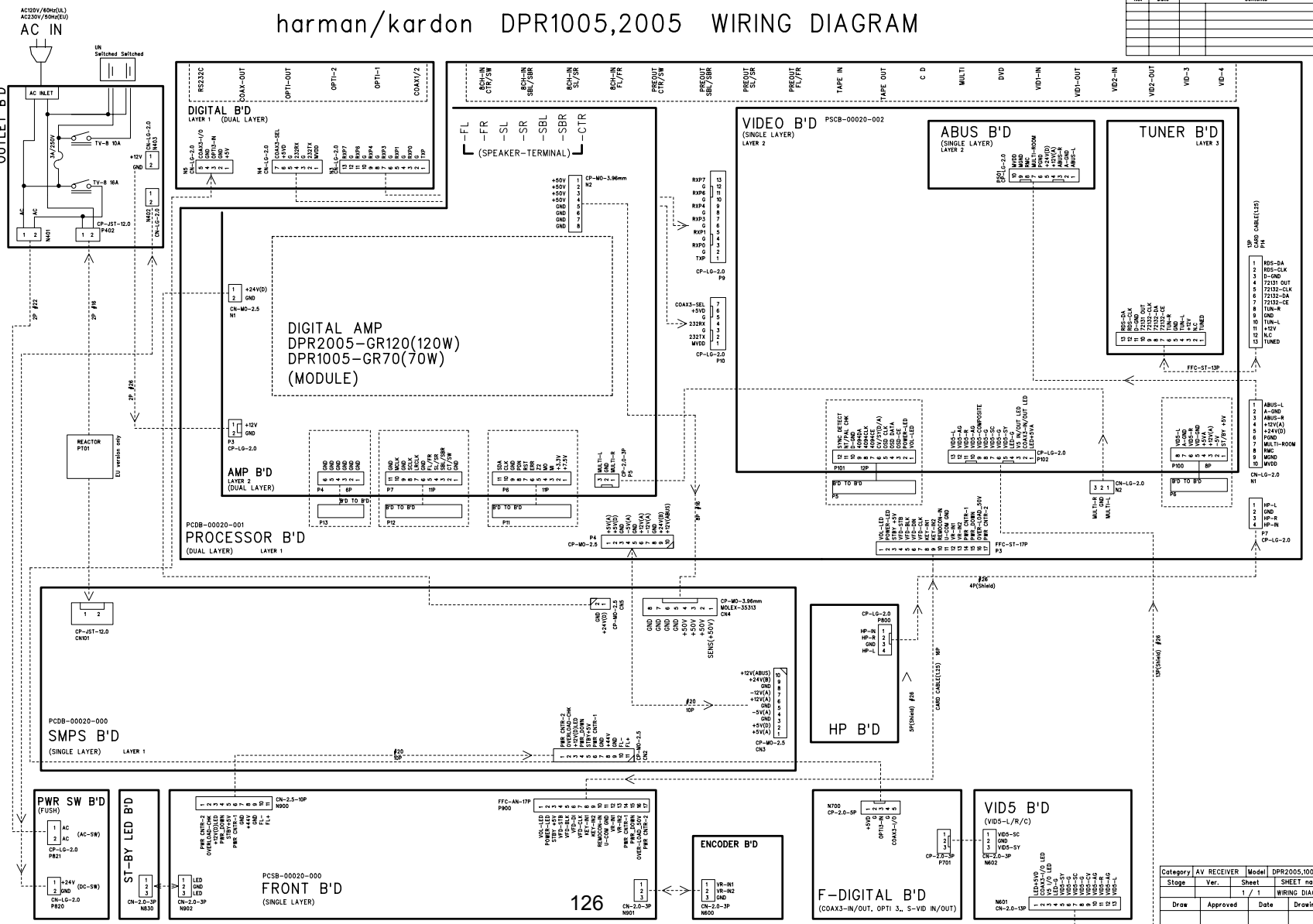

126

Category	AV RECEIVER	Model	DPR2005,1005
Sheet	1	1	1
Draw	Approved	Date	Drawing No

PACKAGE

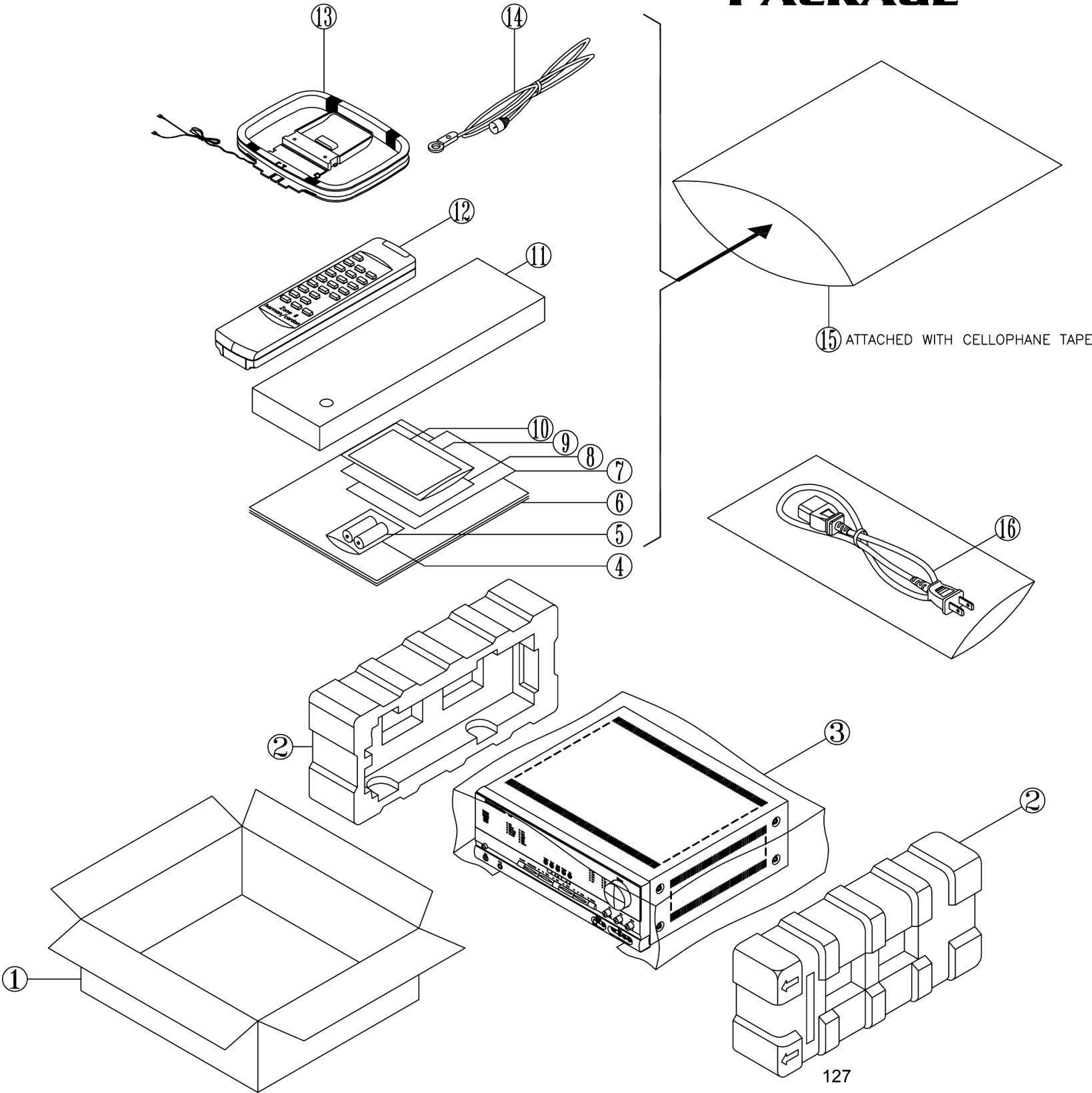

NO.	PARTS NO.	DESCRIPTION	DPR1005 US	DPR1005 EU	DPR2005 US	DPR2005 EU
1	ZKDO304HA00-8	BOX CARTON DPR 1005 US	1			
	ZKDO604HA00	BOX CARTON DPR 1005 EU		1		
	ZKDO404HA00-2	BOX CARTON DPR 2005 US			1	
	ZKDO704HA00	BOX CARTON DPR 2005 EU				1
2	ZQDO301HA00-A	CUSHION POLY EPS	2	2	2	2
3		FILM SHEET PE 920 X 1000	1	1	1	1
4		POLYBAG BATTERY	1	1	1	1
5		BATTERY ALKALINE 1.5V AAA	2	2	2	2
6	ZKDO301HA00-9	USER MANUAL DPR 1005 US	1			
	ZKDO601HA00	USER MANUAL DPR 1005 EU		1		
	ZKDO401HA00-3	USER MANUAL DPR 2005 US			1	
	ZKDO701HA00	USER MANUAL DPR 2005 EU				1
7		QUICK SET UP GUIDE	1	1	1	1
8	ZKC1113HA00-9	CARD WARRANTY	1	1	1	1
9		ENVELOPE POLISHING CLOTH	1	1	1	1
10		POLISHING CLOTH	1	1	1	1
11	BE18A06	ASS'Y REMOCON DPR 1005 US	1			
	H01-RYD0601HA00	ASS'Y REMOCON DPR 1005 EU		1		
	BE18A07	ASS'Y REMOCON DPR 2005 US			1	
	H01-RYD0701HA00	ASS'Y REMOCON DPR 2005 EU				1
12	HG18B00	REMOCON ZONE 2	1	1	1	1
13	H01-ATLLF0146BY-A	ANTENNA LOOP S0146BY-100	1	1	1	1
14	H01-WAB01200203-9	ANTENNA 750hm CT02-FM	1		1	
	H01-WAD01200303	ANTENNA 750hm CT03-FM		1		1
15		BAG PE 330X245 T0.05	1	1	1	1
16	H01-WAUSA2103BK-1	POWER CORD	1		1	
	H01-WAD022000BK	POWER CORD		1		1